

INTERNATIONAL ELECTRONIC MUSIC

January/February 1979

Volume 3, Number 1

\$1.50

Synapse

REVIEWS:

Pere Ubu, Terry Riley, DEVO, Todd Rundgren, Captain Beefheart, Steve Hillage, "Blue" Gene Tyranny, David Behrman, Craig Anderton, Robert Ashley, Meredith Monk.

EQUIPMENT:

Oberheim OB-1, Yamaha CS-80, Arp Avatar.

TECH NOTES:

Controlling & Interfacing Synthesizers. Voltage Controlled Oscillators.

AND MORE!

**BRIAN
ENO**

**FRANK
ZAPPA**

**ALLEN
STRANGE**

**LARRY
FAST**



Sequential Circuits Introduces:

the prophet

The Industry's First Completely Programmable Polyphonic Synthesizer

When Sequential Circuits introduces a synthesizer, you can be sure it utilizes the most advanced technology. state-of-the-art technology that makes readily available the most asked for features musicians have been demanding for years.



the prophet

has 5 complete voices, with 2 oscillators per voice. Individual oscillator tuning? We think you have better things to do with your time. The Prophet's powerful internal computer automatically handles all tuning. The same computer lets you create and record 40 different patches and recall any at the simple touch of a button.

More? A 5-octave keyboard. Pitch and Modulation wheels. Small size (37" x 16" x 4½"), ideal for stacking with other keyboards. Memory power back up with a 10 year life.

The Prophet provides unparalleled ease of use while retaining the sophistication required by the most demanding synthesists.

Prove it to yourself. Ask your local dealer or write us for further information.

SEQUENTIAL CIRCUITS INC

1172G Aster Avenue, Sunnyvale, CA 94086 (408) 296-3116

Editor
Douglas Lynner
Art Director
Chris August
Managing Editor
Melodie Bryant
Contributing Editor
Colin Gardner
Photo Editor
Bill Matthias

Contributing Writers
Greg Allen, Greg Burk, Bob Davis, Richard Diemer, John Parris Frantz, David Fricke, Peter Hillen, Buzz Kettles, Kurt Loder, Kenneth Perrin, White Collar, Dan Wyman

Production Manager
Colin Gardner
Contributing Artists
Curtis Abrue, Tim Alt, Colin Gardner

Contributing Photographers
Ellen Buzzell, Terri Hanlon, Gary Kenton, Eve Kessler

Correspondents
Boston: Kenneth Perrin
Northern California: Phil Loarie
Chicago: John Parris Frantz
Connecticut: Chuck Scribner
Indiana: Marvin Lewis
Louisiana: Tony Prestigiacomo
Maryland: Paul Medlock
Minneapolis: John Borowicz
New York: Carter Thomas
Ohio: David Felder
Oklahoma: Richard Bugg
San Diego: Steve Roach
Texas: Barton McLean
Utah: Rudy Koppl
Australia: Andrew Space
Western Canada: Jerry Ozipko
Colombia: Luis Guillermo Restrepo R
England: K. S. Dulay
West Germany: Christian Charles Kneisel
Japan: Eijii Ueda
New Zealand: Adam Chennels
Sweden: Gregory Allen Fitzpatrick

Cover Illustration
Dana Deranja

Synapse is published bi-monthly at 2829 Hyans Street, Los Angeles, CA 90026 by Synapse Publishing Co. The entire contents of Synapse are copyright © 1979 Synapse Publishing Co., all rights reserved, and may not be reproduced in any manner, either in whole or in part, without the written permission of the publishers. Application to mail at second-class postage rates is pending at Los Angeles. **Manuscripts, photographs & artwork:** All contributions are welcome, however, we cannot be responsible for the return of unsolicited materials. Enclose a self-addressed stamped envelope with any contributions and send to Synapse, 2829 Hyans Street, Los Angeles, CA 90026. **Advertising:** Contact Doug Lynner or Chris August at (213) 383-7933 for our current rate and deadline schedule. **Distributors & Dealers:** Contact Chris August or Doug Lynner at (213) 383-7933 for discount information and publishing schedule. **Subscriptions:** Within the US the annual six-issue rate is \$8.00. A domestic first class mail subscription is available for \$14.00 yearly. The one year foreign subscription rate (by surface mail) is \$10.00. A special foreign air mail subscription is now available for \$20.00 annually. Single copy newsstand price is \$1.50 in the US and Canada; Australia, Europe, and Japan \$2.00. **Back Issues:** We are presently sold out of most issues. Please send a postcard for our files naming the issues you lack and they will be reprinted when demand is sufficient. **Change of address:** Notify Synapse/Subscriptions at 2829 Hyans Street, Los Angeles, California 90026. We are not responsible for issues lost when we have not received an address change notice. Please send both the old and new addresses, and if possible, the mailing label from your copy of Synapse.



Brian Eno

The art of collaboration.
by Kurt Loder 24

Larry Fast

A new Synergy.



with Doug Lynner 28

Frank Zappa

Part two.
by Chris August 31

Composer, performer,
author, educator.

Allen Strange

Interview by Doug Lynner 32

Letters Reader feedback.....	4
What's Happening Around the World.....	6
Profile Omega Intermedia Center, Jasun Martz.....	12, 46
Discola DEVO, Be-Bop Deluxe, The Moody Blues, Lovely Music Series, Steve Hillage, Pere Ubu, Todd Rundgren, Craig Anderton Music Tape, Frank Garvey & New Releases.....	14
Performance Terry Riley, David Behrman, DEVO, Captain Beefheart.....	19
Synthesis First of a new basic synthesizer techniques column.....	36
Tech Notes Controlling and interfacing synthesizers.....	37
Equipment Oberheim OB-1, Yamaha CS-80.....	38
Guitar Synthesis ARP Avatar Guitar Synthesizer.....	40
Computers Computer languages.....	44
Advertising Index	44
Listings Addresses of interest.....	45
Classifieds	45

LETTERS

All Seriousness Aside

In response to John K. Riordan, Letters, Summer '78 issue: I, at least do not want to see any space devoted to "serious" electronic music, or "avant garde" stuff. The value of Synapse is the intense concentration on modern music makers.

Traditional music is nothing short of bankrupt, and the rebirth of serious music lies not with the Cages, Fosses or Xenakis, but the Enos, Froeses, Hoenigs and Baumanns. Any space devoted to the former waters down the value of Synapse, and postpones the inevitable. Additionally, academic music journals devote plenty of space to the academic musicians; anyone interested in that transient art form can look there for coverage of "serious/avant garde" music.

Mark Pearson
New York City

Good music comes to us under many guises. Synapse favors a larger cultural perspective, and it includes all of the people you mention—Ed.

No Imagination

I find the cover print on the Summer '78 issue of Synapse ludicrous, incongruous, and illogical to the thought of your magazine. You destroyed the cover of an excellent issue. I've never heard Devo's music, and judging from their looking like idiots, I'd never want to. I could care less about their interview. I hope I'm not too discriminating.

I would like to praise Ronald Pellegrino on his article of lasers, also in the Summer issue. I can't even imagine the effect of combining synthesized sound waves with laser light. Perhaps the combining of these two stellar sources is not in the too distant future.

Bruce Messier
Jamestown, R.I.

Just a Thought

In the future, is Synapse going to produce articles of a technical nature? What I was thinking of was construction articles. You could have a description of the unit and its performance in the magazine, and then people who were interested could purchase schematics, PCB layouts, and construction plans separately. Just a thought. Perhaps also a readers' idea page, where anyone can send some interesting circuits they've been experimenting with.

Keep up the good work.

Don Miller
West Australia

In the past issues, Synapse has run construction articles for devices such as programmers, V.C. clock with event arranger, and frequency dividers; and we're planning more for future issues. Some of the projects have been made available in kit form by Blacet Musical

Research (address in Listings).

Next issue, Synapse will test a new column reviewing electronic components with many uses in electronic musical instrument design. The first one will be written by Craig Anderton, whose list of credits is too long to list here.

Reader response will decide whether the column will continue—Ed.

New Music for Dance

I read your article on marketing your music in the March issue of Synapse, and noticed that it neglected a ubiquitous art in constant search for original electronic and experimental music: modern dance. Anywhere there is a university, there is most likely a dance department of some sort (granted the exception of technical schools), which means that the students must need music for their choreographies. Judging from my experience with dancers for the past two years, they would much rather have original music, even to the extent of having it performed live!

Eugene X. Rator
DeKalb, IL

DEVO

Thank you for the DEVO interview (Vol 2 No. 6). How do I get a glossy of that fantastic cover photo?

S. Hadley
Toronto, Canada

For information concerning the cover photograph of Synapse Vol. 2, No. 6 write: Bruce Conner, c/o Different Fur Music, 3470 19th St., San Francisco, CA 94110. We're glad you liked it—Ed.

What's the Best Score?

On reading Robert Devo's article on scores for electronic music pieces ("On Keeping Score," Vol 2 No. 6), I had a thought that the ideal electronic music score would be a tape recording of the piece that the composer feels strongly enough about to present to a performer. I have a feeling, unsubstantiated by any sort of research, that the relationship between musical sounds and visual images has been fraught with a great deal of idealism. I know of several projects that have dealt with this subject, and all have so far been unable to come up with any kind of correlation between visuals and music. Perhaps the most successful examples come from film scores, especially recent ones, where the music not only reflects and supports the visuals, but in many cases, anticipates it (*Jaws*). Of course, I suppose it comes down to what the composer wants as a result of a score of a piece

of music, and to what kind of control he/she wishes to maintain over the end product.

The idea of presenting a tape recording of an electronic piece has several advantages (to me, at least). First, it presents the performer with a tremendous technical challenge—imagine trying to perform Varese's *Poeme Electronique*. Second, it allows the composer to pass on to the performer a precise document of the work as conceived, not merely a vague image of a temporal concept. Third, it allows the performer a great deal of expressive freedom in interpretation, since it will be nearly impossible to exactly recreate the piece. The attempt, both musical technical, will show a great deal about the performer's abilities. A tape score, in Devo's words, will, "... express a musical idea and convey the sense of that idea to a musical craftsman who will use it..." Perhaps some of your readers will want to try it to see how it works.

Gerald Lindahl, Director
Public Access Synthesizer Studio
New York City

Electronic Music In Australia

Have just been "patched in" to your magazine, and am delighted at the invigorating information provided.

There have been a number of records produced in the last few years by small companies. One label "Clear Light of Jupiter," has released two albums by an excellent "Tangerine Dream"-style group, Cybotron. The first was self-titled, and the second, recently released, *Colossus*.

Another interesting album is *Jive to Stay Alive*, produced in 1976 by Dennis Garcia. It utilizes biofeedback as the primary source for signal generation. Dennis soon will be completing recording for his second album, then will be touring Australia with two companions, in which the three of them will be linked to a minicomputer and synthesizers.

Andrew Space
Victoria, Australia

Thanks, Andrew—Ed.

Does Digital Spell Doom?

After reading your article on Cameron Jones, a few thoughts have come to mind.

The digital synthesizer, as a small computer, is indeed opening a whole new world of sound to us. But does digital spell doom for the analog synthesizer? Is the latter now to be thought of as outdated? Maybe an article that focuses in depth on comparisons of

analog and digital synthesizers would aid those who are contemplating a major purchase.

Is digital a fad, or are all the analogs going to be let out to pasture someday?

Lawrence Joseph Gagliano
Saint Petersburg, FL

The range of serious interest in musical applications of digital technology would indicate that it is not a fad, but it is also in its very early stages. Analog systems are also advancing at a high rate, and are more than competitive with their digital counterparts. The designers with the most experience in dealing with musical instruments are the analog designers. This experience will never become outdated—Ed.

Real Quark!

Thanks to Andy Capraro for his review of Hawkwind's *Quark, Strangeness and Charm*. Many people, especially the so-called professional music reviewers of other magazines, would've already had this group's review written before they had even listened to the album. That is, if they would ever take the time to review such an un-pop-ular group in the first place. I'm glad to see somebody had the guts to give this deserving group a chance.

Hawkwind is light years away from the contemporary rock scene. Maybe our great grandchildren will finally recognize their genius, and delegate them a higher position than is afforded them today. Hawkwind's growth and continual exploration is reflected in each album (of which there are ten, soon to be eleven). Each album has its own mood, its own flavoring, and Hawkwind does not settle into a groove and stagnate as many bands do. And, contrary to what must be popular belief, Hawkwind is not an LSD band. I've got all their albums, and the only thing I'm addicted to is their music.

Tom Buzzetta
Florissant, MO

Crib Notes: Balls Sales Soaring

I would like to thank you for featuring our Model CR-666 Crib and Sliding Gate Assembly on your excellent Devo cover (Synapse Summer '78). Since that issue hit the stands, Crib-O-Plegix sales have skyrocketed by 6%, and crib ball accessory kits are back ordered for four years! Our technicians have nearly completed development on a retrofit kit for all cribs that will allow voltage control of the side gates (power supply included).

Hope you enjoy the Mattress Assembly Kit enclosed. It's pressure sensitive!

Babe E. Bed, Pres.
Crib-O-Plegix Group, Inc.
Box Springs, Colorado

TALKING MUSIC



The **KORG** VC-10 turns words into music.

The Korg VC-10 makes any electronic sound source (musical instruments, tape recorders, etc.) appear to talk. The VC-10 "encodes" your speech signal (singing or just talking) and controls the tones of the musical source, so they become "words within music."

Vocoder effects can be very spacey. And so can their prices. But Korg's new VC-10 puts "vocoding" within the reach of all musicians.

Hear the VC-10 at your nearest Korg dealer. And the next time you're recording or performing, "say it with music." Literally.



WHAT'S HAPPENING

....Noted columnist and musical self-sufficiency advocate **Craig Anderton** has designed the **Organtua**, recently released by **PAIA Electronics, Inc.** The Organtua is a three rank organ kit with each of the three ranks independently detunable for chorusing effects. The kit is shipped collect for \$279.95. PAIA 1020 W. Wilshire Blvd., Oklahoma City, OK 73116.....

....**Serge Modular Music Systems** has announced the **Touch Activated Keyboard Sequencer (TKB)**. The TKB features a sequencer that is sixteen steps long and four rows deep. The sequencer can run forwards, backwards, and in a random fashion. The row or bank can be changed independently, yielding up to a 64-stage sequence. The touch keyboard can be used for its own voltage and trigger outputs as well as to control the sequencer in real time. Each key can represent a preset bank with an array of four voltage outputs (not counting the key voltage), or control sequencer length and stage access. The unit is available for \$550.00 in kit form and \$750.00 assembled. Also new from SMMS are the **Wave Multipliers (VCM)**. The VCM consists of three independent patchable sections. Multiplier one will square signal inputs when set in the high position and act as a linear gain control VCA in the low setting. Multiplier two produces a voltage controllable sweep of the odd harmonics when a triangle wave is introduced to its input. Audio signals can be used to voltage control the multiplier allowing unusual types of modulation. The third multiplier performs full-wave rectification allowing sweeps of the even harmonics. There are two modulation inputs. The module is available from Serge Modular Music, 1107½ N. Western Ave., Hollywood, CA 90029, for \$210.00 assembled, and \$160.00 in kit form.....

....**A/DA**, 2316 Fourth Street, Berkeley, CA 94710 have marketed the **Harmony Synthesizer**, a device using analog delay lines to shift the pitch of the



PAIA's Organtua, designed by Craig Anderton. Gorilla suit optional.

....**IRCAM** has released a catalogue of scientific reports pertaining to its current and recent research. Many of the reports are in English and cover topics ranging from real time synthesizer control to musical acoustics. For full descriptions and prices, write: IRCAM-Relations Exterieures, 31 rue Saint-Merri, F-75004 Paris.....

....The **University of California, Berkeley** will be offering an electronic music course to be taught by **Paul Kalbach** in his studio. The course will be, "A practical hands-on equipment and theory course in electronic music and Musique Concrète. Students will learn tape manipulation techniques as well as use of the synthesizer, so that they may create electronic music without the use of expensive, sophisticated equipment." For information, call (415) 655-1283.....

....The **United States Committee for UNICEF** and **IYC** (International Year of the Child) have appointed **Kansas** (the group) Deputy Ambassadors of Good Will for UNICEF. Kansas donated a large portion of the proceeds from its sold out Madison Square Garden concert to the

Childrens' Fund of the United Nations..

....Congratulations to Synapse correspondent **Carter Thomas** and his wife **Connie** on the birth of **Jeremy Norman Thomas**, May 26, 1978. Rumor has it that Jeremy has devised an unique system for controlling synthesizers with baby rattles and mobiles. The device is velocity sensitive as well as responsive to moisture. What will they come out with next?.....

....**MR Engineering** company has released a line of inexpensive and useful products. **The Switcher** is a foot pedal operated AB switch. One input can be switched to either of two outputs, or two inputs can be selected for the output. List is \$65.00. **The System 6** is a six input keyboard mixer listing for \$170.00. **The Patcher** is a multibox with three arrays of mini-jacks. It lists for \$40.00. MR Engineering Co. 4730 W. Addison, Chicago, IL 60641.....

....**Strider Systems** recently released the **MicroSequencer** listing for \$569.00. It is a 63-note monophonic sequencer with a 7-octave control voltage range and a playback tempo range

of 6 beats per minute to 24 beats per second. Various controls allow for manipulation of the sequence during playback and record. Strider Systems, P.O. Box 2934, Norman, OK 73070.....

....The **1978 International Computer Music Conference** will be held at the **Northwestern University School of Music**, November 1-5, 1978. Major topic areas for papers include software synthesis techniques, synthesizer hardware, digital recording, interactive music systems, acoustics, psychoacoustics, and studio reports. Registration is \$25.00 before October and \$30.00 thereafter. Students are charged \$10.00. For information on attending and/or presenting papers, contact Peter Gena and Gary Kendall, School of Music, Northwestern University, Evanston, Ill. 60201.....

....New from **Wavemakers** is the **858 Series Mixing Systems**. Featured are four main output assign switches with L/R manual pan control as well as three process busses with individual send-level controls and a switched solo bus. Each channel is also terminated before and after E.Q. on the rear panel. Three effect returns are independently switchable to any of the output channels and can be used to mix line level inputs into the final output. Also featured are voltage controllable input channel gain, and 3-band E.Q. per channel (7-band output channel E.Q. optional). Optional subsystems include the 477 output system which includes expansion and limiting for noise reduction of inputs, 5 step LED peak indicators for each channel, a joystick and master output remote control. The system can be packaged to have input gain control at slave stations for each performer as well as timbre and placement. Contact Wavemakers, P.O. Box 27, Edmonds, WA 98020.....

....**MXR Innovations, Inc.**, 247 N. Goodman Street, Rochester, NY 14607, have released the **Dual Fifteen Band Equalizer**, and the **Thirty-One Band Equalizer**. The former is a two channel system with each band spaced at 2/3 octave intervals and ± 12 db range per band. The latter has 31 bands spaced at 1/3 octave intervals. Each unit features an in/out switch for activating the equalizers.....

....**PPG, Inc.** of Hamburg, West Germany has gained a certain amount of notoriety in the U.S. because of the use of their synthesizers by groups such as **Tangerine Dream**. Some of the following information was translated from German and a chance for error exists although great care was taken to insure accuracy. An interesting two-voice synthesizer is the **Sonic Carrier**. Aside from a few sliders and pots on the keyboard section, the system has push buttons that engage and attenuate the various ins and outs of the modules. As the system is partially digital, new twists to common synthesizer terms are encountered such as DCO, or, Digitally



The A/DA Harmony Synthesizer shifts the pitch of single lines and chords.

input up one octave or down two. Delay of up to 200 milliseconds is available. The unit will shift chords as well as single lines and lists for \$499.95.....

FINALLY.



You're a keyboard player, and a good one. That's why you deserve a synthesizer that gives you control. One that responds to your hands, and the technique you've perfected. An instrument that allows and encourages creativity, and lets you play *music*. In short, the all-new Yamaha CS-80 Polyphonic Synthesizer.

The CS-80 is velocity sensitive and pressure sensitive. The volume and brightness, as well as the character of the sound is in your hands.

You have control not only over the notes you play, but also the 22 internal preprogrammed voices, including Strings, Brass, Clavichord, Organ, Electric Piano, Electric Bass and Guitar. The voicings and settings are

A SYNTHESIZER THAT PLAYS AS GOOD AS YOU DO.

easy. But your creativity is never compromised: adjust envelope characteristics, filters and equalization, vibrato, pitch and touch response so that you get your taste, not somebody else's.



YAMAHA

P.O. Box 6600, Buena Park, CA 90622

Four memory banks let you summon the voices *you've* created and preprogrammed.

Because the CS-80 is a polyphonic synthesizer, eight notes can be played simultaneously, generated by 16 oscillators. And with two channels you get the added flexibility of producing two different voices in any mix you want.

You'd expect a one-of-a-kind synthesizer to come from the people who've been perfecting musical instruments for nearly a century. Write for a free brochure. Or try a first: play *music* on a polyphonic synthesizer. The CS-80. Or try the CS-60, or the CS-50. They're all polyphonic, and they're all at your Yamaha dealer.

SYNAPSE
subscribe!



ORIGINAL ART WORK BY JEAN-FRANCOIS PODEVIN

In the US: One year/six issues: \$8.00. Two years/twelve issues: \$14.00. **Outside the US:** One year/six issues by surface mail: \$10.00. Two years/twelve issues by surface mail: \$18.00. One year/six issues by air mail: \$20.00. **For the current issue of Synapse only:** Send \$1.50 plus 75 cents for first class postage and handling. All orders must be prepaid in US funds. Send all orders to: Synapse Subscription Department 3:1, 1052 West Sixth Street, Suite 424, Los Angeles, California, 90017. **Back Issues:** See coupon for complete details on available issues.

SPECIAL POSTER OFFER: For a full size (17X22 inch) version of this poster, send \$4.00 (plus \$1.00 post & handling within the US, \$2.00 outside the US) to: Synapse Poster, 1052 West Sixth Street, Suite 424, Los Angeles, CA 90017. All orders must be prepaid in US funds. Allow 4 to 6 weeks for delivery.

Controlled Oscillator. Using a programmable memory unit, patches can be stored and recalled in performance. The two DCOs are assigned a frequency by pressing the fixed frequency button on the DCOs and the desired key on the keyboard. That pitch, a "G" for instance, is then the pitch of the lowest "C" of the keyboard, thereby setting range and demanding little of a musician's knowledge of key signatures. Triangle, saw and variable pulse width waves are available from DCO A and it can be modulated by DCO B. DCO B has synch, no modulation inputs, and variable pulse wave, square wave and sawtooth. All of the wave form outputs on both oscillators are attenuated in steps by pushing the appropriate button. The Digitally Controlled Filter has its center frequency set by a button quantized into eight steps per octave over eight octaves. ADSR and AR envelope generators are included along with a DCA (you guessed it.) featuring a treble booster. Write PPG, Ing. W. Palm, Landwehr 11, D-2000 Hamburg, West Germany.....

....**Computer Mart Systems**, 13 East 30th St., New York, NY 10016 is offering the **PME-1 Memory Board** in three configurations designed to add 16, 24, or 32 kilobytes of memory to the **Commodore PET** computer. They cost \$500.00, \$595.00 and \$675.00 respectively and come complete with hardware.....

....**360 Systems** has released the **Spectre** guitar synthesizer, listing for \$1695.00. The system is packaged in a road case and has 2 VCOs, 2 envelope generators, a four mode VCF, 2 preset-



360 Systems Spectre.

able interval transposers, hex-fuzz, string select switches, and an input for straight guitar into the filter for processing of chords. The hex pickup is included as well as an interface jack for the Sequential Circuits Programmer. 360 Systems, 18730 Oxnard St., No. 215, Tarzana, CA 91356.....

....A novel security device, **The Pro-tekter**, is being offered by **Suburban Electronics**, 1250 West Dorothy Lane, Dayton, OH 45409. The unit senses motion and produces a siren when any is sensed. It can be secured to equipment to protect while in storage, or while waiting in transit. The sensitivity of the motion detector is adjustable.....

....Five new studio products have been released by **RolandCorp U.S.**, marketed under the name **Roland Studio**

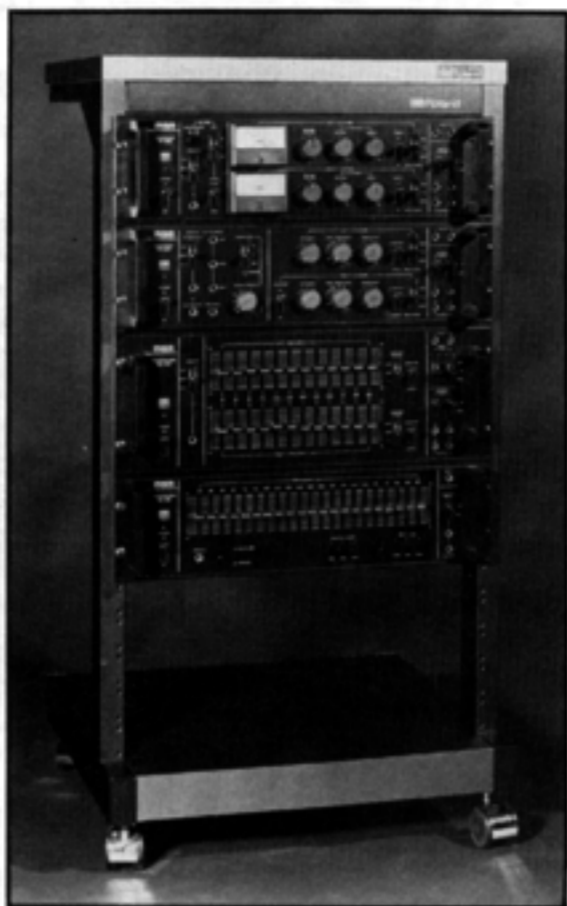

Roland Studio System.

System. The system is packaged in a 19-inch EIA-3U rack and each product is also available separately. The **RV-800** stereo reverb retails for \$795.00, the **GE-810** monaural graphic equalizer, \$650.00, the **GE-820** stereo graphic equalizer, \$775.00, the **PH-830** stereo phaser, \$725.00, and the **PW-250** and **500** power amplifiers have no price set as of yet. RolandCorp U.S. 2401 Saybrook Ave., L.A., CA 90040.....

....New from **Pyramid Electronics Products**, P.O. Box 6171, San Rafael, CA 94903, is the **Universal Hot Box**. Listing for \$166.00, the device is used to connect electric and electronic instruments directly to a recording console. Manufacturer's literature lists instrument direct box, amplifier direct box, octave splitter, pre-amp or overdrive, effects driver, headphone amplifier, unbalanced to balanced line converter, and sound-on-sound recording, or practice mixer as uses of the product.....

....New from **Octave Electronics** is the **Cat Stick** synthesizer controller. The X Y axis joystick is divided into four independent output sections, each with its own VCA and voltage. Two LFOs and an internal noise source can be gated through each VCA and controlled by the joystick position. The stick is spring loaded and returns to zero. Octave Electronics, 32-73 Steinway Street, Long Island City, NY 11103..

....The **Department of Music** of the **State University of New York at Stony Brook** has initiated a Ph.D. program in instrumental and electronic music. Facilities include a recording studio, a suite of electronic music studios engaging classical, synthesizer, and digital systems techniques. A Buchla analog/digital hybrid system is to be installed in November 1978.....

....**Gentle Electric**, 140 Oxford Way, Santa Cruz, CA 95060, has announced their **Model 101 Pitch and Envelope Follower**. The \$549.00 unit features a low noise mic. pre-amp for low or high

serge modular

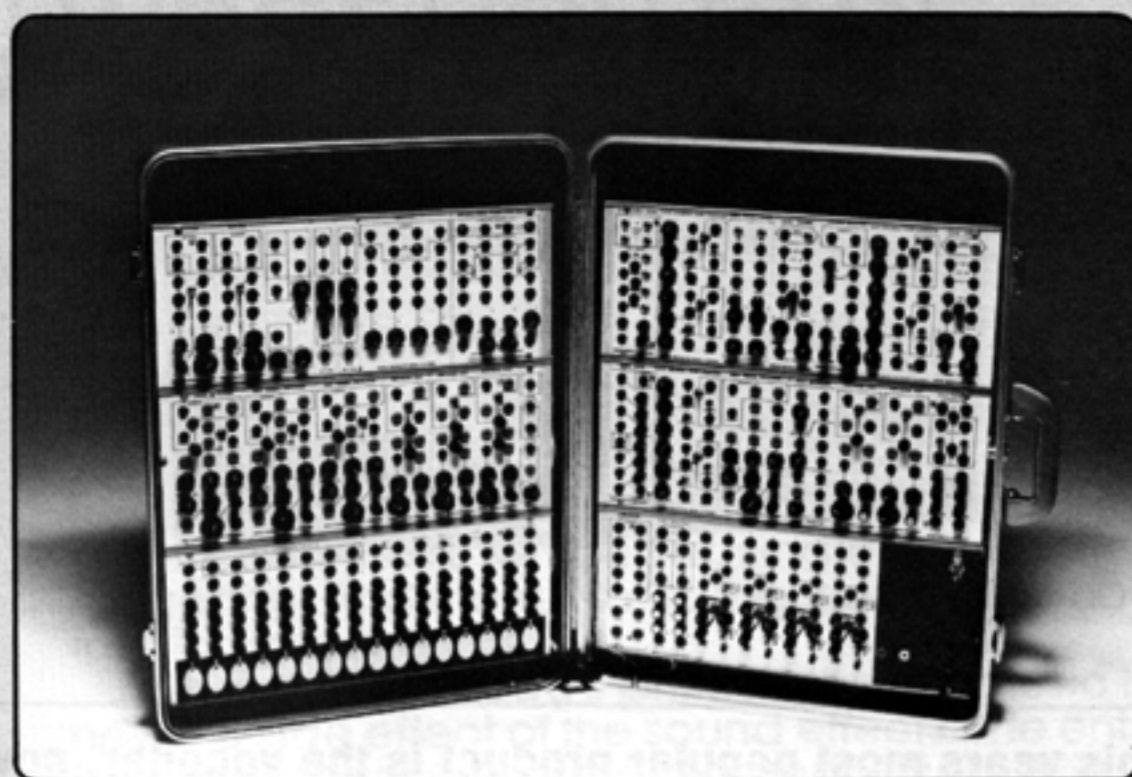

PHOTO BY BILL MATTHIAS

music systems



We'd like you to know about Serge Modular. We make what may be the most precise and versatile synthesizer system in use today. The Serge Modular is available either fully assembled or in money saving kit form. We made it modular, to assure that a musician (or video or computer artist, for that matter) can put modules together to fit his or her specific needs, and also to make room for future expansion of a Serge System. We adhere to industry standards such as 1 Volt per Octave VC inputs etc. to allow easy interface between Serge Systems and other synthesizers. We made it as versatile as we could within the state of the art, because we wanted to expand the possibilities of synthesis, not to limit our equipment to a few pre-patched effects. We made it innovative, because our pursuit of the highest quality allied to an affordable price made it hard not to be innovative, and because we are basically research rather than commercially oriented.

A few specifics about our hardware: We make the stablest oscillators, guaranteed over a temperature range of 40 to 100°F. And the trackingest. Our precision VCOs track within a cycle over the entire pitch range. Our VCAs and Panners feature over 80 dbS/N and better than 60 dbS control rejection. Whether stereo, quad, penta or octophonic, our panners adhere to the equal power law for the smoothest

and most accurate spatial location. Many of our modules are patch-programmable. This means that they can be patched to perform functions which in traditional systems would require separate costly modules. For example, our Dual Universal Slope Generator can be patched to work as envelope followers, log-linear saw, triangle and timing-pulse VCOs or LFOs, accurate VC portamento, VC pulse delays, envelope generators, and VC sub-harmonic generators. We use industrial quality components only, to ensure 100% reliable performance. **When we ship an assembled system, it is fully burned in, calibrated and guaranteed 2 years, parts and labor.** When we ship a kit, even an inexperienced kit builder is assured success, because we ship all pc boards fully assembled, tested and calibrated.

We wish we could tell you more about **Serge Modular**. Being innovative, and not necessarily falling under run of the mill categories, our modules may cause some consternation. Wherever possible, we'll gladly arrange a live demonstration in your neighborhood. (We find our customers are our best sales people.) If that's not possible, we'll gladly answer your questions by return mail. Meanwhile, you may wish to order a packet of information concerning Serge Modular, consisting of a variety of new product announcements, our catalog & price list, and a short Instruction Manual. All that we ask of you is to send us \$2.00 for the packet, and your name and address to:

Serge Modular Music Systems

1107-1/2 N. Western Avenue
Hollywood, CA. 90029
(213) 461-7987

WHAT'S HAPPENING

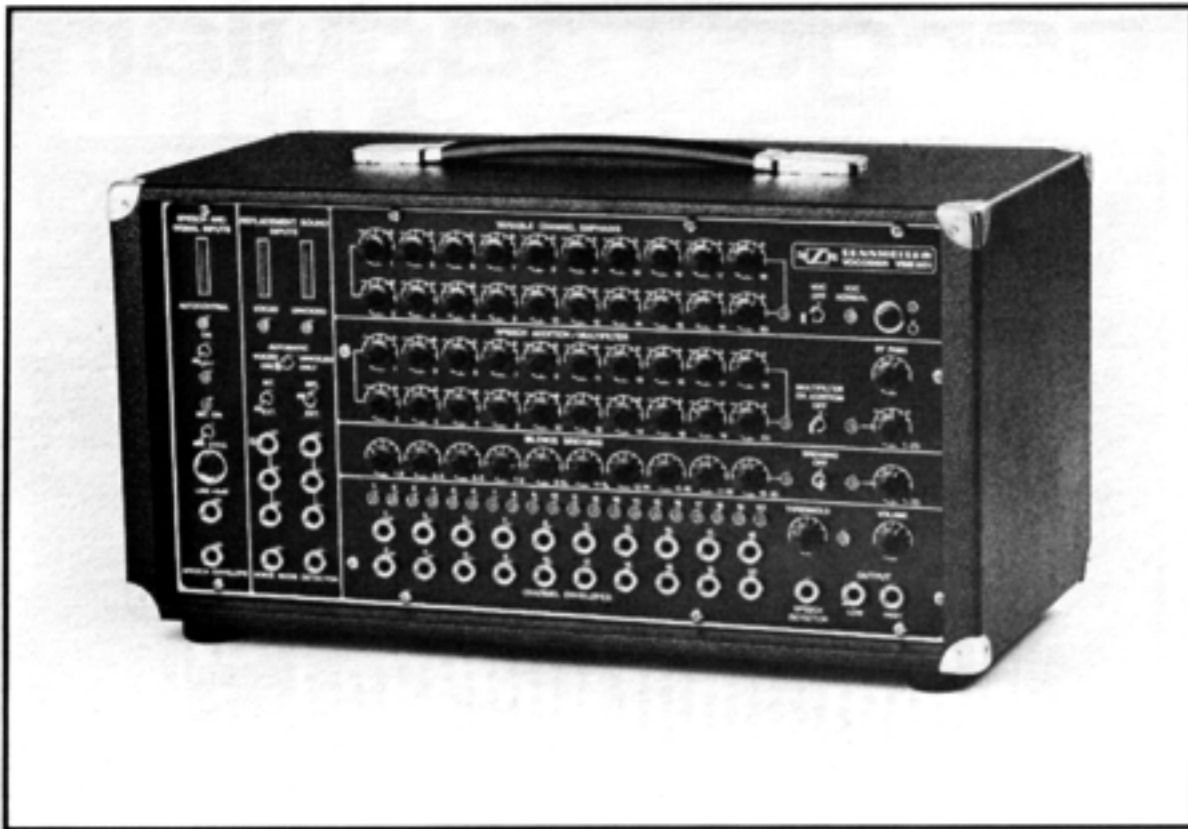

This year's most popular product is the vocoder, now manufactured by Electro-Harmonix, EMS, Korg, Moog, and Sennheiser. Pictured above, Korg's VC-10 (right) and Sennheiser's VSM 201 (left).



PHOTO: BILL MATTHIAS

impedance signals as well as a compressor. The 1-volt-per-octave pitch control voltage output is listed as having a range from 30Hz to 10KHz. Other outputs include a fundamental frequency pulse wave, linear and logarithmic envelope followers, and a variable sensitivity gate and trigger. A pitch sustain footswitch and a Moog trigger adaptor are offered as accessories.....

....**New England Video**, P.O. Box 34, Newton, MA 02159, has moved into a new market with the release of their "All About Electronic Music" videotape series. The series is conducted by **Robert Ceely**, director of **BEEP Electronic Music Studio** in the Boston area. The first tape is an overview of electronic music including discussions of voltage control, envelope generation, filtering and mixing. Other tapes cover specific instruments including the **EML**, **Moog**, **Star Instruments**, **Polyfusion**, **Buchla** and **ARP** brands, as well as concepts in composition and the use of tape recorders. Most tapes are \$49.95 each, and a lesson manual is included.....

....**Korg** has released the **VC-10 Vocoder**, with a retail price of \$1199.00. The unit has a 32-note, top octave divided keyboard, with pitch bend and chorus effects. Using an external input or the internal tone generators, the vocal character of your voice through a microphone will shape the sound source. Korg has also released the **MS-10 Synthesizer** (List \$399.95) featuring one VCO with four wave forms, a VCF that oscillates, ADSR, programmable control wheel, mixable VCO and VCF modulation controls, and patching; the **MS-20 Synthesizer** (\$650.00) with dual VCOs, VCFs, and envelope generators, as well as an LFO with continuously variable wave forms and sample and hold. Also featured is an External Signal Processor with a pre-

amp, variable band pass filter, envelope follower, trigger detector, and pitch follower. Patch points are also provided. The **SQ-10 Analog Sequencer** (\$499.95) is a 12-note sequencer with three independent rows. Featured are portamento effects for rows A and B and a variable width trigger output. Korg/Unicord, 75 Frost St., Westbury, N.Y. 11590.....

....**The Synthesists Workshop** is now offering a course on basic synthesis, keyboard performance, musical acoustics, recording techniques and live performance aspects of synthesis. Instruments used will include an **ARP 2600**, **Oberheim**, **EMS** and **Stramp** synthesizers. The course will be in three hour sessions held three times a week for four weeks, at a cost of \$225.00. Private instruction is also available. For further details, contact Douglas Masla at the Synthesists Workshop, 551 Wilmot Road, New Rochelle, N.Y. 10804....

....**Interval** is a microtonal newsletter published four times a year. It contains articles on instrument building, microtonal mathematics, book and performance reviews, as well as interviews and profiles on people involved in microtonal music. Subscriptions are \$8.00 for one year. Send inquiries to Interval, P.O. Box 8027, San Diego, CA 92102.....

....**Lingua Press** announces **Collection 2**. The collection consists of 38 works by experimental composers, writers and artists in the form of printed music, books, articles, film, tapes and recordings. Also available is the previously published **Collection 1**, containing 40 works by **Kenneth Gaburo** as they were conceived in score, article, tape and video form. For information, write to Lingua Press, P.O. Box 1192, La Jolla, CA 92038.....

....Readers in New Zealand, Australia, Taiwan, Japan and the Hawaiian Islands will have an opportunity to see the **Electric Weasel Ensemble** during

the group's planned Pacific tour—Summer 1979. The ensemble will consist of **Allen Strange**, **Patricia Strange**, **Steven Ruppenthal** and **David Morse**. For information contact the Electric Weasel Ensemble, 4 Euclid Ave., Los Gatos, CA 95130 (408) 354-1591.....

....A new wireless guitar line is being marketed by **HM Electronics** 6151 Fairmount Ave., San Diego, CA 92120. The **Cordless I** system lists for \$1295.00 and has a frequency response of 20Hz—15 kHz, ± 2 db with an operating range of 1000 feet line of sight. The **Cordless II** (\$399.95) has a frequency response of 20Hz—7 kHz with an operating range of 50 feet. The company also markets a full line of wireless communications systems.....

....**Roctronics Entertainment Lighting Inc.**, 22 Wendell St., Cambridge, MA 02138, have released the **Patch Box**. The \$200.00 device accepts 6 inputs and provides 12 outputs to control various lighting systems from one console.....

....The **Sennheiser VSM 201 Vocoder** is now available for rent in Southern California. **Rolls Electronic Corporation**, 4260 Lankershim Blvd., N. Hollywood, CA 91602, is making the unit available for \$460.00 per day including the services of an "independent Vocoder specialist.".....

....**Moog** has released two new keyboard synthesizers. The **Polymoog Keyboard**, list \$4895.00, has 14 preset voices including strings, piano, organ, and brass. The **Multimoog** features two VCOs, LFO, fully variable wave shaping, single and multiple triggers, and the standard Moog Keyboard controls. The keyboard will also control other synthesizer functions such as vibrato, trills, and sample and hold by pressing onto the key after initial contact for pitch voltage and trigger

have been made. The unit lists for \$1495.00. For more information write Norlin Music, 7373 North Cicero Ave., Lincolnwood, Ill. 60646.....

....The **University of Sound Arts** is now offering instruction on the operation of a record company. Taught by industry professionals, students will learn all phases of company activity from talent scouting, recording and engineering, to marketing of product. The program will begin in September, 1978 and class size will be limited. For information write Manny Freiser, University of Sound Arts, 1508 Crossroads of the World, Hollywood, CA 90028

....**Nasty Cordless**, P.O. Box 2205, Berkeley, CA 94702 now manufactures a cordless microphone system. Consisting of a transmitter (\$600.00) and receiver (\$600.00), the system can be used with any professional microphone....

....**Mediamix** introduces the **Programmable LFO**. The PLFO consists of a voltage controlled LFO oscillator with pulse/triangle wave selection and VC'd symmetry; an envelope generator with delay, attack and decay controls, external trigger inputs, and envelope output; and a VCA, controllable from the internal envelope, foot pedal, or Mediamix Joystick. The PLFO (\$189.00) can be used to modulate any voltage controllable synthesizer function. For a brochure, write Mediamix, Box 484, Verdugo City, CA 91406.....

....Another notable birth will no doubt further the cause of de-evolution. On June 24th 1978, **Alexandra Kathleen Mothersbaugh** was born to **Maria** and **Bob Mothersbaugh**, the latter a front line DEVO. Combined with the recent release of the group's first **Warner Bros.** album, **Q: Are We Not Men? A: We Are DEVO**, Bob must be having the time of his life. If you get a chance to see DEVO, do it. You'll be glad you did.....

It feels what you play, so you can play what you feel.

Feel the keyboard that feels your fingers. The Multimoog. It's a new synthesizer for the composer in you. And a new keyboard for the performer in you. And each key lets you touch a new dimension you've never felt from a keyboard before — expression.

Keys on most conventional keyboards are like on-off switches. When a key reaches bottom, the sound just sits there. So there's no room for expressing the sounds of a stretched guitar string, a bending saxophone reed, or a soaring violin vibrato.

But now you can put feeling into your performance with the Multimoog's force sensitive keyboard. You can actually guide the sound with the force of your fingers. Create vibratos, trills, or sample and hold. The keys actually feel how much expression you want to give.

While your right hand's playing what it takes two hands to play on other synthesizers, your left

can add a third hand to the sound. Move the music several directions by moving the modulation wheel. Or slide the pitch with the slide of your finger on the ribbon controller.

With all this action at your fingertips, you could almost forget there's a fully variable synthesizer in front of you. Multimoog lets you conduct your sound with two audio oscillators plus a low frequency oscillator, fully variable wave shaping, a long 3½ octave keyboard, single or multiple triggering. And more. Not to mention that famous fat Moog sound.

And thanks to Moog's philosophy, the music is never a side effect of the sound effects. The entire layout reads like a musical composition. With

controls you can get your hands on. After all, sound isn't music unless you can play it.

Stop turning the notes on and off, and start playing them. Touch the sound of the Multimoog at your nearest Moog dealer. And discover just how good music can feel.

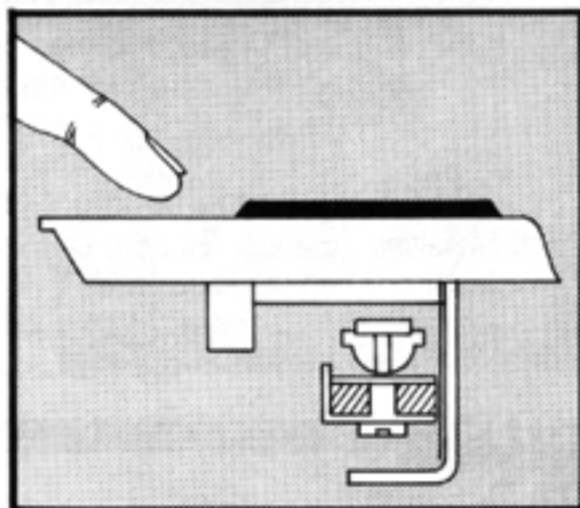

Keys perform like standard keyboard until they meet force sensor mechanism.

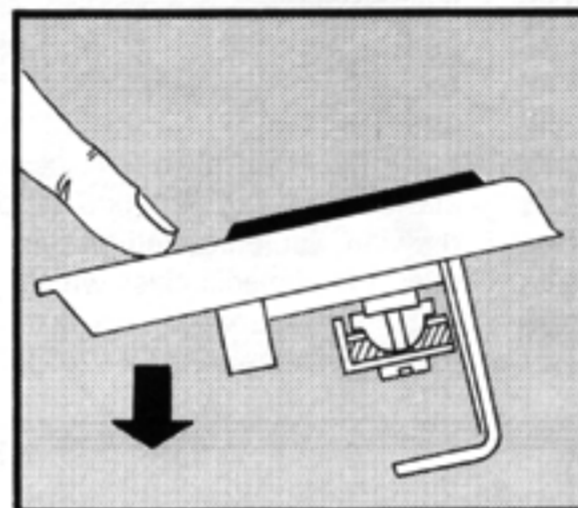

Force sensor mechanism translates amount of pressure into amount of expression.

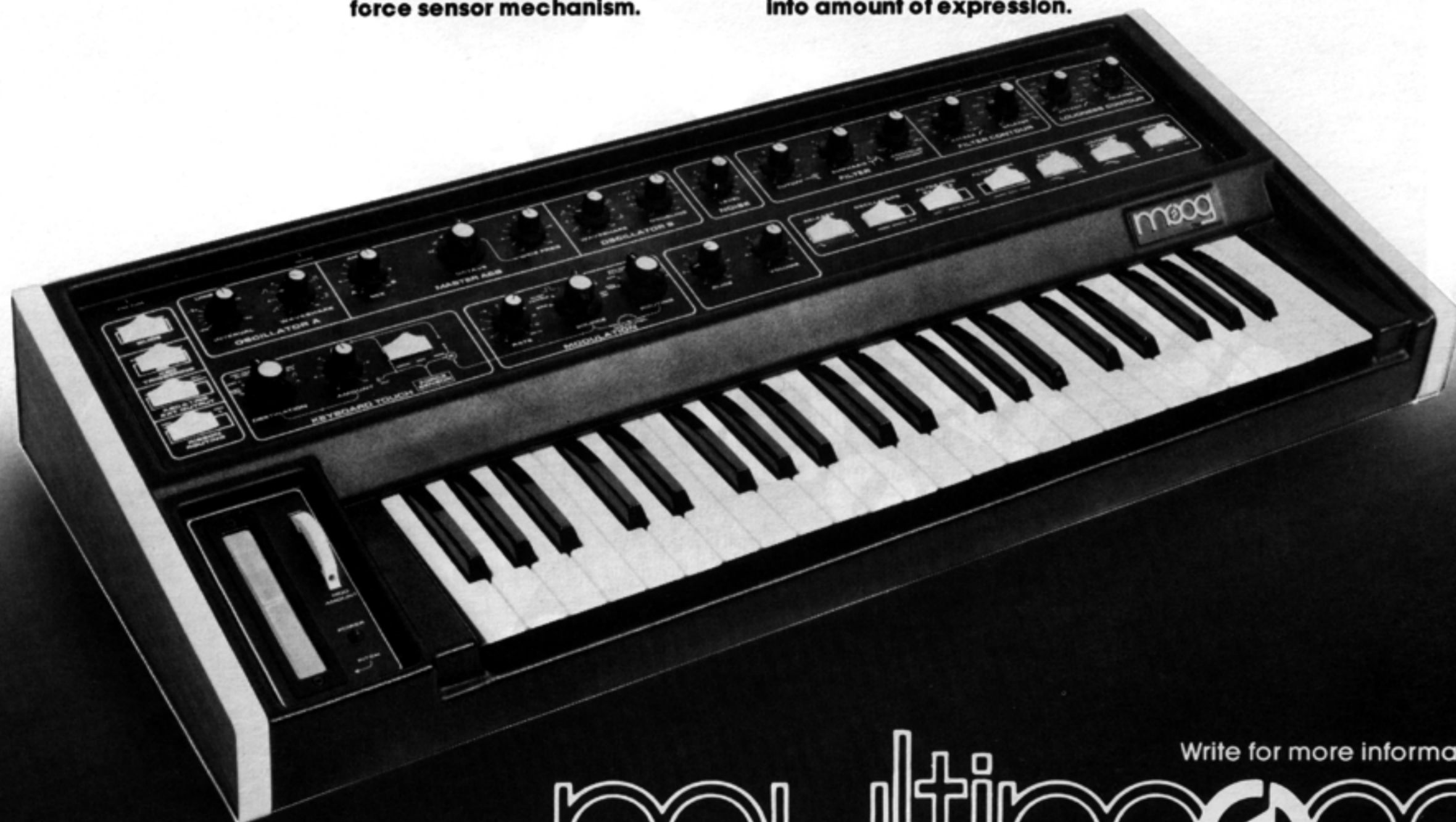

Norlin

For additional information, please write:
Norlin Music, Advertising Dept. SY-1
7373 N. Cicero Avenue, Lincolnwood, Illinois 60646
51 Nantucket Boulevard, Scarborough, Ontario Canada

Write for more information.
multimoog

Another quality product from Norlin

PROFILE

The Omega Inter-media center

The story of the Omega Intermedia Center, or perhaps more accurately of its principals, Pam Sloan, Frank Garvey and Peter Sheff, is one of opposition to what they perceive to be the popular stance of most universities and established music centers that all sounds are music, and view the music and art produced by these institutions as lacking in social connotations, and historically divorced from art. Calling this approach formalism, Frank Garvey explains the difference in Omega's approach. Whereas he feels that formal-

istic composers are taking "... the alienation from the factory and putting it in the concert hall, what Omega is trying to do is take the capacity for expression in music, and put that into the factory." The members of Omega believe that the technology necessary for this transformation is here, and that devices like vocoders present an immediate possibility for alternatives.

Although Omega is not yet operating on the level of these ideals, they have started an ambitious educational program, as well as a series of concerts using tape, live electronics, lasers and lumia projectors. Courses currently offered are Basic and Advanced Projects in Electronics, Multimedia Performance, Laser Art, Electronic Music, and Micro-computers.

The present curriculum reflects a process of trial and error. Founding member Pam Sloan said, "When we first started, we didn't know what the response to tech arts or the electronic arts medium would be, and having backgrounds in a lot of the arts, we started teaching things like painting, drawing, sculpture and plastics. We did offer a multimedia class which included just about everything we had, plus an

electronics class for basic electronic theory. It turned out that about 80% of our students were in those two classes."

The trend for independent electronic music schools to be operated and staffed by working musicians is continued at Omega, in the form of the group Megaton, comprising the above mentioned musicians. Their performances, like their classes, operate with a growing understanding of the relationships between technology and expression. The visual images are not a direct analogy to the sound as with a color organ (although John Smiley, resident lighting designer, would be very interested to learn of a system that produces an interesting relationship) but are controlled independently, and composed to express a total idea. According to Frank Garvey, public response to Megaton's concerts has been favorable. "We've had a lot of people come to the show and say they came wanting to dislike what we did because it was advertised as electronic music. And they were amazed that they could not bring themselves to hate it, and that they actually enjoyed the experience."

Omega was conceived as a direct

alternative to institutional education in the arts, especially electronic arts. In explaining why it was essential to form Omega, Peter Sheff said, "... I looked into graduate schools of music—I even had people invite me to come to their graduate schools of music—but they would allow me to do what I wanted if I did all the things they wanted. Omega is completely opposed to that. In our music classes we don't tell you what to do. We like to give you ideas in composition, ideas on how to organize thoughts, and ideas into music and art."

Political consciousness is easily the most unusual aspect of the Omega Center. Omega is very conscious of its role as an integral part of society, and not just representative of an isolated medium working independently of the world. Recognizing the fact that art and politics cannot be divorced from one another, they are attempting to go beyond turning out "product," and view Omega as a socially responsive organization. "For all of us, in one form or another, that is the reason why Omega exists. Because we refuse to accept certain aspects of the alienation of our senses." —Doug Lynner

Synapse

You've heard of word processing...and data processing. But have you heard of "music processing?"
With the Roland MC-8 MicroComposer you can store...add to...delete from...re-

Introducing the new Roland MicroComposer.

structure, and play back through a synthesizer as many as eight voice lines of your own musical composition. And you can do it instantly, as easily as pushing buttons on a ten-key adding machine. We call it music processing.

But that's just the beginning. The list of additional possibilities fills an entire volume.

Roland
The largest, most diversified line of electronic musical equipment in the world.

There's nothing else like the Roland MC-8. It is undoubtedly the ultimate innovation for recordists, musicians, composers and arrangers.



Let us tell you more about Roland's new MC-8 MicroComposer. Write today to Department 10-076, RolandCorp US, 2401 Saybrook Avenue, Los Angeles, CA 90040.

THE MS-10

The beginning without an end.

VOLTAGE CONTROLLED FILTER (VCF)

Shapes tone dynamically by selectively removing harmonics. Provides an infinitely variable selection of timbre.

PEAK CONTROL

Emphasizes the filtering effect by creating resonances at the cut-off frequency for effects such as Wah-Wah, Twang, etc.

VOLTAGE CONTROLLED OSCILLATOR (VCO)

Creates a 10-octave total range (exceeding both ends of the audible spectrum).

4-SELECTABLE WAVEFORMS

Triangle (flute, vibes, etc.); Sawtooth (brass, strings, etc.); Continuously variable Pulse Width (reeds to harpsichord); and White Noise (sound effects such as surf, storms, percussion, etc.).

PORTAMENTO

Controls the rate of "glide" between one note and the next.

EXTERNAL SIGNAL LEVEL

Lets you process external sound sources through the MS-10.

VOLTAGE CONTROLLED AMPLIFIER

Varies the volume of sound according to the signal you program with the Envelope Generator.

ENVELOPE GENERATOR

Controls the sound's rise time (Attack), its initial drop-off rate (Decay), the level at which the note is held (Sustain) and the rate at which it finally dies off (Release). Korg's unique Hold Control sustains the note for a variable amount of time.

PATCH PANEL

For ultimate flexibility and advanced applications. With plug-in patch cords you "create" your own combinations of the MS-10 modules. Also permits interfacing with (adding on) other synthesizers, sequencers, pedals, etc.

MODULATION GENERATOR

Creates modulation (i.e., repeating) effects ranging from Vibrato to Tremolo with Korg's unique Continuously Variable Waveform Control.

32-NOTE KEYBOARD

Creates control voltages for pitch and "trigger" for start/stop of notes.

FREQUENCY MODULATION

Controls the intensity of the Vibrato effect created by the MG section. Also controls the range of Pitch Bend.

FILTER MODULATION

Controls the degree of modulation effect on the filter, producing a range of sounds from gentle flute tremolos to a growl. Also controls the sweep of the filter.

PROGRAMMABLE CONTROL WHEEL

Programmable wheel produces multi-functions; i.e., Pitch Bend, Wah-Wah, Pulse Width, etc.

MOMENTARY MODULATION CONTROL

For instantaneous Vibrato effects.



Whether you're completely new to synthesizers or someone looking for a serious, but affordable synthesizer, take a good, long look at Korg's new MS-10.

We're showing you the MS-10's full complement of controls so you can compare it with anything and everything on the market.

Any synthesizer priced even close to the MS-10 will seem like a mere toy. Any synthesizer with close to the MS-10's capabilities will cost far more.

Incorporating the high-technology of Korg's renowned Professional Laboratory Se-

ries, the MS-10 is equipped with all the professional modules to produce an infinite variety of sounds.

And, unlike other synthesizers, once you master the MS-10, you won't feel like you've outgrown it. The Patch Panel lets you expand the internal capability of the MS-10, as well as interface with other synthesizers, sequencers and control units (such as the Korg MS-20 Synthesizer or the Korg SQ-10 Sequencer).

If the idea of Korg's new MS-10 is growing on you, remember, it will also grow with you.

THE MS-SERIES

KORG

Puts Synthesizers within reach.

Unicord Division of Gulf & Western Manufacturing Company, 75 Frost Street, Westbury, N.Y. 11590



Blank 001

Pere Ubu The Modern Dance

Something strange has been going on in Ohio since 1976, and the better percentage of rock-listening residents there are too busy listening to FM radio to take much notice. Already benefiting from the interested out-of-town ears of David Bowie and Brian Eno, is Akron's DEVO (short for De-evolution Band), which is making big noise from its base in the boonies with an intriguing combination of neo-scientific theorems that shift Darwin in reverse, turning standard rock riffs inside out and setting them to an androidal beat—ergo their version of the Stones' "Satisfaction."

Crosstown rivals like Tin Huey and the Bizarros stake their own claim, marking stylistic time with avowed influences like the Velvet Underground, Gong, and even Germany's avantish Faust. But the forerunner of this Ohian activity, at least in the sense that they recorded first, is the five-piece Pere Ubu, hailing from Cleveland and aptly depicting in sound the cold industrial climate of that city, as set to a hypnotic but idiosyncratic rock 'n' roll score which singer David Thomas begrudgingly admits could be described as "punk in the 21st century."

In twenty-five words or less, you could then program Pere Ubu's debut album, *The Modern Dance*, as "Hawkwind goes ten rounds with the Chocolate Watchband as the spirit of Eno lurks about the fringes with a refereeing eye." But the group, taking its name from a character in a Dadaist play by Alfred Jarry, is not even that predictable. Thomas—occasionally known as Crocus Behemoth—may sing with the same wolfish spirit as Captain Beefheart, but he professes as equal a love for the music of Abba, and insists Ubu's music is good pop, full of hooks and highly commercial.

Sales notwithstanding, this album, and the four independently released singles preceding it, literally burst at the grooves with Class-A guitar runs.

"Non-Alignment Pact," "The Modern Dance," and "Street Waves" all draw from the same well, railroaded by Tom

Herman's grating guitar sound and the motorized rhythm section of bassist Tony Maimone and drummer Scott Krauss. But where Pere Ubu outdistances the competition and escapes the categorical curse of "New Wave" is in their elliptical lyrical vision, Thomas' startling vocal style, and the stark electronic landscaping of Allen Ravenstine's bank of synthesizers.

The key to Ravenstine's role is the fact that he never gets a starring solo spot and is always dropped back in the mix behind the others. Rather, he manipulates the dials with an ear for dramatic counterpoint to what the rest of the band is doing. On "Life Stinks" (a sarcastic aside at punk nihilism), Ravenstine lets go a rapid fire series of tones like Morse Code gone crazy, while the band gathers its breath for the second manic chorus. Alternately, "Real World" finds him bending long, spacious notes that sound like quarter-tone lunch whistles while Thomas defies octaves, singing about life in a real world outside—one assumes, the tarnished chrome and industrial exhaust of 9 a.m.–5 p.m. Cleveland. In between Thomas and Ravenstine, the rest of the Ubus twist chords, harmonics, and time changes in a committed, sometimes defiant manner calling to mind Can's *Tago Mago* LP, as well as sharing instrumental affinities with Beefheart's *Magic Bank* circa *Trout Mask Replica* and *Lick My Decals Off, Baby*.

Ubu nearly oversteps even their extended bounds with "Sentimental Journey," a six-minute barrage of broken glass, synthesized outbursts, and psychotic ramblings redeemed by its dramatic realization in performance. But somewhere between that and the punky three-chord abandon of "Non-Alignment Pact" (love equals Cold War) stands the essence—the catalysing sound and fury of this album and the English EP (*Datapanik in the Year Zero*) which collects most of their early singles. Pere Ubu have translated the punk ethos of energy into daring new sonic terms easily eclipsing most of the arty residue already washed up by the New Wave. Dada would be proud.

—David Fricke

Be-Bop Deluxe Drastic Plastic

"I speak to you through electrical language / Sometimes you hear me, / When our frequencies meet . . ."

(c 1978 W. Nelson, Arnakata Music Ltd.)

Way back in the almost nostalgic days of the early '70s, influential British DJ, John Peel, was regularly heard to mutter over the airwaves that Be-Bop Deluxe and their guitarist/leader, Bill Nelson, would be superstars one day, and that we all should . . . etc. etc. "Who?" the cognoscenti asked. Well, Mr. Peel

had said the same about David Bowie as early as 1968, and it seemed that his visionary prophesying was going to be proved right once again. *Drastic Plastic* is an excellent album that would probably have made the band's reputation in the US. Unfortunately Be-Bop Deluxe have just broken up, leaving one more album, to be released later this year.

After one live and four studio albums, plus wide critical acclaim and commercial success in the UK, it seemed strange that Nelson and Co. could do no better than play support gigs in this country. Much of this was due to confusion over the band's image. Many people were unsure whether Be-Bop played heavy metal, "glam" rock, or artsy "space" rock, an impression confused further by Nelson's onstage preoccupation with wearing immaculate suits and a Vidal Sassoon haircut. What was undeniable however, was that Nelson seemed to be a very inventive guitarist, if somewhat self-indulgent, particularly in concert. Owing his roots to Wes Montgomery, Jimi Hendrix and Jeff Beck, Nelson borrows musical styles from everywhere, yet succeeds in fusing them together into a sound that is undeniably his own.

Drastic Plastic is by far the band's best album to date, and consolidates the line-up that was first cemented on the third album, *Sunburst Finish*. For the first time, everything has come together: the band works as a unit, and Nelson has integrated his guitar into the total structure of the music. This of course makes the break-up all the more disappointing, yet Nelson felt that after six albums the time was right for a change.

Nelson plays both lead and rhythm guitar, and also, on two tracks, a Hagstrom/Ampeg Patch 2000 guitar synthesizer, fed through a Minimoog. Charlie Tumahai on bass and Simon Fox on



Harvest SW 11750

drums provide the rhythm section, while Andy Clark complements Nelson's virtuoso guitar with often complex atmospheric backdrops on his Poly- and Minimoogs.

The opening track, "Electrical Language," features the guitar synthesizer and is very reminiscent of Steve Hillage's recent work, both in terms of overall sound and lyrics. Nelson repeats the same verse throughout the song, extolling electrical language as a form of communication: Motivation Radio Part

2. Clark's synthesizer melody patterns are overlaid initially by Nelson's lead guitar, which is untreated, and then by his phased guitar synthesizer, which repeats his earlier riffs before launching into some very tasteful solos. As the song progresses, the sound completely gives way to phasing and Nelson duets with himself in a potpourri of echo. The piece is kept very tightly co-ordinated however, by the constant pulse of Simon Fox's drum tape loop. As if to complete the unity of sound and lyric, Clark simulates wedding bells on the synthesizer as the track fades out.

The almost naïve optimism of "Electrical Language" gives way quickly to a foreboding of doom. Nelson manages to infiltrate his pessimistic vision of a decadent, technological future into a framework that seems to simultaneously delight in that technology. He claims to have been strongly influenced by Bradbury and Vonnegut, but it is the Fritz Lang of *Metropolis* who is his clearest mentor. That film condemned a futuristic society regulated by "the machine," yet revelled in the special effects it made possible. Be-Bop Deluxe, in fact, screen extracts from this film during their concerts, so the comparison is quite apt.

"New Precision" is a free associating impression of a world that is shutting down: "See what tomorrow brings, A hint of genocide . . ." (c 1978 Arnakata Music), dominated by a military drum tempo beneath Nelson's heavy metal guitar, white noise and oscillations. "New Mysteries" is similar lyrically, a surreal world of enigmatic imagery, a Jungian shadow world of the unconscious. One is reminded simultaneously of Eno, Bowie's crooning, and early Cream, yet the white noise and Clark's gurgling synthesizer suggest something less clearly defined.

"Surreal Estate" is an escape into a timeless world, a cheerful tune with a lilting melody, strong harmonies on the choruses, and a "clippety-clop" rhythm, punctuated by various sound effects on pots and pans, bells, gunshots, and train whistles. After a quote from "The Long and Winding Road," Nelson's cheery whistling chorus breaks into a refrain of "Whistle While You Work," underlining the Disneyesque contrast with the earlier Langian expressionism.

The interlude doesn't last long however, as side one ends with "Love in Flames," a blistering heavy metal rocker, counterpointing Nelson's wild guitar with Clark's simplistic keyboards (his synthesizer is used to emulate an old Vox continental organ). It sounds just like *Deep Purple in Rock*.

Side two is, if anything, even better, being more minimal. "Panic in the World" muses on the coming holocaust accompanied by a chugging bass, a spare guitar sound and an almost fairground-like organ (Moog). It frames the other tracks with the closing cut,

DISCOLA

"Islands of the Dead," an auspiciously escapist flight to the afterlife, featuring an ironic simulation of an Hawaiian guitar and gentle, lulling vocals, reminiscent of Eno on "On Some Faraway Beach."

The remaining tracks offer a cynical vision of contemporary society regulated by media and self-image. "Dangerous Stranger" is Nelson's pessimistic, down to earth answer to Bowie's "Starman"—a boy who rides off along the highway with a stranger but changes his mind and wants to go back home—too late, as they drive off to the end of time. To complete the parody, Nelson even emulates a Mick Ronson guitar solo.

"Superenigmatix" is an Eno-like ditty about "lethal appliances for the home with everything," featuring an effective contrast of the acoustic and electric, as Nelson wields his synthesized guitar in heavy rhythms reminiscent of The Who. This latter comparison is even more apt on "Possession," as the Pete Townshend guitar style is reinforced by the late Keith Moon's trademark—machine-gun drumming. The sound is filled out by subtle trills on the synthesizer during the choruses.

The most accessible cut on the album is "Japan," with Clark's synthesizer emulating an archetypal Japanese percussive melody (shades of the Sadsitic Mica Band), as Nelson croons his love for Japan in undisguised cynicism:

"I would like to wander under
oriental stars . . .
Playing modern music on my
Japanese guitars . . .
You can hear me on your cheap
transistor radio . . .
Tuning in to endless love from down-
town Tokyo . . ."

(c 1977 W. Nelson Arnakata Music Ltd.)

If **Drastic Plastic** is any indication, Be-Bop Deluxe's swan song should be well worth waiting for. Meanwhile, be on the look out for Nelson's new band, Bill Nelson's Red Noise.

—Colin Gardner



Virgin V2098

Steve Hillage Green

It is always interesting, when listening to a familiar artist doing something new, to figure out what has changed,

what has not; what works and what doesn't. In the case of **Green**, the latest solo album from Steve Hillage, not too much has changed, but somehow it doesn't work the way it did last time around.

Steve's playing is as tasty as ever, but there is little opportunity for him to really shine in this capacity because of the nature of most of the material. Sassy, heavy metal fills such as on "Light in the Sky," or adrenaline rushing solos as on "Hello Dawn" just aren't there. Steve's soloing is good, but it has nowhere to go most of the time, so it tends to run on too long. "Unidentified" is one example of this. A funk tune whose bassline quacks its way from beginning to end, this format offers little in the way of changes for Steve to build on. For him, this approach may be something new; for the rest of us, it isn't. He does a good job with what he has, but why the limitations?

Another main complaint is the lyrical content of this album. It is enough to hear once or twice that we should, "Strip away our thinking minds/To unlock the love that's deep inside/And destroy all those clumsy words/To feel the energy they hide." This kind of talk is not altogether uncharacteristic of Steve, but it doesn't work as well this time, and the lyrics tend to take on a kind of Girl Scout proselytizing quality that does more to alienate than to persuade. Partly because Steve's writing is lacking in direction, it almost seems as if he is trying to persuade himself of his own message. When the lyrics are not pounding the listener into the ground with their anti-intellectual injunctions, they are so cryptic that it is unlikely many people will get their message at all. So much for the parts that don't work.

Although this disc is distinctly lacking in the heavy metal hits that made **Motivation Radio** such an accessible album, there are some moments on it which approach the ecstatic. "Underwater Vocoder Poem" is one of these. It is impossible to describe the feeling Hillage evokes here; but listening to Miquette Giraudy speaking-singing through a vocoder, one has a true feeling of being at once under water, and at peace. The only drawback of this cut is that it is so short. Another piece which has the capability of lulling the listener into a dream-like state is "Leylines to Glasdom." Here, a haunting melodic line introduced with a high "singing" synthesizer, is made all the more soulful when played on guitar. This piece is fortunately long enough to enjoy for awhile. Other cuts which stand out are "Ether Ships" which creates some nice images, although the guitar solo is a bit meandering; and "Palm Trees" where Steve does some nice work with time delay techniques.

The production work of Steve & Nick Mason is fine, as is Giraudy's work with ARP and EMS synthesizers. Curtis

Robertson and Joe Blocker provide adequate support on bass and drums respectively. The timbres and spacial effects are all well done, and presumably are meant to transport the listener into a meditative state. But there is a certain lack of spark—to use a Hillage word—and instead of becoming meditative, one just gets restless. —Melodie Bryant



Bearsville BRK 6981

Todd Rundgren Hermit of Mink Hollow

Todd Rundgren is an artist in a constant state of evolution. From the early Nazz albums, where he gained his first experience as a writer, producer and arranger, his music has taken many different forms. With this disc, Rundgren returns to an earlier format—that of the solo album.

Because he plays all the instruments himself, much of the Utopia influence is gone. Many fans will breathe a sigh of relief that Rundgren has given up this high energy, virtuostic approach; although, in keeping with his total growth, he has not abandoned it altogether. Cuts like "Bread" and "Out of Control" could have easily appeared on a Utopia album. It's just that this influence is no longer the prevailing one.

With the absence of Roger Powell, synthesizer is not usually featured on this LP; and where it is used, it is not in soloistic fashion. "Luck Guy" contains an interlude consisting totally of synthesizers, as does "Can We Still Be Friends"; but these are exceptions. Generally, although synthesizers are played throughout the album, they are used more for subtle touches than for musical statements.

True Rundgren freaks will recognize many ties with earlier albums. From the anthem-like "All The Children Sing" to "You Cried Wolf," a continuation in a series of nostalgic pieces, all recognizable elements for a Rundgren album are there: even the silliness ("Onomatopoeia"). The nicest thing, though, is the balance which this album achieves. Todd's talent as a writer is finally allowed expression through his experience as a producer. The over-production which plagued so many of

his other albums is gone; but not the unique ability to weave voices, synthesizer, and guitar into a whole. This kind of balance is pleasing and rare; but it is probably not the end of the evolution for Rundgren, merely another stopping point.

As his last appearance in LA showed, he has not yet ceased to experiment. His Roxy show featured mime, dance, a cappella singing, and video monitors, in conjunction with a full musical performance. The **Hermit of Mink Hollow** is a fine album. Listening to this LP, one wonders what he will be up to next.

—Melodie Bryant



Warner Bros. BSK 3239

DEVO Q: Are We Not Men? A: We Are DEVO!

DEVO are essentially collage artists, both in terms of their philosophy of de-evolution and their music. Like Dada they take pre-existing material and mould it together in strange juxtapositions producing an end result that is more than the sum of its parts. Thus clichés can be synthesized into interesting statements, or occasionally merely more clichés.

"Are we not men?" for example, is taken from **The Island of Dr. Moreau**, but is given new life by combining it with a reversal of Darwinist theory of evolution which contends that man has evolved too far and degenerated. Yet DEVO also introduce an element of egalitarianism insofar as "We are all DEVO," and presumably spuds also—united as one in our common pinhead existence.

This is a very winning thesis for our current times, providing a simply understood alternative, a collective consciousness, and a pseudo-scientific logic for attacking the status quo. Moreover, the music is extremely accessible, rooted firmly in the rudiments of rock 'n' roll, with enough off-beat electronics and minimal production values to appeal to the discerning and faddist avant garde.

Yet DEVO's approach has certain

Rick Coupland has just Re-Invented the Synthesizer.

Every performer knows exactly what's wrong with keyboard synthesizers: they're not really **performance** instruments.

The Coupland Digital Synthesizer is designed to be played. Not tweaked and fiddled with. The computer does all that, instantly. The composer can spend his time composing. The performer can spend his time performing.

But that's just technical stuff. The important difference is the sounds. You don't just select or modify sounds. You **design** sounds. Your sounds, not somebody else's. You create and perform in your own style.

The Coupland Digital Synthesizer can create virtually any musical sound ever heard on earth. And the sounds that have never been heard. Really.

Maybe you'll never believe all this... until you hear it. Then you'll believe.



Coupland Digital Synthesizer, Model One
where the next new sounds will come from.

Coupland

DIGITAL SYNTHESIZER

Micor Inc. · Audio Products Division · PO. Box 20885 · Phoenix, Arizona 85036
(602) 273-4381

Rick Coupland: genius,

musician/composer,
computer programmer, inventor,
and well-dressed-man-about-town.

intrinsic problems. As in any creative endeavor whereby one criticizes the status quo by exaggerating its worst abuses, the more effectively to underline its irrationalities, one tends to fall into the trap of using those same abuses to further one's cause. Thus DEVO's use of cliché, repetition ("We must repeat, D.E.V.O.") and insistence on ideology, can be read as dogmatic—a wonderfully convenient doctrine for DEVO clones to adopt as they dress up in their DEVO uniforms and Booji Boy sunglasses: DEVO as another consumable fad! Similarly, the need for an audience has led the group to abandon their home-made label for the affluent comfort of Warner Brothers, 24 tracks, and Brian Eno as producer. The end result is a slicker, more polished product, which deviates from the original ideal of crudely minimal electronics.

The music itself is both derivative and simplistic, yet somehow exciting, original and fresh: like a Man Ray exhibit, although more musically akin to Tuli Kupferberg and The Fugs. Its main characteristic is a tendency to make the listener want to pogo in robot-like jerky rhythms. DEVO borrow from a wide variety of sources, yet create a sound that is undeniably their own, even without the enhancing props contained in their live shows. Thus their version of the Stones' "Satisfaction" bears more resemblance to old Jamaican ska singles from the early sixties than to R & B. The fuzz guitar riff dominance has gone, replaced by a grumbling bass and staccato percussion, and when at the end we finally get our fuzz guitar, it's played on a synthesizer.

"Come Back Jonee" extends the folklore of J.B. Goode by killing him off completely. Chugging guitars join a simplistic Farfisa organ, Chuck Berry riffs, and a grisly out-of-tune chorus yelling "Jonee! Jonee!" as we hear that: "Jonee jumped in his Datsun, Drove out on the Expressway, Went head-on into a semi-, His guitar's all that's left now."

"Praying Hands" features influences from surfing instrumentals ("Wipe Out") to The Beach Boys' acid experiments ("Smiley Smile"), while "Uncontrollable Urge" has marked elements of The Pretty Things, The Who and Tom Petty. The screaming guitar, crashing cymbals and gorilla grunts of "Too Much Paranoias" recall King Crimson's "21st Century Schizoid Man." The one major DEVO hallmark is Mark Mothersbaugh's voice, which sounds at times like Bryan Ferry flipping out, yet often contains great conviction. It has to with lines like, "I think I've got a Big Mac attack."

Only "Jocko Homo," "Shrivel Up" and "Mongoloid" make overt references to de-evolution. The latter is Jerry Casale's ode to the modern nine-to-five, which owes a great debt to the Kinks' "Well Respected Man," yet carries the novel overtone that "Mr. Status Quo" is also mongoloid: "one

chromosome too many." "Shrivel Up" is an uncharacteristically moody piece, reminiscent of those edgy "Twilight Zone" TV soundtracks. Once again DEVO refer back to an old idea, in this case that Jack Ripper's theories of defluidation in *Dr. Strangelove* were erroneous. It wasn't the Reds who were robbing us of our vital bodily fluids—it's in the natural order of things.

"Jocko Homo," the band's anthem, is perhaps their most original piece. Deceptively simple in its counterpointed ascending and descending riffs, it succeeds on its own terms without resort to musical clichés or electronic gimmicks.

The use of synthesizer is understated rather than overt, employed to reinforce a melody line more often than for experimental atonal counterpoints. Thus Eno plays one of his rhythmic interludes on "Gut Feeling," very reminiscent of his early Roxy Music contributions. "Space Junk," an amusing report on debris falling to earth from outer space, and "Too Much Paranoias" both use electronics as sound effects, usually very percussively.

DEVO are an accessible force—Toni Basil's use of their music in her "Follies Bizarre" is proof of that—and they continue to grow. In fact their current singles, not on the album, "Blockheads" and "Machine Man," are far more interesting electronic experiments than anything on *Are We Not Men?* It remains to be seen how far Eno has affected their evolution—or rather de-evolution.

—Colin Gardner

Lyrics © 1978 DEVO Music/Virgin Music Ltd.



London PS-708

The Moody Blues Octave

At the dawn of the Mellotron age stood, A band of Moody Blues who prophesied the common good.

They spoke with cosmic knowledge
And garnered golden sales,
Then went their separate ways,
Some to L.A., others Wales.

Hark! My rock and roll children,
For they have found the slender thread,
To get their incomes going
In Search of Their Lost Bread . . .

—Greg Allen

Craig Anderton The Craig Anderton Music Tape

The Craig Anderton Music Tape is more of an educational tool than an entertainment product. A book is furnished with the tape that contains the lyrics and a description of what instruments and accessories were used on the tracks of each cut. At the end, Anderton lists the equipment used in the project, and it is not surprising to find a TEAC A-3340S, a home built mixing board, electronic drums, and a host of home built processing devices contained therein.

The Tape came about as a natural extension of Anderton's columns and articles in many music magazines, where he championed musical self-sufficiency through home recording with inexpensive, and often home built, equipment. The Tape is the perfect medium for bringing his written ideas to life, but the transformation is a double-edged sword. The music serves well to illustrate the use of home recording techniques and equipment, but is unfortunately the weakest link in the package. The music has a very 60s feel to it and lacks in development. It breaks no new ground, nor is it commercially perceptive. The material ranges from the absurd, as represented by "Roy Herful," a test for a new flanger design which turned out to be a funny gnome-like piece with backwards vocals (an inadvertent tribute to meaning in pop lyrics, since it works just fine) to California Slick as on "Champaign and Caviar." Craig Anderton is a guitarist, so the tape is overflowing with every variety of processed electric and acoustic guitar. This cut starts out with light guitar, soon joined by electronic drums and, of course, more guitars. A break features an overdubbed ensemble of E-bow driven guitars forming a sonorous and bouncy pick up to the next verse. The singing on the Tape is generally inconsistent and too dominant in the mix, but this song provides a welcome exception.

The aspects most open to review on the Tape are: the success of the devices he built, his use of them, and his recording and production of them. All in all, the devices do the job, and generally well. It is, however, impossible to be very discerning of things such as noise problems, since everything is processed, recorded on a four track, copied onto cassette, and will perhaps be played back in questionable circumstances. The projects from his book, *Electronic Projects for Musicians* (GPI Publications), are all used, as well as projects from his columns. Most of Anderton's uses of these devices are very adept, but again, as with the songs them-



selves, no new ground is broken. The most used recording alteration on the Tape is backwards playback of recorded tracks. Although I believe it helps create the dated feeling of many of the tunes, I also think Anderton has revived a rich resource of sound for home recordists. As for the recording itself, Anderton has proven, as others have, that home multi-track recorders can be used to record an album, and that it can be as simple or as complex as you want it. The quality is good—not great, and not as good as other four track tapes I have heard—but it works. That is the important part.

Of special interest on the Tape is the electronic percussion, designed by Anderton. It can be pre-programmed, or manually operated. Not enough attention was paid to the timbre and presence of the percussion sounds, especially considering Anderton's versatility in this area, but they were different and allowed the tunes to sometimes be more than just a memory of musical times gone by.

When all is considered, the most unusual thing about the Tape is that it is manufactured and distributed by PAIA, an electronic hobbyist company specializing in synthesizers. I'm not positive it's the first such release, but it is at least one of the first, and provides a new avenue for musicians trying to get their music out. PAIA is to be congratulated for not encasing it in hype. It is not a company demo.

Anderton is working on his second offering, a record this time, also to be distributed by PAIA. I look forward to listening to his progress.

—Doug Lynner

The Craig Anderton Music Tape is available from PAIA Electronics Inc., 1020 West Wilshire Blvd. Oklahoma City, OK 73116

Frank Garvey Labyrinth

What has Chicago's newest synthesist, Frank Garvey, chosen as a theme for his first album? No, it's not about machines beating up blue collar workers. Nor is it about robots pushing vacuum cleaners while plotting man's destruction. Well then, it must aurally describe rocket ships *sshwhishing* through interplanetary galaxies searching for a practical home computer-music system, right? Wrong. It's something a little more original and down to earth—Gary Gilmore, the psycho-criminal who couldn't wait to plug in his own

Continued on page 43

Craig Anderton Meets Combo Organ, The Result: **ORGANTUA**^{T.M.}



from

PAiA

Forget about thin-sounding combo organs; ORGANTUA has: three individual ranks (each with 5 position octave select switches) for a rich, thick sound.

ORGANTUA represents the first major advance in combo organs in 10 years.

Send for our instruction manual. It tells the full story.

no. 6780 — ORGANTUA Kit —
\$279.95
(shipped freight collect)

PAiA DEPT. 9, 1020 W. WILSHIRE, OKLAHOMA CITY, OK 73116

**Also available
custom
assembled,
write for details.**

- I'm convinced — Send ORGANTUA Kit — \$279.95 enclosed.
 Send ORGANTUA Instruction Manual (\$5 refundable w/kit purchase) Send FREE Catalog

Name: _____

Address: _____

City: _____ State: _____ Zip: _____

PAiA DEPT. 9S, 1020 W. WILSHIRE, OKLAHOMA CITY, OK 73116

David Behrman's Minicomputer Workshop

The most exciting event looming on the horizon of electronic music is the impending shift from analog electronics to digital and digital/analog hybrids. Prominent among those making use of the latest digital technology is David Behrman, co-director of the Center for Contemporary Music at Mills College, member of the Sonic Arts Union, and long associate of the innovative Merce Cunningham Dance Co. During June 26-29 he presented a workshop in "Homemade Instruments using Microcomputer Technology and Software," culminating in two concerts on June 30 and July 1. This series was part of the artist-in-residence program sponsored by 80 Langton St., a contemporary performing and gallery space south of Market Street in San Francisco.

David Behrman is particularly well suited to introduce artists and musicians to this technology because his background is in music and not engineering. He composes for a musical end product, often intuitively, not for a dry, contrived theory. On the first evening he presented a "program in progress," concerned with mapping the most resonant overtones sung by a live singer.

When the computer is ready to accept sounds from the live mic it signals Behrman's homemade bank of triangle wave oscillators, which emit a gradually rising pitch. The vocalist now sings into the mic and the computer analyses the sound by internally making a type of graph, plotting frequency of the live sound against its amplitude. It records any peaks, i.e. frequencies of the incoming sound which are particularly strong. When the computer has finished accepting information, the sliding pitch is shut off and the computer then tunes the analog oscillators to play back these overtones. At present these are heard in a strict descending order rather than the order in which they were received. Thus after the initial electronic rise in pitch, with its impro-

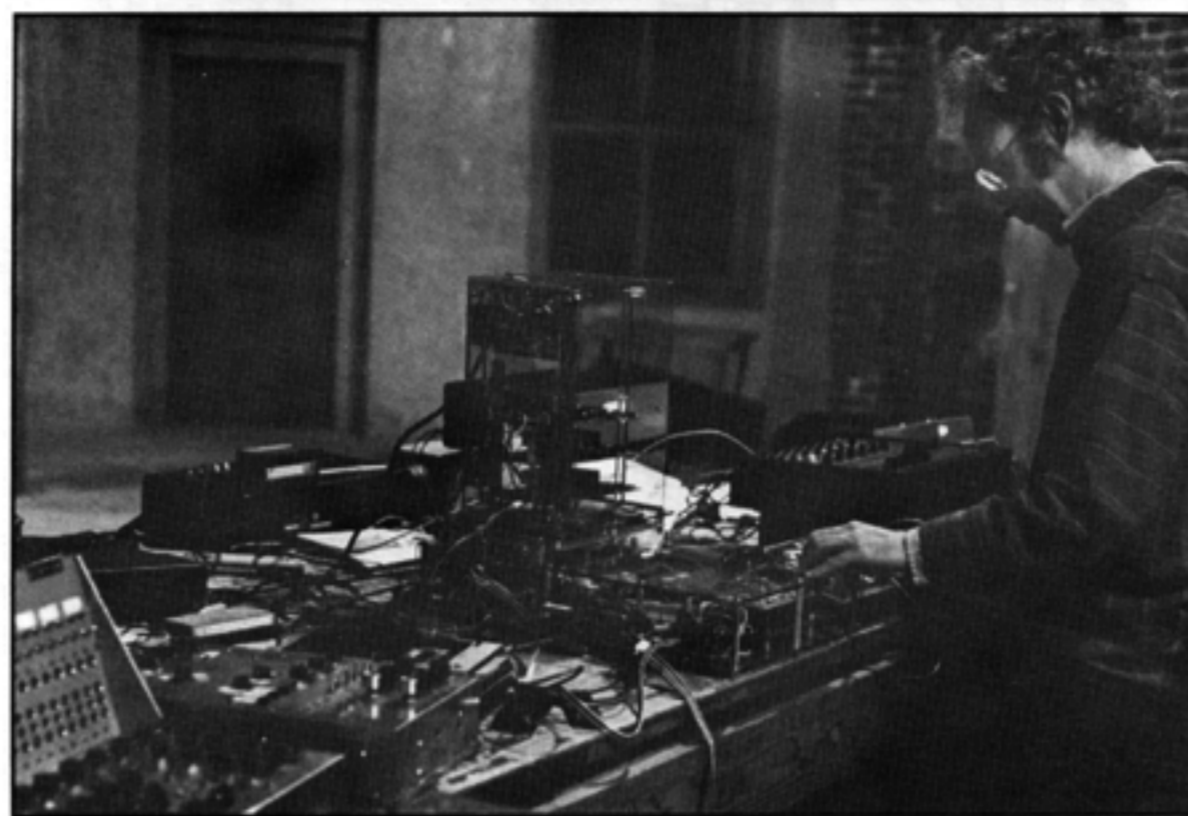

PHOTO: TERRI HANLON

David Behrman and Friends

vised vocals, there is a shorter fall which highlights frequencies taken from the material just heard. The upwards gliss then begins again as the computer asks for more vocal information.

During part of three other workshop sessions, Behrman arranged for other composers working with minicomputers to present their work. Firstly, Paul DeMarinis explained his program for shifting the pitch of an incoming signal in real time without changing its time base. He explained his interest in seeing how far one could push the alteration of speech before the meaning is beyond the listener's comprehension. He found that for this type of pitch shifting, the limits were rather tight, being approximately an octave.

The workshop highlighted the differing approaches of Behrman and DeMarinis. The latter's program is short and could be written on as little as half a page. Behrman in contrast informed us that he was looking over the program for the concerts which he had written over a year ago, and had trouble remembering all the twists and turns as it was over 180 pages long.

"Real Time Computer Network Music" are a trio of minicomputer artists, John Bischoff, Rich Gold, and Jim Horton, who initially developed their programs separately, but later formed an interactive configuration. Data from one minicomputer was fed to the next, and determined part of the sound that the second minicomputer produced or controlled. All three produced a constantly changing exchange that could produce hours of uninterrupted listening, and their piece

created a delightful sonic environment to gently move about in, and converse with the musicians about their work.

Bischoff's program was written for an installation at the Works Gallery in San Jose. He was interested in sounds with high noise content of various duration with "relatively long silences in-between" (1/4-1 second). He uses no analog oscillators: the computer produces the saw-tooth and triangle waves; and his program adds "funny sidebands" to the saw-tooth waves to enrich the noise nature of the sounds. The pitch moves in one direction to some varying limit written into the program, then it jumps to the opposite extreme and begins moving in the same direction as before. The length of time of both sound and the silences between is variable, and there are controls available to "weight" the amounts of silence towards one range or another.

The basis for Jim Horton's program is a 29 note scale proposed by the late Max Meyer's theories of melody. In simplified terms, each note that is played limits the possibilities for the next note. Meyer defined a set of rules and Horton's program is written around them, producing very pretty melodic lines reminiscent of Bach, Handel, and occasional hints of The Beatles.

Gold's inspiration for his program was **Fictional Culture**. About a year ago he began a large piece based upon an imaginary society, and most of the details about these beings and their environment were created and stored on programs. The pitches for the excerpt from this long and involved piece are based

on the topology of the imaginary landscape. Thus as an imaginary traveller encounters hills the pitch rises, and then falls for valleys. Each of these trips is in the form of lissajous figures, familiar to those who work with oscilloscopes. Gold commented that it was easy to recognize his program because it could sound like anything.

Phil Harmonic was the final computer artist to present his work. He is interested in minicomputer work which can be used in traditional concert environments as well as "in unusual spaces where such audio-visual presentations are not usually expected." Thus for example, several years ago he presented a piece in a supermarket which greatly amplified the sounds of the store for the shoppers. His latest plan is the "eminently portable 'Restaurant Synthesizer'", which will have the potential to bring user programmable sounds to all environments.

Minicomputers relate in two ways to his work. They are "dandy" random number generators, and are able to monitor real time conditions while performing other functions. His current applications of this are in his "continuing research with the I Ching," and in suggesting musical activity derived from slowly changing weather conditions. "Blue" Gene Tyranny has agreed to record a solo keyboard version of this piece, entitled "Weather," on the Lovely Music label.

On the Friday and Saturday nights Behrman performed the same piece, involving minicomputer and live improvising musicians. The latter were Maggi Payne, flute; Erv Denman, homemade electronic bass; and Bonnie Barnett, extended vocal techniques. The piece has been released as **On The Other Ocean** (Lovely Music, 463 West St., NYC 10014).

The liner notes explain that the piece "is an improvisation for live musicians centered around six pitches which, when they are played, activate electronic pitch-sensing circuits connected to the 'interrupt' line and input ports of a minicomputer. The microcomputer can sense the order and timing in which the six pitches are played and can react by sending harmony-changing messages to two handmade (analog) music synthesizers. The relationship between the two musicians and the computer is an inter-active

PERFORMANCE

one, with the computer changing the electronically-produced harmonies in response to what the musicians play, and the musicians influenced in their improvising by what the computer does."

Saturday night was a stunning presentation, with masterful performances by all three instrumentalists. Maggi Payne, who also plays on the recording, manifested excellent taste in allowing space to the other performers and the electronics. Bonnie Barnett is an advanced practitioner of extended vocal techniques, and a Dutch new music journal "Interface," has published her paper, **Aspects of Vocal Multiphonics**, which is now available in the US with two accompanying tapes (920 Van Ness No. 2, San Francisco 94109).

Erv Denman's homemade instruments have a sculptural quality about them which make them visually as well as sonically distinguished. On this occasion, his fretless bass (constructed entirely of drift wood found washed up on the mud flats of the San Francisco Bay) was played into a Mutron Dual Phaser and then a mixer. His instruments are currently on display at the San Francisco Art Institute as part of their "Forms of Sound" show.

The entire project was a large success, with the workshops presenting both technical, philosophical/aesthetic, and practical materials; and Behrman and the invited guests were always available for discussions. Most satisfying was the final Saturday concert, which illustrated that this technology can produce art of high quality, and that these composers' theories and premises can be materialized into lush waves of gorgeous sound.

—Bob Davis

DEVO

Starwood, L.A. October 10.

It took him minutes/Took her nowhere
Heaven knows she'd've taken anything
All night/She wants the Young American

—David Bowie, "Young Americans"

We want the Young American, goddammit. We want him real bad, and we're waiting dribbling in the sloppy hope he'll come knocking on our cell doors and let us out. We demand to have some heroes around



Earnings now for the future!

here. Load up those Dylans and Beatles **right now**. So what if we have to heap those needs on some pretty unlikely shoulders ("Poor Bruce" Springsteen, for example) and watch to see if the poor boobs get squashed flat. We will do anything rather than live with the lack of that Big Symbol we can use to plug into the big zero of our inadequate lives. And sure, we'll take anything.

Even Devo. And Devo are perfect **antiheroes**, Inspector Clouseaus of the music-art-pop world. They don't stand for anything, they don't hope to change anything, they don't want to be anything except **themselves**, that is, a painfully accurate caricature of the very people who are turning to them in desperate need. **Ouch**. Just **imagine** if Devo catches on real big, legions of de-evolved Devotees stomping around deliberately acting ineffectual, oafish, pathetic, robotic, absurd and somehow ridiculously noble, i.e. **exaggerated parodies of themselves**. Enough to make you wanna **cry**. Is this what replaces James Dean?

But don't worry, things are leveling out. Whew. Had you worried for a minute, huh? Thank God Devo are no longer quite themselves or things could get pretty nasty around here. A year ago people could at least be profoundly affected or profoundly confused maybe, because Devo were dangerously close to the edge of truth, they were radical and crazed and they let you know there was something real there that you couldn't help but evaluate.

Now: You walk up to the Starwood. "Welcome Warner Bros.

Records." Fuck you. It's an "event." Heavy scalping. You're crushed inside and treated like KGB hit men. Appropriate. The place is oversold by about 40%. Beers are two bucks. You're forced to sit through two throwaway novelty acts before the Big Appearance. You wonder . . . is Devo gonna be more of the same? No, but . . .

THE FAMOUS FILMS. Silly, weird, fun, fairly significant, well made. A gimmick, yes. But it works.

THE SHOW. Make no mistake, Devo is **still** one dippy dynamo on stage. You could listen to the album and think: quirky, arty, absurd, a little thin. Songs not bad, but a one-joke act. But believe it, the **noise** and the **presence** make **all** the difference. Not that most of the audience would be able to tell, because unless you were right next to one of those big speakers letting those guitars make your ears bleed like they should, you might as well have been listening under water; the cattle-car of bodies soaked it all up.

But just look up from your feed trough and you can see these guys have got some pretty inspired moves, from the mock-futuristic uniforms and glasses to the jackass synchrosteps and cheers. Sheer 14-year-old gym class, ingenious moments of anti-style.

Still . . . definitely diminished. Did someone strain the Devo brains through one of those Dolby machines Eno hates so much? No highs, less hiss. There is less spectrum here. Fewer chances are being taken. But the music is moving along real well, and everything's on cue. Toes are tapping, heads are nodding, drinks

are sipped . . . if it were not for those bozo suits, is it possible we might feel the urge to . . . boogie??

Ah-ha . . .! Get it? Sure, those clever little spuds had it all planned . . . **that's** what they meant by the concept of De-evolution. You start real bizarre and strange and thought-provoking, and instead of **developing** your original concepts, you go **backwards**. These boys will have medium-length hair, complete wardrobes from Sears, and a song repertoire of top-40 and bar band standards within two years, I'm taking bets on it. But their audience, behind the times as audiences always are (witness Bowie's), will still be wearing yellow plastic suits and pinhead wigs. Performer and audience will have **switched places!** De-evolution! What an art project!

The audience filed out of the club calmly to return to their cars, and were surprised to find the entire block sealed off and half the Los Angeles Police Department waiting, armed to the teeth and ready for "Riot Control." The officers stood there or crouched behind black-and-whites, their mouths opened slightly, as if asking the dual questions: "Are we not men?" and "Banana?"

—Greg Burk

Captain Beefheart

Roxy, L.A. October 27

At the Roxy you have to be aware of your responsibilities, check over your shoulder every few minutes to see if you're sophisticated enough, careful **how** you order that drink, compadre. But this wasn't a suave trendy night or a MOR jazz night, the magazine lifestyle color Xeroxes a little sparser than usual; still you can't blame Beefheart for being a little uncomfortable. It's his nature to be incompatible.

Beefheart had fans there who were aware he is not a Halloween freak act or a sophomoric gag, but rather a truly inspired poet and a revolutionary musical mind, even if he is from Lancaster. He's been confusing people for 12 years or so of recorded history; this is about his fifth comeback, but he never really left, and he's still challenging people and they still can't take it. Hell, people are less willing than ever to part with their preconceptions of what music is.

THE MS-20 Above and Beyond.

TWO VOLTAGE CONTROLLED FILTERS

Low-pass and high-pass for extended control of the entire frequency spectrum. Each filter features continuously variable resonance control: flat to self-oscillating.

ENVELOPE GENERATOR 1

Separate AR envelope generator with Variable Delay Control.

5-PART ENVELOPE GENERATOR

Features variable ADSR controls plus unique Variable Hold Control.

ADVANCED APPLICATION PATCH PANEL

The extensive complement of control voltage inputs/outputs expands your creative possibilities by creating new combinations of the MS-20 modules (such as interfacing with external synthesizers, sequencers, etc. separately or in conjunction with the MS-20's internal capabilities).

TWO VOLTAGE CONTROLLED OSCILLATORS

Each with 10-octave range. Selectable, switchable waveforms include: Triangle, Sawtooth, Variable Pulse Width (50%-0%), White Noise, and pre-patched Ring Modulator.

PROGRAMMABLE SECOND VCA

For controlling modulation depth, sample and hold, expression, etc.

PROGRAMMABLE SAMPLE AND HOLD

For "random" or "stepped" patterns.

EXTERNAL SIGNAL PROCESSOR MODULE

Contains advanced envelope and pitch follower, allowing any external instrument to actually "play" the MS-20. Module consists of pre-amp, variable bandpass filter, pitch-to-voltage converter, envelope-to-voltage converter, and variable threshold trigger detector. Outputs include amplified/filtered signals, pitch control voltage, volume control voltage and trigger output.

PROGRAMMABLE CONTROL WHEEL AND MOMENTARY SWITCH

Can be programmed to vary pitch, cut-off frequency, VCA gain, modulation, sample and hold, etc.

MODULATION GENERATOR

Features continuously variable waveforms: Triangle-Sawtooth; Rectangular-Pulse.

PINK AND WHITE NOISE GENERATOR OUTPUTS

For both audio and control voltage sources.

PROGRAMMABLE, MIXABLE FREQUENCY AND CUTOFF FREQUENCY MODULATION CONTROLS

When Korg set out to create the new MS-20 synthesizer, the idea was to build a professional, fully variable instrument for the serious synthesist that would be a cut above the rest.

Korg built in two VCO's, two VCF's, two VCA's, two EG's, an MG(LFO), a sample and hold circuit, extra noise generators and much more. (We're showing you the essential controls of the MS-20 so you can compare it, feature-for-feature, with anything on the market.)

If you're satisfied that the MS-20 compares favorably even to synthesizers cost-

ing far more (there's really nothing like the MS-20 in its price range), then consider what makes the MS-20 truly incomparable!

The MS-20 contains a built-in External Signal Processor module that lets any external instrument actually "play" the synthesizer! (To purchase this feature separately, you'd have to pay more than the entire purchase price of the MS-20.)

Considered solely as a keyboard synthesizer, the MS-20 stands above all the competition. But, with its ESP module, Korg has taken the MS-20 a quantum step beyond.

THE MS-SERIES

KORG

Puts Synthesizers within reach.

Unicord Division of Gulf & Western Manufacturing Company, 75 Frost Street, Westbury, N.Y. 11590

SUBSCRIBE to POLYPHONY^{T.M.}

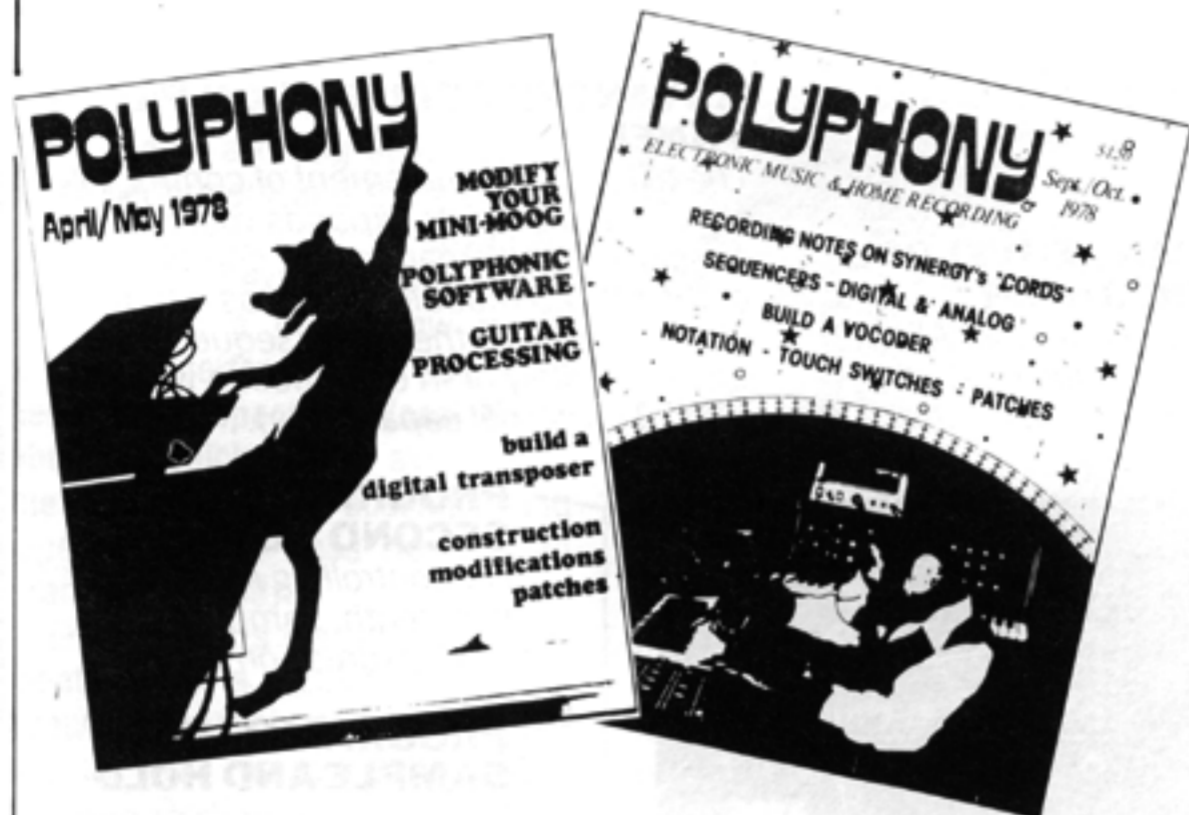

POLYPHONY: po·lyph·o·ny, po·lif'ō·nē

(Gr. polyphonia) Consisting of or having many voices or sounds. (Mus.) having two or more voices or parts, each with an independent melody, but all harmonizing.

Many voices, those who design, experiment, perform and record with electronic music equipment, combined and harmonizing to bring you a comprehensive publication covering all aspects of electronic music and home recording.

Now published bi-monthly, each issue includes original circuit designs, modifications, expanded applications and custom equipment design for a variety of electronic music equipment; electronic and music theory, recording techniques, patch charts for synthesizer and programming for digital synthesis equipment.

Upcoming issues will feature regular columns on: Electronic Composition by David Ernst, Home Recording by Craig Anderton, Experimenter's Circuits by Gary Bannister, Software by John S. Simonton, Jr. and more.

Join the growing list of subscribers who find that Polyphony is the source of the latest developments in electronic music. Subscribe to Polyphony, the creative person's guide to new ideas in electronic music.

Subscription rates:

Mailed in the USA \$8.00/year (6 issues)
 Mailed to Canada or Mexico ... \$9.00/year (6 issues)
 International Subscription \$10.00/year (6 issues)

POLYPHONY, P. O. BOX 20305, Oklahoma City, OK 73156

ENTER MY ONE YEAR SUBSCRIPTION TO POLYPHONY
 (\$ _____ enclosed)

Name: _____

Address: _____

City: _____ State: _____ Zip: _____

POLYPHONY

Circulation Dept., P. O. BOX 20305, Oklahoma City, OK 73156

PERFORMANCE

The latest Magic Band is just fine, sounding enough like the old one to let you know who's responsible for creating the basis of the Chinese blues sound, but still distinct, particularly with the addition of synthesizer and trombone. The Captain himself is looking professional these days in bulky clothes, reading glasses and mustache.

The problem is that Beefheart does not attack. He should take an audience by the neck and **shake them around**, but he isn't taking that last step that would really involve them. But then, why bother? Folks would just get scared.

—White Collar

Terry Riley: In C

**Second Second Story Series
 Larchmont Center for
 Yoga, L.A.
 May 30 1978**

Larchmont Village is a sleepy little community just to the south of old Hollywood, along the lines of a small-scale Beverly Hills: quiet and conservative. However, on weekend evenings during the spring, the area

became the center for some of the most interesting music in L.A.: punk rock on alternate Fridays, and through April and May, contemporary music at the unusual venue of the second floor of The Larchmont Center for Yoga. Sponsored jointly by the latter and the Independent Composers' Association, a group of eleven young Southern California composers, "The Second Second Story Series" consisted of four concerts, largely highlighting works by members of the ICA, but culminating in a performance of Terry Riley's **In C**, led by the composer himself.

Composed in San Francisco in 1964 when Riley was 29, **In C** has become one of the seminal works of the twentieth century, influencing all areas of music, but in particular looking forward to Riley's later preoccupations with North Indian raga music. The work consists of a pulse of even octave eighth notes pounded throughout on the top two c notes of a keyboard. Overlaying this, each member of the orchestra plays the 53 short figures of the score in sync with the pulse, moving consecutively from 1 to 53. The musician is completely free as to where he places his downbeats, and as to how often and how long he pauses between figures. The piece ends

Synapse



**Peterson
 Synthesizer
 Rentals & Repair**

9111 La Luna Ave.
 Fountain Valley, Calif. 92708

1. We are Factory Authorized Service Center for: A.R.P., KORG, MOOG, & YAMAHA
2. We rent Synthesizers, Electric Pianos, Mellotrons, Mix Boards, Tape Recorders (4 Track), Special Effects Devices and Amplifiers. Ask for our Rental Price List.
3. We specialize in Custom Modifications and Design. Ask for our Modification List if you can't think of your own.
4. We give FREE consulting & estimates.

VANCE PETERSON

OWNER — ENGINEER

Serving Southern California
 (714) 847-2301 (Evenings)

when all players finish figure 53.

This particular performance was something of a revelation. The excellence of the musicianship was aided by the receptive condition of the audience, our sensual perception having been heightened by the incredibly hot evening and the absence of air conditioning in the hall. Most people were beginning to feel groggy by the beginning of **In C**, and the perpetual pounding rhythm of the pulse and the repetitive overlays of the 53 figures produced an intense experience: as if being pounded into submission all the more effectively to appreciate the nuances of the orchestration. One's mind drifted into a dream-like state for long periods, overwhelmed by the totality of the piece, while at other times one could concentrate on the rhythm or on each individual instrument. **In C** is not an electronic piece, yet it somehow seems electronic, conjuring up the electronic pulses of the German sequencer-dominated music of Hoenig, Schulze and Tangerine Dream.

The first half of the concert consisted of three short works that, in the case of the first two, sounded very interesting in theory, but like most conceptual pieces, were some-

what arid in performance. Carey Lovelace's **Odes** counterpointed four instrumentalists with four speakers who recited three poems in a fragmented, repetitive form, to create an "ambient" total that was at once a whole and a series of fragments. It was not altogether successful, although Scott Fraser produced some interesting electronic distortions on guitar, and one found oneself concentrating on him rather than the piece as a whole.

Dave Ocker's **Backward, Looking, Forward (Book 11)** consisted of six short pieces for three clarinets, three percussionists and piano, and was rather hollow, although producing occasional interesting crescendos. In totality, the piece was too dryly academic in its juxtapositions, although not unpleasant for all that.

The best of the three was Lois Vierk's **Kana** for tenors and basses, a set of three short pieces sung a cappella, consisting of rising and falling sound textures, both interacting and counterpointing to produce alternately flowing and rhythmic patterns. It was a refreshing end to the first half of the evening, all the more welcome for its humor, and a tasty hors d'oeuvre for the entrée to follow.

—Colin Gardner

Synapse

Did you know that The Rolling Stones, Van Halen, Steve Miller, Mahogany Rush, Peter Gabriel, Fleetwood Mac, Black Sabbath, Johnny Guitar Watson, Stephen Stills, 5th Dimension, Boston, Bay City Rollers, AC/DC, Janis Ian, Bob Weir, Chic, America, Earth Wind and Fire, Bob Seder, Kiss, Thin Lizzy, Beach Boys, Nektar, Taste of Honey, Aerosmith, Elvin Bishop, Billy Joel, Bob Welch, Randy Bachman, Pat Travers, Foreigner, Derringer, Heart, Foghat, Mandré, LTD, Styx, Kansas, Heatwave, Rufus, and Yes all use THE

SCHAFFER-VEGA DIVERSITY SYSTEM!?

Better sound than w/cord.

• No Tuning!
• Protected Frequencies
• No Fades or Dropouts!

NEW! Schaffer B+T non-diversity system under \$2000!

Hooks right onto GUITAR STRAP!!

OFFBOARD

- 5 preset intervals
- Guitar to Harmonizer to Amplifier mix!
- Footboard to control all functions

Wow! This is easy!!

Eventide

half or all top studio rely on Eventide!

HARMONIZER

- 2 Delay Outputs
- Pitch Change
- Automat. Harmony

STUDIO DELAY LINE

- Top of Line
- Up to 638ms Delay
- 5 Indep. Outputs
- Up to 2 pitch changers.

INSTANT FLANGER

- Cleanest!

WIRELESS!

- HEADPHONES FOR STUDIO
- DUPLEX INTERCOMS

YACKETY YAK YAK

AND MUCH MORE!

THE KEN SCHAFFER GROUP INC.
10 East 49th Street, New York, N.Y. 10017 • (212) 371-2335

ALL EARS RECORDS PRESENTS "A CONTEMPORARY CLASSIC"



FEATURING
AN ORCHESTRA OF 38 TOP MUSICIANS
ROCK • JAZZ • CLASSICAL • AVANT-GARDE

INCLUDING

EDDIE JOBSON AND RUTH UNDERWOOD

LIMITED EDITION
ON CRYSTAL VINYL

MUSIC TO MATCH
YOUR INTELLIGENCE



ALL EARS RECORDS PBR INTERNATIONAL
7033 SUNSET BLVD., HOLLYWOOD, CALIFORNIA, 90028

JASUN MARTZ — THE NEOTERIC ORCHESTRA 'THE PILLORY' AE 11480

Synapse has received more requests to publish an interview with Brian Eno than any other artist. It's easy to understand when one considers that he has worked with David Bowie, John Cage, Roxy Music, Robert Fripp, Cluster, 801 Live, Devo, Talking Heads, Nico, John Cale, Kevin Ayers, and Mike Oldfield, among others. What kind of a personality does it take to collaborate with such diversity?

by Kurt Loder

Kurt Loder: In your various recording projects over the past five years with David Bowie, Robert Fripp, Phil Manzanera, John Cale, Ultravox, John Cage, and, most recently, Talking Heads and Devo, you've raised the art of collaboration to a whole new level of creative endeavor. What particular qualities do you look for in a potential collaborator?

Brian Eno: Sometimes I think any collaboration is worthwhile, because if it isn't a promising one, then I have to work all the harder to get something that interests me personally out of it. This is how I work with film scores. If I've got the time, I'll accept any film score, as long as the director isn't a creep who I just don't get on with. I'll accept any film job quite independent of what I feel about the film, because it's an excuse to make some music. In a way, if I'm not sympathetic to the film it's even more interesting, because I've got a constraint that's bound to push something new out of me. So one theory of collaboration is that I'll do anything. The other theory of collaboration says, in fact, there are some people who are much more interesting to work with than others. So these two things vie with each other.

The collaborations I enjoy — in fact the ones you mentioned, and especially the recent two I've had with Talking Heads and Devo, arise from a sense that the other party of the collaboration has a set of skills that, in combination with my set of skills, will produce something novel.

Synapse: What was there about the first Talking Heads LP that intrigued you enough to want to produce their second one?

Eno: Well, first of all I found it very, very attractive material, full of potential, and certainly manifesting an intelligence that stood behind the music. And it struck me that the music was all the product of some very active brains that were constructing music in a kind of conceptual way. It seemed to me — and this was confirmed by later experience — that these people were making experiments. They were thinking, "What would happen if we did this? And this? Oh, yeah. So what happens if we now do this with it?" And when I talked to David (Byrne) subsequently, indeed this is what they do. He says that some of their songs have arisen from a purely intellectual basis. And my own work arises from similar ideas, from really just thinking, "This might be a good idea. What

ENO

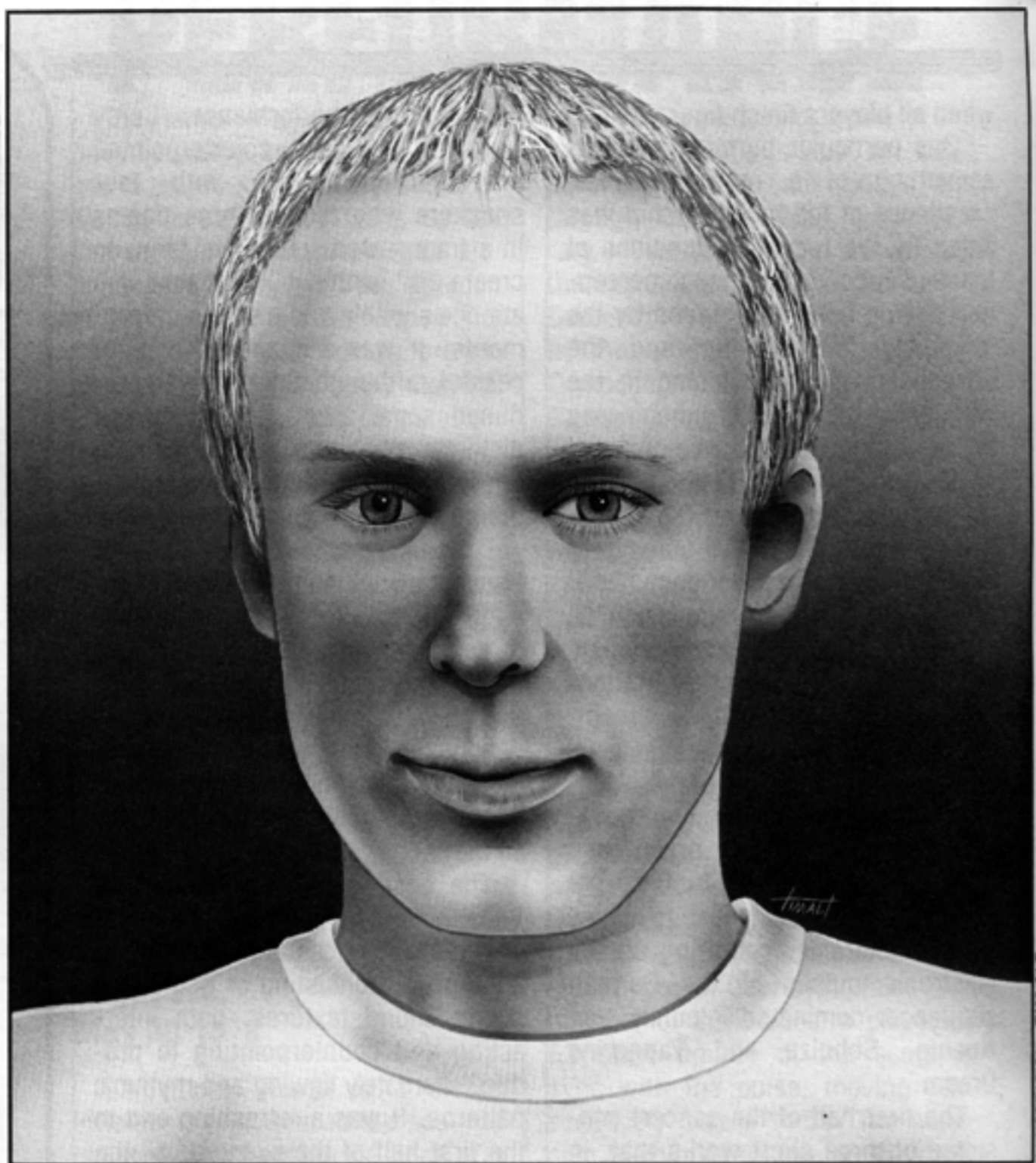

ILLUSTRATION: TIM ALTY

would that sound like?" rather than from the way people *think* songs are written. People think that you sit at home and you have a melody and the chord sequence in mind, and then you think, "Well, what instruments would be good for this?" You know, that kind of idea of having a *goal*, which you then build towards. I don't think anyone works like that, or very rarely. Sometimes there will be a melody at the beginning, or a particular rhythmic configuration, but generally there's a sense of, "Well, I'm going to set this process in motion. Where will it lead me? And furthermore, do I like where it leads me?" Because if you don't, you abandon it; you start again.

Synapse: How long do you give an idea to work out?

Eno: That's an interesting question, because it really depends on your confidence level at the time. There are some days when my confidence level is so high that I can make anything work. There are other days when it just won't work like that. It really depends sheerly on confidence and energy. Particularly if you work without a group, as I do, you really need a lot of energy to push something through those first stages, where it's just a rhythm box going "bump-titta," and a piano going "dum, dum, dum." I mean, that doesn't sound terribly interesting, so maintaining the conviction to keep going, in the hope, or in the trust that it's going to turn into something, does require a lot of application. And some days I just don't have that.

With the Talking Heads, all the material on the album was pre-written, but some of it got changed in the studio. Some of it got changed quite a lot. Like in certain sections I would say, "Now, look, this section is going to be interesting, I can tell; why don't you extend it now? If it doesn't turn out to be interesting, we can easily edit it back down again. But let's make it longer now; let's see. I just get the feeling that something's going to happen

here." And we did that. On other occasions, a number that worked very well live didn't make it in that form in the studio. So we would chop it about, sections would come out, the thing would be edited to a much more compact form. And in fact, one of the differences, I think, between this and the last record is that there's a real conciseness about the ideas, and there's a very high rate of ideas per minute, much higher than the other record.

Synapse: Did you utilize the studio more? Is there more synthetic percussion, for example?

Eno: In fact, there's not synthetic percussion as such, but there are quite a few cases where the drums are treated and, "electronified," if you like. Because the way I was set up was such that I had my synthesizer directly linked with the control desk (mixing board), so that as they were playing the basic tracks, I could feed any instrument — or all instruments, if I wanted to, but I never did that — through my system, and start playing with the sound of it. And on some tracks, this was quite decisive. It really gave a character to the track, which then modified how they worked on it. So there was a real interaction in that sense. Other tracks I left pretty much alone, because as far as I was concerned they'd already extended the things quite a long way.

Synapse: What kind of synthesizer setup do you use in the studio?

Eno: If you work in different studios, you find that they all have a few bits and pieces around. And I always find it much more interesting to be confronted with their bits and pieces, which are probably not what I would have chosen, than to keep carrying my own stack of things. I'm not interested in developing a body of technique that works. So I carry just one thing with me, which is this little synthesizer that fits into a suitcase, which is a very idiosyncratic machine. It's made by EMS.

I've had it for a long time, and I've never had it serviced, so it's quite quirky. It's rather unpredictable, and it does very interesting things. So I take that around, because it still surprises me.

Synapse: *What was your approach to Devo? Aren't they almost entirely the opposite of a group like Talking Heads?*

Eno: They're another polarity to Talking Heads on one continuum. But in another sense they're very close to one another. And that sense is, again, this experimental feeling of "What would happen if . . . ?" I get the feeling with both of them that there's a kind of intellectual rigor about what they're doing. When you are working on a piece of music, you are constantly presented with easy ways out, ways you could get it finished easily, just get it out of the way. Put some strings on, you know, that kind of thing. That's the most hackneyed approach to the problem, but there are more sophisticated easy ways out. Now, it strikes me that both of those bands generally don't take them. They both have an idea and extend it as far as it'll go, until it collapses. If it somehow still stays intact after the quite rigorous attack they give it, it's a worthwhile idea. I see the roots of Talking Heads being primarily — drawn from funk and that kind of music, which they've added a layer to; so you still have this kind of slow bouncing thing underneath, but on the top you have these rhythm guitars that are very, very choppy and precise and accurate. That particular mixture is something new, I think. With Devo, you have something that makes your body move in a new way. It really does. If you listen to Devo's music, you suddenly find you're doing this (he leaps about robotically). It's really . . . it has this stiffening effect on you.

Synapse: *In their case, it seems to be a complete lifestyle.*

Eno: Yes, well, in fact all the best approaches are lifestyles, actually. That's what you find. With Devo, Talking Heads, and with me, what all of us do is to work with the way we are; the way we live and how we behave socially and so on; what our politics are.

Synapse: *Speaking of politics, weren't you heavily influenced by Cornelius Cardew, the British avant-garde composer who became a Maoist?*

Eno: Yes. I am an admirer, but not of his recent work. My personal opinion is that the Maoist thing for him is a very big mistake, and it significantly reduced his music. I think it nearly always does, because when you become political, what you attempt to do is codify a set of perceptions into easily handleable chunks, mainly language. Now, nearly always the most interesting things that an artist does are not defensible on that level. When you work, you find you're suddenly in a position where you're exposed; you can't defend what you're doing. You just have to say, "For some reason this is interesting to me, I don't know why. Maybe I will in a year's time." And usually, sometime later, you do know why that was interesting. But at the time, you've extended yourself beyond the territory that the intellect can account for.

Now, normally, when people become politically conscious in the way that Cardew did, they forbid themselves that activity. They say, "The job of an artist is to radicalize society," for example, and they say, "How do you do that?" And so then they start thinking, "Well, you do it by this and this and this" — and suddenly, the music becomes like an advertisement for a doctrine. Furthermore, a doctrine nearly always lags behind the real implications of the music that they were doing previously.

Cardew is a very interesting case in point. He

wrote a piece called "The Great Learning," which was seven separate pieces, and one of them — they're called "Paragraphs" — one of them was called "Paragraph 7," and for me it's really one of the most interesting pieces of modern music ever written. It's for singers with any degree of training. I've staged a few performances of it, and I wrote a long essay about the piece in *Studio International*. His score is extremely simple; there's no notation, and there are very few instructions. Somehow or other, this piece always comes out sounding very beautiful, and very similar from one performance to the next. And I started thinking, how can this be? He hasn't specified anything, and yet the piece always comes out the same — when I say the same, I mean the overall effect of it is identical in each performance. The constraints are very few; it's not hard to form. You can almost say you do what you like, but you don't quite. I started trying to investigate why this piece worked as it did, because there are many other pieces of modern music that try to do the same thing and fail. The performances are all totally different, and some of them are shit, and people don't enjoy them and people don't enjoy *listening* to them. The thing about this Cardew piece is that it's beautiful to do and lovely to listen to. So I thought, what is it? How has he constructed this thing so that it regulates itself in this way? Because basically that's what it does: there's a whole system of automatic regulators that come into being during a performance of this piece. They're not chosen, they just happen. For example, it has a paragraph from Confucious, and the paragraph is divided into 18 lines, I believe. Some of them are just one word long, and some of them are two or three words long. Beside each line is a little instruction that says, "Sing 8F3," for example. That instruction means, sing this line eight times; any three of those times, sing it loud. The ancillary instructions say, "Sing any note that you can hear." So that means when you move to a new line, your choice of notes is governed by the available notes in the environment, the notes other people are singing. So you choose a note that you can hear. Well, typically, there are a lot of them, so you've got a very wide choice. And it also says, "Sing the line each time for the length of a breath." So if the word is just "if," you go, "iiiiiiif," right? Eight times, and three of them loud. That's all the instructions and somehow or other, this piece always sounds the same. When you hear three or four performances, you start to get real puzzled by this. There are a large number of reasons for this, and cybernetics and systems theory are actually the mechanisms by which you can explain this piece. Because it has very strong parallels with high biological systems, which again aren't governed by external controls.

How do systems like this keep themselves intact, how do they respond to interference, and how do they maintain their identity? In fact, all systems of that nature are what's called autopoietic, which means they serve to maintain their own identity. With the Cardew piece, just take the instruction, "Sing any note you can hear." Now, a number of things can happen given that instruction. First of all, it's normally performed with a lot of people, therefore it's in a large space. In any large space, you always get an acoustic resonance building up. You know how in your bathroom you'll find one note, if you're singing is very, very loud? That's the resonant frequency of that room. Now, in any large space there'll be a resonant frequency, and if you have a lot people singing, the probability is that any note hitting that frequency will be slightly louder than all the other notes. So the probability is reinforced that, given the instruc-

tion "Sing any note that you can hear," the chances are slightly in favor of your singing that one. So what happens when this piece begins is, it very quickly settles down 'round a drone, and the drone is the resonant frequency of the room. So that's one thing that happens. It's not specified in the score. Cardew probably didn't even know that it was going to happen.

The second thing that happens is that, typically, it's done with singers of all different types of skills; that means you sometimes have people who are tone deaf. When they get the instructions to, "Sing any note you can hear," try as they might, they fail. So they introduce new notes into the piece. If the singers were all perfect, the piece could only diminish in terms of the number of notes that were available as logical. They would all finish their lines at different times. So, say there are 20 singers. Number 19 finishes. He's got a choice of 19 notes to sing from, so he chooses one of them. Then number 18 finishes; he's got a choice of only 18 notes . . . it's bound to get smaller. But by the factor that people don't always sing the right note, or they sometimes sing an octave too high, or a fifth too high, or something like that, or they adjust to their own register — again, new notes are introduced. So the piece has a kind of vacillating range and number of notes.

Synapse: *Sounds like the choral montage effects of composers like Penderecki and Ligeti — although they're of course composing toward their effects.*

Eno: The old method of composing is exactly that — you specify the result you want, and then you present a number of exact instructions to get to there. Which is like any old social system where, by systems of laws and constraints, you attempt to specify behavior. Now the Cardew piece, for me, is a radical thing socially, because he doesn't do all that, and yet it happens. The behavior remains governed. I think political systems are all doing what the old composers were doing. They're all saying, "What kind of society do we want?" If you give the most generous interpretation, they're saying that. Then they say, "Alright, so let's constrain this behavior here and let's encourage this here and blah, blah, blah." And they're all trying to govern by rote a highly complex system. You don't need to do that, that's the thing. The Cardew piece, for me, proved that, under the right circumstances, you can set the system up so that it goes there itself. In fact, Stafford Beer, the cybernetician, has a very good sentence in one of his books. He says, instead of trying to specify in full detail, you specify only somewhat; you then ride on the dynamics of the system in the direction you want to go. There are certain organic regulators; you don't have to come up with them, you just have to let them operate. All of the current political systems seem obsessed with this old idea that the job of government is to constrain the natural course of events. Now, I can see quite the opposite — the job of government being to take advantage of the natural course of events. For example, if you look at two ways of generating energy, one way is where you rip holes in the earth and pull coal out and leave a great big mess and make a lot of smoke; and the other way is to find a waterfall and stick a water wheel on it. So all you do is, in fact, interrupt an entropic process — there it is, it's carrying on, it'll still carry on. You haven't taken anything from anything. All you've done is intervene in a procedure that's already happening, and tapped something off.

Synapse: *Of course, water wheels are hardly the solution to our energy problems on a national scale, are they?*

Eno: The scale is certainly the biggest consideration in this. I suppose the main reason I'm interested in cybernetics is that it does deal in terms of those very complex situations. Cybernetics, under some definitions, is the science of complex systems. So it deals with systems that are probabilistic rather than deterministic. It says that, "This is a very complex system; all we know is that it's likely to give this class of results" — this *class* of results, not "this particular one." Now, in that sense, it's an inexact science, and it's the first real science that is inexact that actually can do something. As far as I'm concerned, those other ones, like sociology and psychology are very inexact and they really don't seem to work. In Brian McCulloch's book, *Embodiments of Mind*, he says a very interesting thing. He says, at the end of a series of psychological sessions, the psychologist will say, "The treatment is finished." And McCulloch says, "I've never actually heard one of them say, 'The patient is cured.'"

The thing is, we can't accurately predict. One of the central ideas of cybernetics is that the system itself will inevitably produce a certain class of results. That's what it does. That's in the nature of the system. And one of the major results is that it will prolong its own existence. So two things are operating: first of all, the system is seeking to prolong its own existence; and secondly, the system is degenerating. It always is; information is always passing out, we're getting older, a process of decay is always at work. So those two things are happening. Again, most of the political systems don't recognize this. They say, "There's this institution that does *this*," and when something different is required, there's a huge effort to maneuver that institution to do the new thing. But it won't. It's in the nature of systems to do one thing, and not something else. The structure of a system governs its behavior. That's how simple it is for me. And if you want to change the behavior, you have to change the structure.

We both share a vast civil service, a bureaucracy that hasn't realized this point, and which is *highly* autopoietic. I mean, most of its behavior is an attempt to prolong its own identity, and to produce more of itself. I don't know which country has it the worst. It's certainly bad in England.

Synapse: Can these systems be changed, then? Are you interested in trying to change them?

Eno: I'm not a proselytizer or an evangelist of any kind, because I don't think that's how change



PHOTOS: GARY KENTON

happens. I think that serious political change is always personal. All that could happen is that you might happen to say something to someone just at the point where they're ready to change. That's fine; you might be the person who says that to them. For that change to be real, and to be properly realized, they *must* have reached that point. You might just crystalize it for them, you might clinch it. But for me, the idea of actually convincing someone doesn't work. If the necessity for a change isn't already within them, they won't change. If the necessity for change isn't there, that means they don't see the same world as you. And so the procedure of introducing them to the world is quite different from evangelizing about it, and it's one of the results which you can't predict. They might come out with a system much better than yours, actually. Or quite different.

For me this Cardew piece was a radical lesson in how a little society could be organized — a micro-society — or how it organizes itself. Every contribution was valuable. The contribution of the tone-deaf singer — the system was constructed to use that as well. I really don't know another piece of music that is so extraordinary as "Paragraph 7" in those senses. It really is a unique piece. I only wish that he'd gone on with doing more of that.

Synapse: How did your collaborations with Bowie come about?

Eno: What was happening to him — what happens to everyone — was that a chain of ideas was running out. When that happens, you can easily keep going on, rehashing them, if you want to. Or else you can be brave enough to say, "Look, they're just not doing any more for me, I've got to start doing something new." Now, for him, I think that's quite a risky thing to do. It's not for me, because I've sort of set myself up as someone who does that kind of thing. It's almost expected. And I've been careful to guard that position, in a way, maintaining my mobility. But I think two things were happening: first of all, a chain of working approaches was running out for him, and he was beginning to sense that another one might be starting. He liked *Another Green World* a lot. He

saw in that an approach that he liked, I guess. Similarly, I heard *Station to Station* and thought that was a great album. And I thought, in the same way, "There's ideas in that I'm gonna nick." And so the coming-together was fairly natural. Mutually interesting.

Synapse: So Bowie influenced you in certain ways?

Eno: Yes he did.

Synapse: Some of the songs on *Before and After Science* especially on the first side, sound a lot more percussive than your usual material, much in the manner of Bowie's *Young Americans* and *Station to Station*

Eno: Well, I used to have this little badge which said, "Join the Fight Against Funk." Because in 1974 or '75, I absolutely despised funky music. I just thought it was everything I didn't want in music. And suddenly, I found myself taking quite the contrary position, and I had to chuck my little badge away, because it wasn't true anymore. And I suddenly found that, partly because of what he was doing and one or two other things — mostly Parliament and Bootsy and those people — I suddenly realized that if you took this a little bit further, it became something very extreme and interesting. And Bowie did; it was like "grand funk." It was so exaggerated that it became a new form, it wasn't just schlocky gloss. And also he left all his rough edges in. He always does.

Synapse: Given the curious course your career has taken, I wonder what sort of music you grew up listening to?

Eno: I had a very interesting selection of music. I lived in a little town in Suffolk which was within five miles of two very, very large American air bases, and there were lots of cafes in the town which all carried American records, as well as English ones — even quite obscure American records. Then there were the PX stores. My sister used to be a "Yankee basher" in Suffolk; that meant she went out with one or two Americans, which was terribly frowned upon by the locals. But it meant that she also used to go to the PX there and come back with all these really very interesting records that

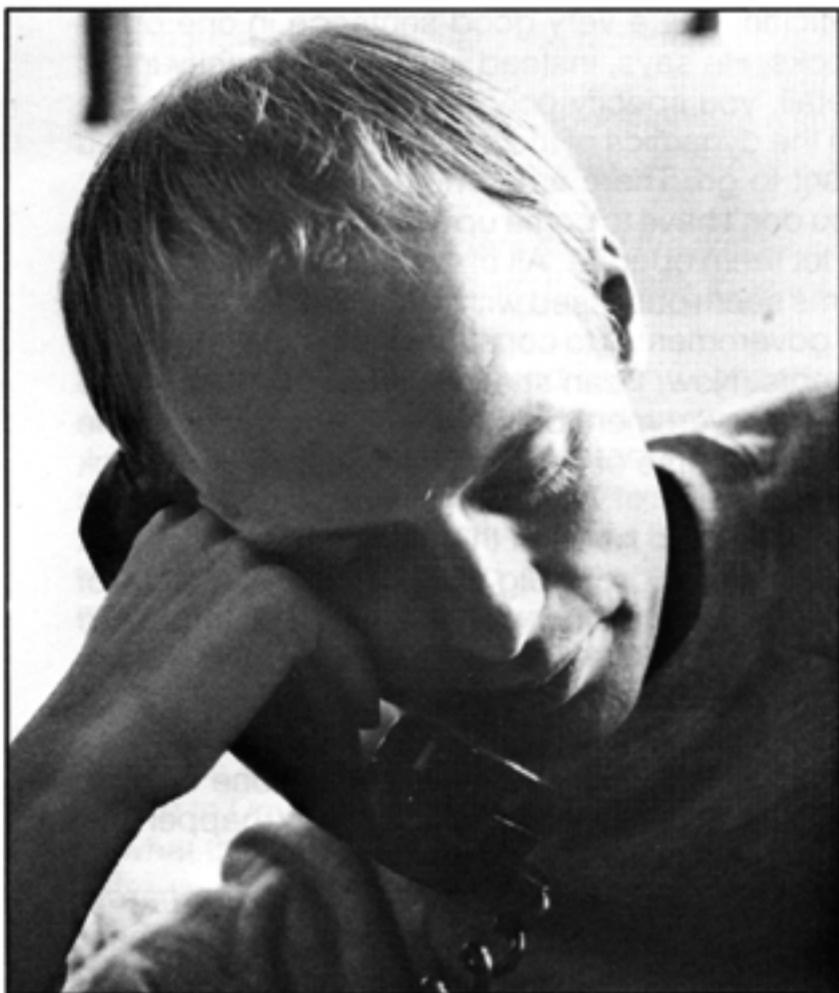

“I’m not a proselytizer or an evangelist of any kind, because I don’t think that’s how change happens. I think that serious political change is always personal.”

you never heard in England otherwise. They never were on the radio. So I grew up with a very transatlantic background in music, and I was interested in music very early. We had a player piano, one of those things that you pedal, and I used to absolutely love that. I played that all the time. All we had were like old hymns, like “Jerusalem” and so on, which I thought were beautiful. And I think that the kind of melancholy quality of those is something that’s actually persisted in anything I’ve done since.

The thing about all this American stuff was that I had no idea what its antecedents were. It was just mystery music to me. I’d hear like “Chicken Necks,” by Don and Juan, or “Get a Job,” by the Silhouettes, and I’d think, “This is just weird music.” Nothing at all in England was like that. So it was like space music, and I found that I was very excited by music that was as strange as that. Because you must remember, English music at that time was *really* boring: Cliff Richard and Tommy Steele and . . . just a lot of very poor imitations of the larger American stars.

The other thing was that I had an uncle — he wasn’t really an uncle, he was just someone that we called an uncle — and he was really into big band jazz; Jack Teagarden and that kind of thing. At one time he didn’t have anywhere to live and dumped this huge pile of albums on us. My parents didn’t like them at all, but I used to get up early in the morning and listen to these records, which, again, were totally mysterious to me. And I did it unselfconsciously — I wasn’t thinking, “This is the music I listen to.” I was just interested in it, for some reason. I didn’t know where it came from or what jazz was.

Synapse: What first got you interested in music as art?

Eno: At the age of 11, I had this uncle — a real uncle this time — who’s like the eccentric of the family, very nice man, and he had spent some years in India. So he had these kind of strange Indian ideas about things. He’s quite eccentric, very strange, always trying out weird experiments at home, building ways of distilling liquor and stuff like that, and taming the strangest animals, like rooks. He was very important to me, because he represented the other half, the sort of strange side of life, and he was to me like all that music was as well. And I would think, “Where’s he coming from?” as they would say now. I used to go and visit him regularly, once or twice a week, and he used to talk and introduce me to ideas. One day, he showed me this tiny book of reproductions of Piet Mondrian. And I thought, “God, these are beautiful.” They really were the best things I had ever seen. And again it was the same thing as with jazz, of suddenly jumping in, with no concept at all of what the antecedents to that were. I hadn’t really been that interested in painting before. In fact, I really can’t remember looking at pictures much before that, though I’d been so good at art in school. Which meant just copying things, really.

But this Piet Mondrian, I thought, “Boy, this is really exciting.” And at that moment, in fact, I decided, “I’m going to be a painter, that’s what I’m going to do.” On my next birthday I got a set of oil paints, and I started painting.

I had also made the other important decision that I was never going to have a job, which I made a bit earlier than the age of 11. Because my father had a very hard job, and I could just see that his life was totally this job, and that, effectively, it was killing him. He would just come home, fall into a chair and go to sleep. And then he’d get up and go to work again. He was so tired he couldn’t eat sometimes, and I thought, “I’m never going to do that.”

So with these twin ideas — I’m never going to get a job, and I’m going to be an artist — I finally left grammar school armed for the outside world. And by an extraordinary coincidence, I happened to get into a very good art school. It was very good for exactly the two years I was there, because for those two years, a group of extremely liberated teachers took that art school over and set it up as a kind of experimental teaching unit. They were really very brilliant men. Of course they were sacked at the end of the two years when their contracts expired, because the education committee was horrified, literally, by what had been going on there.

The first term was a deliberate disorientation process, which we weren’t told at the time. Projects were set up which were *extremely* difficult. And we had all gone to art school with our little boxes of paints, thinking that we’d get there and start painting nice pictures. Well, a typical project, the very first one we did, was: “Discuss visually the differences between a hot water tap and a Venetian blind.” And we all looked . . . what do you do, you know? And that was the easiest one. The others didn’t even involve making pictures, they involved building games, methods of testing people’s behavior. Very, very interesting stuff. I think three people had nervous breakdowns during the first term and left, and a number of other people left because it just wasn’t what they had hoped for. But those who stayed were very committed to this art school. It wasn’t big; there were only forty people, maybe. In its time, it was very revolutionary. They were deliberately setting up situations that they knew would give rise to expectations, or predictions, about what would happen next, and then not letting those things happen, changing it. The whole first term was based on a kind of discover-your-rules, organize-yourself, don’t-look-to-us-for-answers kind of thing — but in a way, we can also help. That’s a very different teaching proposition.

It was really at that art school that I started thinking about music, and realizing that there was a way that I could be involved in music without technical skills. The tape recorder was the first thing. The art school had got a tape recorder, because they figured somebody was going to

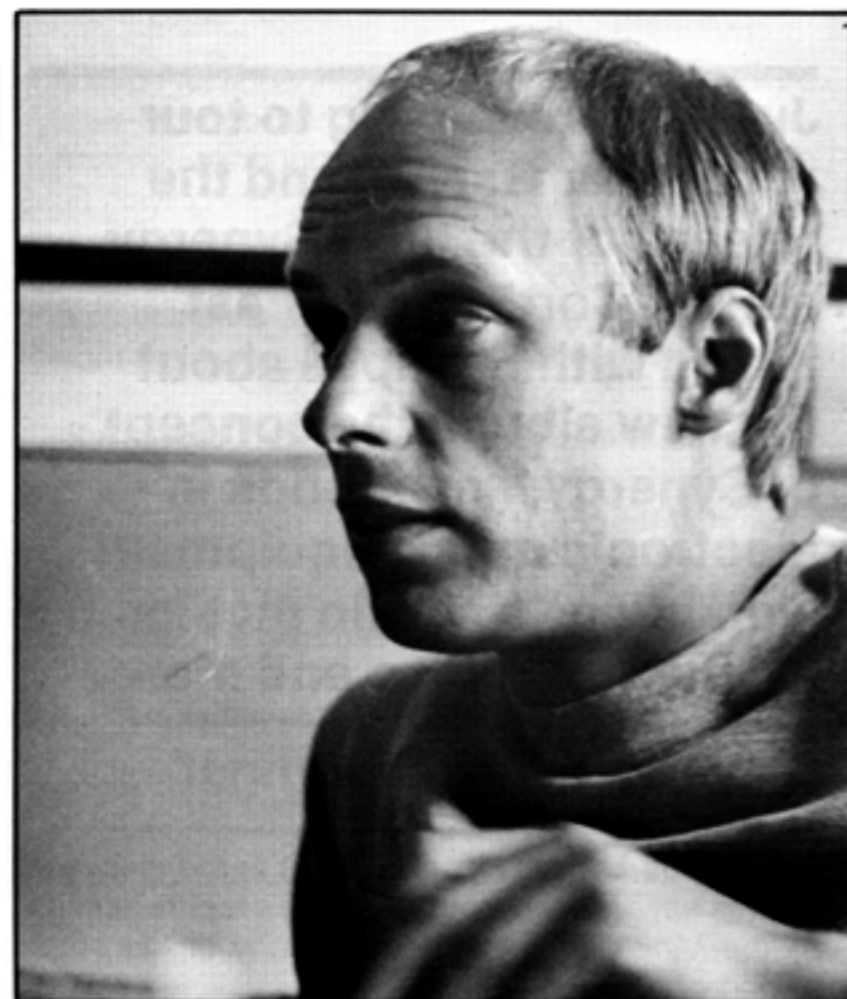

start making music. And the thing about tape that I realized very quickly is that it turns sound into a plastic art. Literally. By putting it onto plastic tape, it becomes a malleable medium. So suddenly you can disregard all the rules about real time. If you want to, you can do it over a period of days and edit it all together and get it that way. Or else you can stretch it, or slow it down, or speed it up, or you can expand it by doing things to the frequencies involved. You can remove bits from it. Tape suddenly makes all the difference. And as soon as I realized that tape made sound malleable, it became something that you could treat, like you would treat a piece of stone if you were making sculpture. Or even better, a piece of clay, or a painting, or anything. Something you could build on.

It started as almost a dilettanty thing, then gradually it started to assume more importance, because I started finding that where I was getting the most surprises was from the music, not from the painting. There weren’t any instruments; the only thing that was there was this wacked-out old out-of-tune piano, which I used to use. But mainly I used my voice as the source, and I used to build up layers of phonetic, vocal things. Not really singing, but just voice noises built up. One of my other favorite sound sources was this big metal lampshade, and it made a beautiful *bonnnnnng!* And so by recording that at different speeds I could get notes. It was a pretty slow business.

I used to perform with them (the tapes) at the art school. Because the other thing that I was into then was phonetic poetry, which was big at that time. The pure-sound-type poetry. Kurt Schwitters was one of my big heroes then.

Synapse: A fragment of Schwitters’ “Ur Sonata” turns up in “Kurt’s Rejoinder” on *Before and after Science*. How did that come about?

Eno: That recording was made in 1930, I think. It’s the only existing recording, as far as I know, of Schwitters. He’s dead. That’s his voice, but it’s just grabbed out of that recording. Somebody’s gonna sue me one day for that, I think, because in fact the BBC owned the recording. I expect someday it’ll come up in court. I was listening to the radio, and there was a program about the Dadaists, and they had this piece of Schwitters’, and they also had this other guy called Hausmann, who I used to like a lot, who was in a similar vein, with a much rougher voice than Schwitters’. And in fact that track started out with Hausmann on it, but Schwitters suited the track. 🎧

Just before leaving to tour with Peter Gabriel and the release of the third Synergy album, Cords, Larry Fast talked with Synapse about the new album, the concept of Synergy, new trends in electronic music equipment, working as a studio musician, production, video and more.

by Douglas Lynner

Douglas Lynner: *It's interesting to me that your albums have been so dominated on a technical level by the Minimoog, as opposed to any of the other myriad of choices. Why is that?*

Larry Fast: Well, it's very versatile for an awful lot of what I want to do. It's functional, and it serves as a pretty good jumping off point. It was thought out very well when it was designed and in dealing with melodic music, it just makes sense to work with it. Sometimes it's easier just to go for a sound in the simplest, most direct way, rather than sitting around patching the thing together on a larger instrument in the long run, you really don't end up with anything necessarily better sounding, and it's a longer way to get there.

Synapse: *What do you feel about the current trend in polyphonic instruments? Do you find them useful?*

Fast: They're useful in some ways. For live performance they're good, and I think they enable you to get a better grasp on a composition. If you're working on a piece that can be performed in some semblance of what it's going to sound like, then it's quite a help. But I haven't used them that much, except in cases where using something polyphonic might save a track or two.

Synapse: *What about digital synthesis?*

Fast: That, to me, is the most exciting end of the whole thing. I think the capabilities of digital synthesis will be far beyond those of the analog system. They're so much more versatile because of the non-dedicated functions inside the machinery, that the whole thing will become much more compact physically, but at the same time, much more universally applicable. You won't be limited to four function transient generators. You'll have whatever the envelope requires. You won't be restricted to the simple waveforms that are easily obtainable in analog oscillators. The sequencing and multi-track digital storage will be quite impressive. And another thing that hasn't been exploited much thus far, is the ability for internal digital signal processing, which will be a lot more sophisticated than the external signal processing being done on analog synthesizers right now. And it will be more than just filtering: complete waveform modifications that can be performed in almost real time on audio signals. All these things have been done. It's just that nobody has been able to put it all in one package yet, although a few pioneers are already on the market.

The most exciting one that I've come in contact with though, is the Bell Labs device. It's called a synthesizer, but it's still quite universal. It has the most going on, but it's also absolutely the most confusing thing in the world at this point, because it requires so much advance preparation and programming.

Synapse: *How do you think that problem of accessibility can be worked out? Certainly, digital*

technology is not something that most people understand, although they deal with it everyday.

Fast: Yeah, although you have to remember at the beginning of the whole synthesizer thing, most people were really snowed by that too. It threw a lot of people for a loop, but it also forced them to learn more about their instrument, more about the audio arts, and what was involved; and, to my way of thinking, it's much easier to see how digital technology is working. I think it makes more sense than analog which has a lot of little quirks in it — why you can't do this, and why you can't do that. I think it's going to force more of a re-education. I hope people don't stop learning now that they've gotten their analog synthesizers conquered, because it'll go way beyond that.

Synapse: *Let's talk about your albums on a holistic level. You've always gone under the name of Synergy, which has specific meanings. How does that relate to your musical concept?*

Fast: Well, there are a few ways to approach the music of Synergy. The reason I use the name is that I didn't want to get into an ego tripping solo album, former person from a band trip, who now makes his own records. I wanted the music to stand on its own, and if it meant not using my own name, that was fine.

Synergy also became a project name which I took from Buckminster Fuller. He was using it in the sense that the whole is more than the sum of its parts. That is very applicable to electronic music, and especially the multi-track work that I do, because by the time you take into account all those interacting harmonics, phase shifting, and phase co-ordination that happens between the tracks, you end up with something that sounds a good bit larger. And that's really acoustical synergy at work. A synergistic reaction.

Synapse: *On your new album, Cords, one of the big changes I noticed is that you are working with a guitar synthesist.*

Fast: Well, Peter Sobel is the guitarist. The guitar synthesizer was developed by a guy named Russ Hamm.

Synapse: *What's different about it from what's on the market these days?*

Fast: Well, what Russ did was to set up a digital simulation of the waveforms in the guitar, and he worked out a system based on creating pulses, and actually doing a real time correction on any kind of pitch errors that are in there: fundamental versus harmonic problems that create other pitch errors, and false locking. And, working it out in a digital system, it seemed to be basically a self-correcting analysis unit for pitch detection.

Synapse: *When you say self-correcting, what do you mean?*

Fast: Well, it's looking at the strings on a zero crossing by zero crossing basis, so it's constantly checking each time it's got a pitch, each time it's got one cycle; comparing it and correcting it if it seems grossly out. And it amounts to keeping it fairly well in.

Synapse: *How is the delay?*

Fast: Virtually none. It only takes about one cycle to figure out what's going on, and even on low strings it's amazingly quick. I haven't noticed any delay. Pete hasn't complained about it, and he's a really quick guitarist, classically trained. He's gone out of his way to do anything he can to fool it, and give it problems. They all glitch out at a certain point. There are certain matters of how a guitarist plays; and it requires that you don't do things like create fret noise, and that kind of thing; but there are other things that it will do that the other ones do not do particularly well. Those are things like hammer-ons, and long slides, and particularly tight string pulls — ones that are more out than across — and it's been really good on all of this. There was only one in the world, but I just talked to Russ, and now there are two. It's also very inexpensive, and uses all off the shelf components, nothing exotic.

Synapse: *Inexpensive. Could you give me an idea?*

Fast: Well, I don't have the exact figures, but I can tell you that just the front end, the pitch detection part, apparently costs about one fifth of what other manufacturers are paying in O.E.M. costs. There's really nothing in it that you couldn't go down to Radio Shack and buy.

Synapse: *That's great. Tell me, on your new album, is there any one concept uniting the music?*

Fast: No, nothing really unites it. There are musical themes that recur within the structure of the album. But when I'm working, it's not done with a lyrical or thematic concept in mind. It's wherever the music seems that it should go next. If it were up to me, I don't think I'd even be giving the songs names. I'd give them numbers.

Synapse: *Why is that?*

Fast: I just don't hear them as really anything. They are instrumental, and they are music from the purest level of music.

Synapse: *I see. What do you feel is really special about the album compared to your others?*

Fast: Well, this one is quite a bit more sophisticated than the other two because the recording technique is getting better. That's partly the result of me learning more, and partly the result of the studio becoming more sophisticated. The writing is also better; and the guitar synthesizer has lent a degree of control to some of the passages that would be quite unattainable on a keyboard without some really hairy techniques of special control, and very strange recording processes going on. And it happens more naturally so it feels as if it is part of the music. So, that's quite a bit.

Synapse: *Yes it is. A lot of studio projects you've been involved in are interesting. Certainly my favorite is the first Peter Gabriel album. I'm especially interested in some of the vocal effects on "Moribund the Burgermeister."*

Fast: Well, we did a few things where we integrated the recording and synthesis process, which is something I really like playing around with — things like using envelope followers to control oscillators on phasers and flangers. For instance, with the African drum — the kind with the rope that you squeeze to change the pitch — the envelope on that was controlling the speaking. That was one of the first things we did on the album, and it turned out to be one of the most effective. But some of it is Peter's voice. Peter's got one of the most amazingly controlled voices that I've ever run into. He can do so many different sounds

"It's all too easy to become thoroughly centered in your own little world . . . You need somebody to shake you out of your complacency sometimes."

with it, sometimes sounding human, sometimes not sounding human. You don't have to do a whole lot to Peter's voice to make him sound very bizarre.

Synapse: *Does he have an interest in synthesis?*

Fast: He's interested. He's a good person with a fine understanding of technology and the arts. That's one of his pet projects — all forms of technology: lasers, video, kinetic dance structures, and of course, electronic music. He tries to keep himself as educated as possible, and he does a great job on it.

Synapse: *Are you on his new album?*



PHOTOS: EVE KESSLER

Fast: Yeah. It's a little different. It tends to be a lot less electronic than the first one, which is surprising because Bob Ezrin produced the first one, and Robert Fripp produced the new one.

Synapse: How do you account for that?

Fast: Well, I think there's a tendency to try and explore new territories on the part of all creative musicians; and, in the case of Robert, who was very heavily identified with the electronic, orchestrated, big sounding European rock of the early '70s, his explorations are going in areas that don't involve any of that.

Synapse: I see. You've had quite a bit of experience in the studio working on other people's projects. Do you feel satisfied to be in a position where you don't have a lot of creative input?

Fast: It's a double-edged sword. Sometimes, it's really good because it exposes you to other approaches, and other ways of thinking. It's all too easy to become thoroughly centered in your own little world, and convinced that your own approach is the right way and the only way. You need somebody to shake you out of your complacency sometimes, and as long as it doesn't disrupt your own train of thought, it's good. Because sometimes you'll come into that

situation, and you'll learn something. Other times, you'll come away with a reinforcement of your own view that you do know more than the other person. I think that, working with rock people, it's better to maintain more control over the situation. But for straight session work, working with some of the older producers in the New York area, it's a real education to go in there and just switch off the pre-conceived notions about what should be done, and see what they come up with.

Synapse: So, what other projects are you involved in now? I understand you'll be touring with Peter.

Fast: Yeah, the Gabriel tour starts very early in August. I've been doing a little bit of work in computer video to go along with this album. I've been playing with the Apple-2, a very comprehensive little home computer system. It has color video graphic capabilities built into it. So I've been doing some of that combined with some regular video studio production, and some of what's been going down has been pretty exciting.

Synapse: How is it related to the music? Is there any hard wire relationship?

Fast: No, not at this point. Right now, it's all really a matter of video performance along with audio performance, although that's something that I want to start playing with. I do have the makings of a system that will be able to re-extract off of tape and do image control based on what the audio's doing. And then the other trip will be able to take the audio and derive it from the video, and do a self-programmed video thing.

Synapse: That would be interesting. Have you found any problem in your experiments relating the audio to the video? It seems, if you take the laser stuff, that what sounds good, doesn't usually look good.

Fast: Well, I think you might be a little more limited sometimes in lasers than you are in the video. Lasers are a little more awkward to control, and I guess, they're still very analog in their way, whereas the digital video is very controllable. But I think it's really more a matter of working with it to come up with images that make sense for the music. I'm sure that there's some budding genius out there none of us have run into yet, who's really great at that kind of thing.

Synapse: There are probably lots of them.

Fast: I think they are the next set of artists, in fact. They're just waiting for mass distribution of video forms the way the audio people have had it for so long, and they're perched on the edge right now; but if somebody were to get really bold and distribute something on Beta-Max or VHF format, I think there would be a decent market at this point already. There have got to be something close to a half million players out there by now. I know Rundgren is doing it, and also Kiss, both coming out this Fall.

Synapse: That makes sense. That would be the best medium for a group like Kiss. I'd like to ask you some specific questions about your new album. One thing that I found particularly effective was the sound of the high frequency things, like triangles. How did you achieve that?

Fast: Oh, some of that was enhanced because I used the Aphex. It was one of those things where everybody said you cannot use Aphex on synthesizers, so I patched it into the board during the mix, just to see what it sounded like; and on certain types of sound, it was really effective. It added that kind of psycho-acoustic sparkle back into the things.

I also spent a lot of time on percussion all through the album. It was all electronic percussion — lighter and heavier percussion sounds, I suppose you could say. Those sounds were derived on some of the tracks from a click track which was then extracted, sampled, and held through variable filterings.

Synapse: So then, you were using pulses through a resonant filter, is that correct?

Fast: Well, no. What it was, was that the pulses were just put down to maintain a regular beat structure; and then, several simultaneous sample and hold filtering systems were set up. And within those sample and hold parameters, the kind of planned accidents of percussion provided a very complex kind of feel; and the more the percussion was allowed to happen, the more polyrhythmic the whole thing began to feel. The actual sound generation wasn't all that complex, but the control became fairly exotic.

Synapse: A lot of what you do is very orchestral sounding, and I'd be curious to know what you use as a model. Do you use orchestral instruments as a model, or the concept of orchestration itself?

Fast: Well, I think those two things are tied together, and one of the things I've noticed in orchestrating, even electronically, is that when a piece has a more traditional approach, the sounds that are the natural ones for me to use seem to be continuations of the different instrument families in an orchestra. I

Good news from EML
SPECIAL PRICES
 Get more for your money. For a limited time we've reduced our prices on the board.
POLY-BOX
 Now add 26 additional pitch sources and a unique polyphonic capability to your synthesizer. Adapts to most synthesizers.
KITS FOR SYSTEM DESIGNERS
 Do it your way. Design a system that fulfills your own creative requirements. Complete instructions for special applications available.

Write or call today. **NOW CALL TOLL FREE 1-800-243-7270**

EML electronic music laboratories, inc. makers of ElectroComp Synthesizers
 P.O. Box H, Vernon, CT 06066 • (203) 875-0751

For Immediate Delivery of audio accessories

multiswitches[®]
 jack panels
 audio connectors
 A3F A3M

Send for our **FREE CATALOG!**

CALIFORNIA SWITCH & SIGNAL
 A complete line of audio accessories
 OEM Prices • Immediate Delivery
 13717 S. Normandie Ave., Gardena, California 90249 (213) 770-2330

NEED ANOTHER VCF...

If you have ever wanted to add another VCF, VCA, or even VCO to your existing synthesizer or system here is the answer... TAU SYSTEMS Synthesis Modules. These are assembled, tested, calibrated circuit boards containing Voltage Controlled Oscillators, Filters and Amplifiers as well as a DUAL ADSR envelope generator.

All modules cost far less than \$100.00, include quality front-panel rotary control pots and all jacks. All modules require dual 15 volt power supplies.

Here is a typical example:
 Our TAU SYSTEMS 1010 VCF offers a 24dB/octave slope with variable "Q" up to a self-generated, incredibly pure sine wave of 10 V P-P.
 It ranges from well below 10 Hz (CPS) to well beyond 30 kHz, accepts a 1-10 volt, P-P input offers precisely 1 volt per octave response over more than 8 octaves!

The 1010 is available on a PC board, assembled, tested and calibrated to 1V./Octave, with cable and controls for the very low price of only \$96.50, we pay shipping and include instructions.

The 1010 is also available in KIT FORM for only \$65.00.
 OVER 5 YEARS IN SYSTHESES PRODUCTS BY MAIL.
 (603) 382-5179

CFR ASSOCIATES, INC.
 Box F
 Newton NH 03858

OHIO ELECTRONIC MUSIC CENTERS

PI CORPORATION
 1741 E. 24th St.
 Cleveland 44114
 (216) 781-2207

And

CINCINNATI ELECTRONIC MUSIC
 115 Calhoun St.
 Cincinnati 45219
 (513) 281-9028

Dedicated to Electronic Music Sales & Service For:
 ARP, Moog, Sequential Circuits, Korg, Polyfusion,
 E-mu Systems, EML, A/DA Oberheim, Synare, 360 Systems,
 Eventide, MXR Mutron, Multivox, Buchla & Even More

have a feeling that it isn't so much because of preconceived notions of orchestration so much as the fact that those instruments are the ones that have survived for centuries because they were the most versatile, and most emotional sounding. The ones that were not particularly versatile didn't make it. They ceased to be written for, and they've become interesting antiques. The brass section, string section, woodwinds and percussion as we have it are the ones that have survived because they made sense. That's why, when I am working on some kind of an orchestration, I find that I end up with groupings of sounds that fall into those larger categories. That's not to say that I go for the best oboe sound I can get, or the best string sound; but sounds of that nature seem to make sense within that kind of orchestration.

Synapse: Have you done anything in terms of

waveforms and interaction of them that might account for that in terms of the hearing process?

Fast: Well, I think the one thing that I really have tried to achieve on the record is to re-introduce some of the psycho-acoustic properties found in conventional instruments that make them more complex than just the raw waveforms, and that involves the use of a lot of different types of echo and not just washing the whole thing with one type. When I'm creating a sound, it's not only what's happening in the synthesizer, but a whole studio is involved in everything from delay lines to the use of harmonizers for certain kinds of thickening; some envelope uses — flanging and phasing — things that make them tie in, and right out to the Aphex. So any kind of psycho-acoustic phenomenon that I can introduce back into that sound, I make use of.

Synapse: *What do you think of the potential of the synthesizer now that you've used it as a guitarist? Do you think it's going to be as accepted by the guitar player as it is by the keyboard players?*

Zappa: Here's the thing that really sucks about synthesizers: you get a guy a Mini-moog, and the first thing the guy wants to do is sound like a guitar player. Invariably. Every keyboard player has always wanted to bend notes all of his life. Now he can push the wheel and go wheeeee! and suddenly he thinks deep in his heart he's a lead guitar player. That sucks. Now you've got guitar players that always wanted to have clear attack, and they figure that if they plug into a synthesizer they're going to get clear attack; but the things don't trigger right, so that sucks.

Synapse: *You have to adapt your playing style to it.*

Zappa: Yeah. Well, if you're going to adapt your playing style to execute every note that clear, well, that's like starting from scratch again.

Synapse: *What have you been able to do with synthesizers that interests you that you weren't able to do without it?*

Zappa: Oh, it's definitely a relief, but the problem is the musicians. Since I'm not a keyboard player, I can't sit down and play my own orchestra music on keyboard, all right? So that means you gotta get somebody else to do it. I've invested thousands of dollars on very exotic, advanced synthesizer equipment. I have a humongous E μ set up, and I just spent another about \$8,000.00 on this special Hammond organ, that has special triggering stuff built into it, and we just had the audio premiere of this little noise maker yesterday, that triggers a modified Syndrum unit off of the keyboard which means that now a keyboard player can play scales on tom toms, and has the ability to actually do harmony runs on simulated instruments. Right now I've got my E μ dedicated to making the sound of a full brass section—in this case 5-part polyphony with an extremely realistic brass attack. I had it on the road for the last tour. The keyboard player who was using it couldn't even fathom what to do with it because when it came time to play a solo the first thing the guy did was get his little Minimoog out and go eeeee, you know? I mean, that's distressing to me. All I can do is make the equipment available. I have to go out there and beat my brains out to make the money to buy that shit. I buy it, I maintain it, and it's there to use, and I can't get people to use it right. And since the world of rock is an ongoing proposition and there are tours coming up, and there are albums here and there's a film there, you can't just sit and say, "Wait a minute. Stop. I'm going to search the world to find players who can actually operate this stuff and get the sounds out of it that are in it." You can't do it. You just keep on going. So you know what I've done? That big expensive E μ unit—it's in storage. Now the organ, which is a smaller more compact thing to take on the road will get its chance on this tour. If it doesn't perform in the hands of the player who's using it to the standards that I have set up here to make it work, it'll go into storage too. It pisses me off.

Synapse: *Do you think the synthesizer is just another instrument to be assimilated into music that's being made, or do you think it represents a point of departure?*

Zappa: I think it's just another instrument. As a composer, I wouldn't say I prefer a synthesizer to an oboe, or a synthesizer to a guitar, or a synthesizer to a harp or—I know what each of the instruments can do in terms of the sounds that it can make. I know roughly the kind of problems you have writing for the things, and roughly what you have to go through in order to get it performed. It's another instrument as far as I'm concerned. But to a synthesizer player of course, it's God. I mean we wouldn't want to interfere with the synthesizer player's little dream world.

Synapse: *Most of the time we've talked about synthesizers, you've referred to them in terms of imitating other instruments.*

Zappa: No. I just told you what I have in terms of equipment. I'm well aware that it can modify the sounds of things existing in nature, or it can make things which are not harmonic, stuff like the Vocoder—that is of limited use to the type of music that I like to write. I'm diatonic. That's the most radical thing you can do, is really be just diatonic.

Synapse: *When you're composing, are you thinking in terms of the different ways that it is going to be performed: the performance in the studio, the performance live...?*

Zappa: You have to think for the medium that is going to be the ultimate carrier of the information. If I'm writing a rock 'n' roll song I know that the arrangement of that song has to be suited to the place where it's going to have its first performance. Live performance arrangements have to be a different animal than recording arrangements, because you're dealing with a different set of problems. It's just different. So if you're writing an orchestra piece, there's an approach that a composer can take now that he couldn't take before. In the olden days if a guy was writing a piece, he wrote quantities and densities that were apropos of a live performance environment only. Based on what he knew about the performance of instruments, how loud they were, and what they could do tone wise, he shaped the composition. He would write down instructions on a piece of paper which, when interpreted by a conductor and the musicians sitting in the room, would produce a sculpture in the air.

In those days the air was not being shaken by tweeters and woofers, it was just by the instruments themselves: the air to the ear. Now, if you write a piece for orchestra, you have the option of saying, well, if this is going to be recorded, I can have a bass flute, which is a very soft instrument, be the loudest, most predominant instrument in the middle of a full brass section playing six f's, just by overdubbing him, and putting him on right there, and he'll stick out right in the front of the mass; and that's fantastic, you know? You can do things now with orchestration that you could never do before.

I think orchestras are fantastic. But the thing that I've always hated about being a composer, is dealing with musicians, because my experience is that musicians not only hate music, but they also hate com-

posers, and the only thing that they really like is their instrument, because the instrument is an extension of their own ego. The person that's playing the instrument says, "Hey, I'm playing, I AM PLAYING, this instrument," and has studied for years to play that instrument, and it's a strong identity from the person to his instrument. Nobody ever learned to play a violin to sit in the 18th row in the back of a section and go like that when the conductor waves his stick. They just aren't born to it. They all want to get out there in that one spotlight and Pagannini to death, you know? And it's the same for all players. They have such a strong identity with their instrument. They think that the instrument they play is God's instrument. You try telling a trumpet player that an accordion's where it's at, and see whether or not the guy just wants to strangle you. Why does a person decide to play a contrabassoon. What is it? They believe in it. The contrabassoon is their way of life, and you talk to bassoon players, they're so into it, OK? Everybody who plays something loves that instrument because it means something to them, and it relates to them personally. And in most instances, the composer is the shmuck that's getting in their way because he's telling them what to do. They don't want to know what to do. They want to play the instrument. "Just let me play. Let me be free," and meanwhile the composer is stuck with the horrible job of having to tell 120 guys what to play, when to play it, how loud to play it, when to stop, and all those things. He's doing the shittiest job. He's the organizer. He's like an umpire at a baseball game. Stick 120 musicians from an orchestra in a room, and tell them to play beautiful music without any music on paper. You could take the best players in the world, 120 of them, sit them down, and say, "Play me something beautiful." You gotta have organization, so the composer's job is organizing the time-space relationships of the sonic elements that are gonna shake the air. It's a fuckin' piece of drudgery. Does anybody care about composers in modern day America? No. Not unless the guy's writing a hit, writing a Pepsi jingle, or making some background music for a movie. I mean, composers are obsolete. Who gives a fuck about composers? Musicians don't. The experiences that I've had in Los Angeles writing music for orchestras and things like that have been harrowing. I'm the guy that's gotta pay for copying the parts. It's not enough to sit down there and figure out when they play and when they don't. I gotta pay for copying the fuckin' parts. When I did that performance at UCLA a couple of years ago, the total bill for the copyist was \$15,000.00 for 40 pieces.

Synapse: *But you do it because you want to hear it?*

Zappa: I do it for 2 reasons: 1, I want to hear the music. 2, I'm foolish.

Synapse: *Then you'll keep writing music for orchestra?*

Zappa: Yeah. I don't know whether or not I'm gonna keep paying to have it done. There's gotta be a better way. Because—you know the only time anybody ever came to me and said, "Will you please write some music for us?" Let me tell you this story—they said, "If you'll write a double piano

Continued on page 35

Allen Strange is the author of the well known book, *Electronic Music Techniques and Practices*, of which a second edition will be published soon. He is also a composer/performer working independently, and a founding member of *The Electric Weasel Ensemble*. As a teacher, his views on educating professional musicians will be of interest to educators and students alike.

by Doug Lynner

Doug Lynner: *How would you sum up what the electronic music scene was at the time that you wrote *Electronic Music Techniques and Practices*?*

Allen Strange: I think that can be summed up by the response from the publisher I chose to go with. They said, "We don't really see the need for this kind of material right now, but we'd like to contract it just in case." It was certainly meaningful to me and other composers, and I guess that's who I was writing for. I was not looked on favorably by many of my colleagues because of the book — for aligning myself with the *aesthetic*. They said, "What are you doing?"

Synapse: *I'm not sure I understand. Why did they feel . . .*

Strange: Oh, well, it was like the guitar at a university back in those days. A guitar player comes to college and says, "I want to major in guitar." And they say, "Well I'm sorry, we don't deal with such mundane . . ."

Synapse: *Lowbrow?*

Strange: Yeah. "You'll have to switch to string bass," which is exactly what happened to me. Same thing. Somebody comes and says he's a composer and says, "I want to learn about electronic music." And there were maybe three or four universities at that time that even recognized it. It was just a bad word in certain teachers' minds. So here I come out with a book on the subject and . . .

Synapse: *You become the epitome of what threatens them.*

Strange: Sure.

Synapse: *How did that affect things as you went on from there?*

Strange: Oh, it got me tenure. Those were weird days. It's not like that any more. It's certainly a respected field by now. I'm trying to change that.

Synapse: *The manufacturers, in their role of making things on one level accessible, but sometimes on another level obscure, is an interesting problem. For instance nomenclature. A trajectory controller is an envelope generator, which is now a transient generator; and words such as growl, which I don't even know the definition of.*

Strange: That's what I do when the students don't practice.

Synapse: *That makes sense. How much of the responsibility for solving these ambiguities do you think rests on the manufacturers' shoulders, and*

how much do you think rests on the shoulders of the educational institutions?

Strange: Boy, am I going to get in trouble. It's my feeling that the manufacturers that use the least amount of hype make the most reputable instruments: the ones that say, "Here's how much it costs, and here's exactly what it does." I find those instruments are much easier to relate to because they're truthful. If I go into a music store and it says, "Here this thing is, and here's what it does, and here's how much it costs" — great, I know exactly how to work it. Relating to your trajectory controllers and your growls and your whatever marvelous terms they're using these days, it does nothing more than just confuse everybody. And they get unhappy. They spend X number of dollars on system X, and in a year they've outgrown it because they've been taken in by the hype. And that eventually hurts everybody. I've had some budding young performers and composers that have gone through the classes, and they say, "Now it's time to buy a system. Which one shall I get?" I'll say, "You should know which one you want." And they go out and buy something, and in six months they're discouraged because they read ads in *Guitar Player* and *Synapse*; and so unfortunately, right now the burden of that problem lies with the educator. I don't mean the educator strictly in the academic institution, but like the people next door at Sound Arts, who hold classes. I guess the syndrome is characteristic of any new instrument. Violin makers don't use that sort of advertising. Even electric guitar manufacturers don't. Their ads are pretty straightforward, and I guess that's because the instruments are known. You can't hype anybody with an instrument that has a long history. On the other hand, here comes something new. Now, what's the fastest way to make a buck? Well, let's call it a space — trajectory — rotary — control — phaser — digital whatever. The young kid comes in and goes, "Wow, yeah, I'll buy six of those," and he takes it home and finds out that it is nothing but an envelope follower and a phaser. I don't know if I have answered your question.

Synapse: *I think you have. Why don't we talk about your own music at this point?*

Strange: I'd much rather.

Synapse: *Let's start with the Weasel Ensemble.*

Strange: The Weasel Ensemble consists of five people: myself, my wife Pat, Steve Ruppenthal, Dave Morris, and usually Don Buchla.

Synapse: *What's the idea behind the group?*

Strange: Just to play, to perform. It started in 1974 when Don first released the Music Easel, and a bunch of the users decided to put on a concert to show people about the instrument. Somehow the concert turned out to be the Third Annual Weasel Festival. Why it was the third I don't know. We decided the group should have a name, and jokingly it became the Electric Weasel Ensemble, the core of which at that time was Pat, myself, and Don; after the concert, people started going their different ways and Don, Pat and I continued to concertize sporadically. At some point I said, "OK, we should get serious about this." The other two people joined in 1976. We do a lot of sound poetry: sound-text composition. Ruppenthal is a well known scholar and writer in the field of sound poetry, and so he has brought that to the group. Dave Morris is our spiritual leader. He's a minister of Scientology.

Synapse: *Really?*

Strange: Yeah. He was one of my students at San Jose. He's primarily a rock guitarist. We don't do any commercially oriented music — not that I

would mind doing any, it's just that there's so much other stuff to do and pieces to learn that we haven't got around to that yet. We would probably make more money.

Synapse: *Are there compositional ideas that you're really working on at this time?*

Strange: I'm interested in tuning systems, my own specifically. I got the idea one time to try to orchestrate side bands because of the linear placement of the pitches. It was a piece for fourteen flutes and it really worked to my satisfaction. This was in 1969. Since that time, all of my acoustic music has been exploring a linear tuning system. There are incredible notational problems because the pitches don't lie within any known gamut of tuning and it also poses the problem that there is no octave in linear music; so it takes a long time to get these people as close as possible. That "close as possible" is a very nebulous region. There's no way they are going to get right on, but I find if they detune enough in the right direction, at some point it will click. I'll say, "Aha, that's it." And they will be able to do that again. I'm interested in the distribution of sound in space, more than the movement of sound. Right now, I'm working on a piece for a collection of consorts of winds — clarinets, trombones and horns. Each consort is separately amplified, and as they play, the sound undergoes composed patterns of movement. And so, as two sounds converge, say from 12 different points in the room, they would take on similar musical characteristics — pitch, rhythm, whatever — and as they crossed, their identities would be the same.

Synapse: *In the electronic pieces, are those relationships that occur and then change in time and proximity, at all an automatic process; or are those various processes composed over each other? For instance, would you have the materials and then do the sounds and then do the movement patterns?*

Strange: No, no.

Synapse: *Or would those all be related in the structure of . . .*

Strange: They're all related. I'm afraid I'm a very formalistic composer. I have my heritage, I guess.

Synapse: *When you are using the linear pitch concept with electronic pieces, how do you deal with getting that scale? Do you tune the keyboard to . . .*

Strange: No, you can't. Well you can with a different kind of keyboard. You can with a computer very easily. With my particular instruments, I'm locked to equal temperament, not necessarily 12-tone, but I'm locked to equal divisions of some interval, and those divisions are exponential pitches. What I need is a real linear oscillator. I don't mean linear FM, but linear control oscillators; or I have to be able to de-tune the keyboard. And that's possible with analog equipment. You would use an analog address sequencer so that key number one goes to increment one, and you can tune that to any pitch you want. Unfortunately, I don't do that because I don't have an analog address sequencer. What this boils down to is, my music for the electronic medium is not melodically oriented. It's more timbrally organized in terms of density. And I guess my acoustic music is the same way, now that I think about it. There are no tunes. Really what I'm composing is clangs, and so the sense of melody in the traditional respect of the word doesn't exist. Another aspect of my music is that I'm very event conscious. I don't mean on the level of musical events, but what this music is going to be used for.

Synapse: *Kind of programmatic?*

Strange: Well, not in the romantic sense of programmatic. I've been fortunate enough in the past

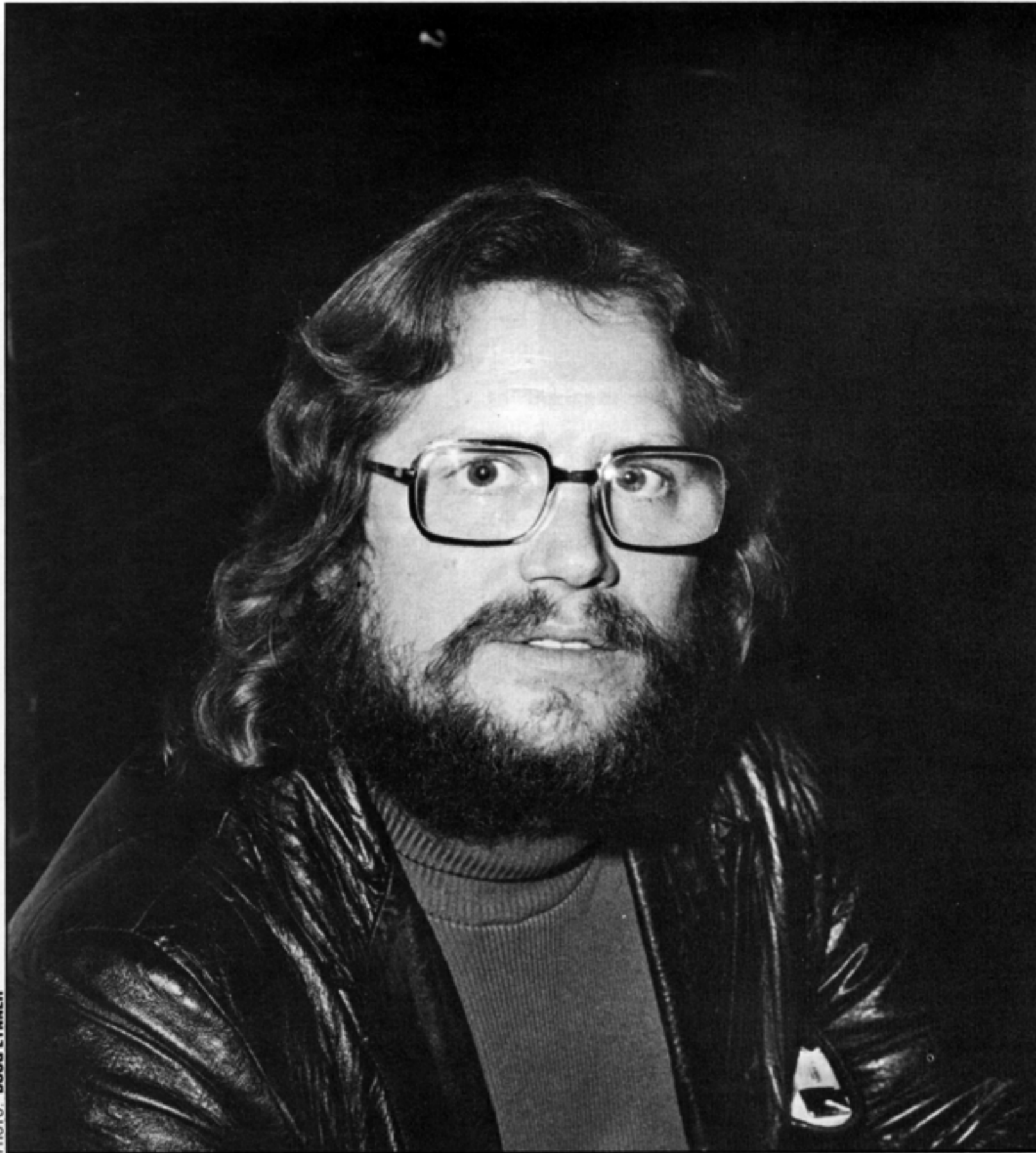

PHOTO: DOUG LYNNER

years to work almost entirely from commissions; and so I know who I am composing for. This is an attitude that rubbed off on me from Bob Erikson. He works very, very carefully with whoever he's composing for. He learns what this person's pallet of sounds are, what he can do, how he can change them, and then he writes a piece really for that person. I am the same way but not as detailed as Bob Erikson was. I envision more of the concert itself. Like, if I know I'm going to write a piece for a chamber setting, then I know what kind of musical dynamics I want to work with. I don't mean dynamics in terms of loudness. Or if I'm going to be writing for a planetarium, that will bring another kind of dynamic to mind. I like to leave a lot of room for the performer. I hesitate to use the word improvisation, although somebody else would.

Synapse: But essentially what you mean is that you like to leave in the score the ability for the performer to make some decisions.

Strange: Sure. A lot of my scores have the attitude of the head chart for a jazz musician. Not in the sense that I notate the tunes and changes, and say, arrange it; but still, the structure is there. All the important things that I want to control are there, and the leeway that I'm going to allow the performer to take is built into the piece. So I don't think you can do it wrong.

Synapse: Why is that aesthetic important to you?

Strange: Because I'm an old rock and roller. I

"It's my feeling that the manufacturers that use the least amount of hype make the most reputable instruments."

grew up with that attitude.

Synapse: Last night at dinner you mentioned to me that one of the trends in education in this state is the possibility of centralizing pursuits to particular campuses.

Strange: I have no idea whether that's going to come about, but I know it has been talked about quite seriously.

Synapse: It seems that the possibilities are, 1) making the information available in as many locations as possible, or, 2) finding some way to concentrate the people that will go to the one campus. I'm interested to know as an educator what you think of these potentials? What situation do you see developing?

Strange: I would have hated to be a student where every one of the composition classes were the best available.

Synapse: Is that because of intimidation?

Strange: Yeah, I think a certain amount would have been intimidation. I know the cliques that evolve around certain high powered organiza-

tions, and I don't know if that would be such a fruitful situation or not. I don't think I want to pursue this.

Synapse: OK. Is this compromising to your position?

Strange: Yeah, because I'm going to have to say something eventually that is going to put down the system for which I work. You can print that.

Synapse: That's an honest answer. Maybe we can pursue the idea of how to educate on another level. Another possibility that is now growing at a pretty fast rate, is non-institutional education for music students, which would seem to me to be a real healthy thing.

Strange: Definitely.

Synapse: One of the differences that I see between the two types of education is that the non-institutional courses often operate around a production facility. And it would seem as if the emphasis there would go towards actual production as opposed to information that you will later utilize. I wonder about that production aspect in institutional education. Is there any trend in that direction, or is the trend to . . .

Strange: Not as far as I can see. I certainly wish there was. Right now we hand out degrees to music majors in various areas of music who have done really no more than take classes, and say, "Now, Jane Doe, you've got your degree, go give a concert," and they are terrified. They can't do it without the supervision; somebody holding their hand. My idea of education in any kind of art is to keep, I guess you'd call it a scrapbook, a file of the students, and say, "You're going to take these classes and go out and apply that information. When I see evidence of that information being applied to the point where you're self sufficient, you get your degree." And at that point the degree is a very meaningful piece of paper that means this person can produce, this person can survive professionally. There are some schools that are very, very aware of this. What they are doing is abolishing grades in certain state supported institutions, and the teachers at the end of the semester or quarter actually write up a report, and it's a hell of an administrative job. You have to sit down and essentially write an essay on what the student has done every year. That's much more meaningful than a grade. If somebody is going to write something about you, you're going to have to do something for them to write about. A student can hand me ten papers, and I'll write one thing; but a student can go out and do one concert and I'll probably give him a better write up than the student with ten papers. I see an unfortunate trend in a lot of education to minimize performance, especially if you're being trained as a music teacher, and that's absurd. How in the world can you teach music when you can't make music yourself? There's a problem in the California State Universities called the Ryan Act, and what it is, is how to get through a teaching degree in the minimum amount of time. And, at least in the music departments, most of the upper division education in terms of theory, method, and performance is all done away with. And here these people graduate with teaching credentials and go out and teach a new generation of people who will eventually become teachers with less skills than their teachers, and then they will graduate, and it diminishes, and diminishes, and diminishes. That's silly. And then the educators wonder why the trend is diminishing enrollment. Well, the students are figuring this out.

Synapse: They are looking for an education.

Strange: Yeah, and they're going to the studios. They're knocking on doors and saying, "Look, I'll

the Craig Anderton Music Tape

Craig is well known for his articles that have appeared in *Popular Electronics*, *Modern Recording*, *Guitar Player*, *Synapse*, *Polyphony*, *Contemporary Keyboard*, and many others... as well as his two books on musical electronics and recording.

Now, you can hear the music behind the articles. This entire tape was written, played, and produced by Craig in his home studio, using voice and a variety of traditional and electronic instruments. A supplemental booklet gives lyrics, as well as a complete description of the instruments and processing techniques used in each piece.

This unique tape contains over 40 minutes of innovative, original music, and is distributed by PAIA Electronics, Inc.



PAIA Electronics, Inc.

1020 W. Wilshire Blvd.
Oklahoma City, OK 73116

Please send me _____ C. A. Music Tape(s)
at \$5.95 each.

Name _____

Address _____

City _____

State _____ Zip _____

S A

**ELECTRONIC MUSIC:
IN-HOUSE PRODUCTION
SCORING/ARRANGING
RECORDING • RENTAL
SALES • CONSULTATION
INSTRUCTION • 2825
HYANS ST. LOS ANGELES
90026 • (213) 487-5148**

Sound Arts

be your gofer for a year, because I want to learn what music is about." I'm talking about the commercial end of things. Or they align themselves in an apprentice situation with another composer or performer. I know in my concerts, the students in my classes who are really interested become roadies. And they're thrilled to do this, and I'm thrilled to have them too, because they're learning how it's done.

Synapse: How valuable do you feel it is for your students to expose their music to an audience that is not their peers and colleagues?

Strange: It depends on what they want to do with it. If they're aspiring to be composers, it is very valuable. Some of the people have very, very special interests in mind beyond the realm of pure composing — dance, film, so on — and in that case, I don't have to be concerned with it because I know they are going to make a dance form out of it, or a film score. When it's just pure music, composers are sometimes a little bit hesitant to put it out there. I think what you can do as a teacher is provide an outlet for that. Encourage the students to enter the XYZ competitions. All they can do is lose. I see a lot of mutual support in students. So many of the activities you see happening around the country are actually student organized, student run events. And that's very good. That's great. It didn't used to be like that back in the old days. It's still competitive, but I think that musicians today are starting to see the need for what we call visibility in the academic world. They're starting to make that visibility happen for themselves rather than relying on teachers to do it. I think part of the teacher's responsibility is to help get the students to step out in public.

— HARDWARE REALIZATIONS — FOR SYNTHESIS:

The Voltage Controlled Analog Delay— One of the new generation of devices that have extra long delays and cleaner sound.

The Voltage Controlled Phase-Filter — A phase shifter and low pass filter in one module; accurate exponential control and programmable architecture.

The Digital Pattern Generator — For sequencer control voltage subtleties, with some unique properties.

The Frequency Divider — For those fat sounds - - plus frequency dependent event triggering.

The Voltage Controlled Clock With Programmable Event Arrangers — To maintain structure in complex sonic events.

If you're building your own synthesis equipment or adding to commercial devices, one of our high-quality CMOS kits is just what you need. All of them are designed to be compatible with existing modular or prepatched equipment. The Analog Delay and Phase-Filter make great effects boxes. For more information drop us a line along with a fifteen cent stamp. We'd be glad to hear from you.



BLACET MUSIC RESEARCH

18405 OLD MONTE RIO RD.
GUERNEVILLE, CA.
95446

FOR A GREAT AUDIO ADVENTURE

A new, exciting discovery in great sound awaits you in *THE AUDIO AMATEUR* MAGAZINE.

It's delightfully easy to improve, maintain, and even build your own audio components. Thorough articles—everything from amps to speakers, simple add-ons or improvements to intricate modifications—help even our non-technical readers develop superior sound equipment.

Subscribe now on a guaranteed satisfaction basis or send for our **FREE** prospectus.



HANDY COUPON

Fill in the coupon, include a check or money order payable to *The Audio Amateur* and send to TAA Dept. S1, Box 176, Peterborough NH 03458 USA.

- Enter my sub for TAA for one year/four issues for \$9.
- I want to know more. I enclose \$2.50 plus .50 cents postage for the current issue of *The Audio Amateur*.
- Send free prospectus.

Name _____
 Street _____
 City _____ State _____ ZIP _____

Foreign subscriptions are \$10 per year and all remittances must be in US funds.

THE BOSTON SCHOOL OF ELECTRONIC MUSIC

FOUR SEMESTER PROGRAM OF ANALOG AND DIGITAL AUDIO SYNTHESIS

First Semester Courses:

- INTRODUCTORY AUDIO SYNTHESIS
- MUSIC THEORY
- INTRODUCTORY ELECTRONICS
- PREPARATORY LOGIC AND MATH
- SURVEY OF ELECTRONIC MUSIC

Next Semester begins February 5. Also, intensive Winter Session is being conducted January 8 through February 2.

THE BOSTON SCHOOL OF ELECTRONIC MUSIC
 28 HIGHGATE, ALLSTON, MA.
 02134 (617) 782-9100

NEW YORK'S MUSIC DEPARTMENT STORE

JUST A FREE CALL AWAY!
 800-645-3518
 SAM ASH MUSIC STORES

Buy direct from our 6 huge stores and warehouse. All musical instruments, amplifiers, electronic keyboards, discos, PA's, pianos, organs, accessories, music. Call for prices or mail your list of questions. NYC area residents, please visit us in person. NY state phone 212 347-7757. Since 1924

From page 31 concerto, the Los Angeles Philharmonic will play it. If you'll buy two 11 foot grand pianos and donate them to UCLA. Do you know what an 11 foot grand piano costs?

Synapse: Too much.

Zappa: Now how do you like that shit?

Synapse: And that was the only time you've been asked?

Zappa: That's the only time anybody asked me to write any music—if I would buy two fuckin' grand pianos.

Synapse: You mean, you haven't been approached to do film scores?

Zappa: Oh, somebody asked me to do a film score, but, what is that, you know? The producer of the movie says, "Bring the cellos in here, they're falling in love."

To be continued next issue.

Synapse

EMS VOCODER 2000
 for the treatment and modulation of human speech and the production of speech-like effects from music or other sounds. Used by radio, television, studios, groups and theatre.

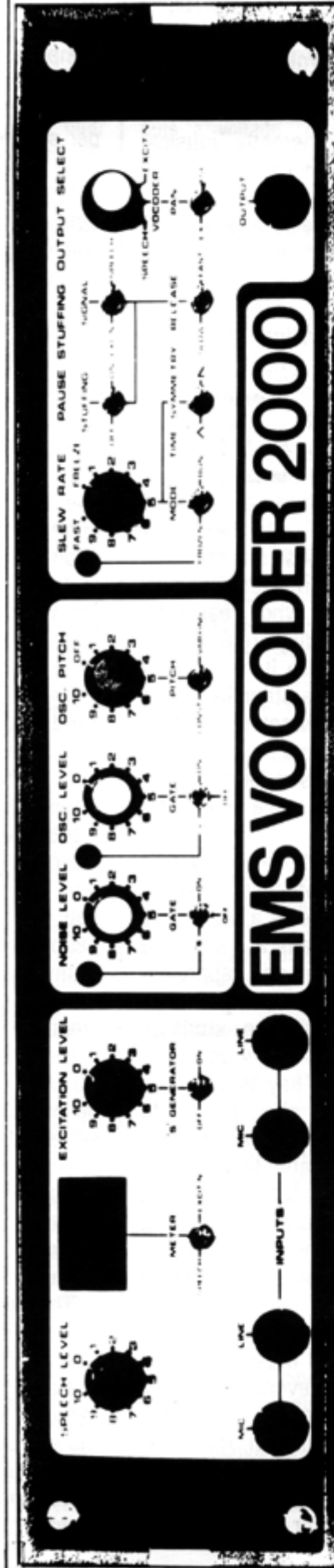

Zen On Music Co Ltd
 25 Higashi Gokencho
 Shinjuku-Ku
 Tokyo

Electronic Music Studio Supplies
 5832 Westminister Avenue
 Montreal
 Quebec H4W 2J8

Piano Center
 122 Rue de Paris
 Montreuil 93100
 Paris

"No United States agent yet."

EMS West Germany
 7257 Ditzingen 3/Hiemeringden
 Finkenstrasse 4
 07152 - 53273

EMS The Priory
 Great Milton
 Oxford
 08446 - 729



Developing The Basics

This is the first article in a new, continuing column in *Synapse*. The purpose of this column is to describe the way modules within a synthesizer operate and to define the necessary technical terms needed to understand the descriptions. Most important, it is a column for musicians.

Learning the synthesizer is completely unlike learning any other instrument. The synthesizer evolved from laboratory test equipment—oscillators, filters, amplifiers—and there is little inherently musical about a synthesizer. Other instruments evolved from still other instruments so there is a good deal of "musicalness" built into their structure. There is little, for example, that a guitar can reasonably be, other than a musical instrument.

Because of the inherent lack of musicalness within a synthesizer, making music with it becomes a two stage process. First, the synthesist must patch the collection of modules into a "musical" configuration and second, play the instrument he/she has just created. The first stage is overlooked by keyboard performers who treat their synthesizer as a fancy organ or who believe that because it can have a keyboard, it is like other keyboard instruments. Incompetent synthesis in pop/rock/jazz has become the norm. The reason for this general lack of competence lies in the learning process.

Learning a traditional instrument is a prescriptive process; learning the audio synthesizer is a descriptive one. Many musicians are unaware of this difference and approach learning the synthesizer prescriptively. Often, beginning students ask questions like, "How do I get a trumpet sound?" They assume that in learning, they should be told what to do (the prescriptive method), and then they intend to diligently memorize the knob settings. This is totally inappropriate in learning synthesis because it completely ignores the first stage. Patching up the "instrument" is one half the creative part of synthesis, and it is in this area that musicians must learn techniques beyond those they already know in order to become competent. Learning in this area is a descriptive process in which one learns what a specific module is and how its output changes as a

result of changing inputs and controls. This column, then, is a descriptive column. Since voltage controlled oscillators (VCO's) are basic to all synthesizers, we will begin by describing them.

An oscillator is a source of periodically fluctuating voltages. These voltages, output from the VCO, have three significant characteristics: frequency, amplitude and waveshape. Frequency is a measurement of how many cycles there are in one second, a cycle being one complete voltage fluctuation. Frequency is measured in Hertz (Hz.) and 1 Hz. is equivalent to one cycle per second. Amplitude, specifically peak to peak amplitude, is a measurement of the voltage difference between the highest and the lowest voltage levels within one cycle. Finally, waveshape describes the form of the cycle, or the manner in which the voltage changes within one cycle. When these voltages, which are electrical energy, are changed into sound—mechanical energy—by a loudspeaker, each voltage characteristic determines one sonic characteristic. The frequency of the signal determines the pitch of the sound; the amplitude of the signal determines (in part) the volume of the sound, and the signal's waveshape determines the sound's timbre.

There are four basic waveforms used in audio synthesis and often each waveform is available at its own VCO output jack. These waveforms are the sine wave, triangle wave, pulse wave, and sawtooth wave. Early in the 19th century, the French mathematician, J.P. Fourier, determined that all complex periodic motion can be analyzed in terms of a set of sine waves, each with a particular frequency and amplitude. These individual sine waves are called harmonics and all waveforms produced by a VCO could be produced by mixing together a series of sine waves, each sine being one harmonic in the complex waveform. This process, called additive synthesis, was once a common electronic music technique.

The waveforms can be represented on two different kinds of graphs. The first of these is a time domain graph. It plots the instantaneous amplitude of the wave on the vertical axis against time on the horizontal axis. One cycle of the waveform is represented on a time domain graph. The other graph is a

frequency domain graph and it plots the amplitude of each of the harmonics on the vertical axis against the frequency of the harmonics on the horizontal axis. This graph, then, is a representation of the frequency and amplitude of each of the harmonics; each harmonic is itself a sine wave.

The harmonics of a sawtooth wave occur at frequencies which are whole number multiples of the fundamental frequency. The fundamental is the first harmonic so if the fundamental is 440 Hz., then harmonics occur at 880 Hz. (2x 440), at 1320 Hz. (3x440), at 1760 Hz. (4x440) and so forth. The amplitudes of each of these harmonics are determined by multiplying the reciprocal of the harmonic number times the amplitude of the fundamental. If the amplitude of the fundamental is 10 volts, then the amplitude of the second harmonic is 5 volts ($1/2 \times 10$); the amplitude of the third harmonic is 3.3 volts ($1/3 \times 10$); the fourth harmonic has 2.5 volts amplitude ($1/4 \times 10$).

The triangle wave has a different waveshape so it necessarily has a different harmonic structure. The triangle has harmonics at all odd number multiples of the fundamental frequency. If the fundamental is 100 Hz., then harmonics occur at 300 Hz., 500 Hz., 700 Hz., etc. The amplitude of each harmonic is determined by squaring the reciprocal of the harmonic number and multiplying it times the amplitude of the fundamental. So the 3rd harmonic's amplitude is 1.1 volts ($1/3 \times 1/3 \times 10$); the amplitude of the harmonic at 500 Hz. is 0.4 volts ($1/5 \times 1/5 \times 10$).

In determining the harmonic structure of the pulse wave, an additional step is necessary and some additional description. A pulse has only 2 states, high and low. During one cycle, the amount of time the pulse is high is called the pulse width percentage; thus a 50% pulse wave is high for exactly one half of each cycle and low for the other half of the cycle. A 20% pulse spends one fifth of each cycle high and four fifths of the cycle low. To determine the harmonic structure of the pulse, first determine the pulse width percentage. Let's assume we're dealing with a 25% pulse. Convert the pulse width percentage into a fraction, in this case $1/4$. This fraction is called the duty cycle. The denominator of this fraction specifies which harmonics

are missing from the spectrum. A 25% pulse, then, has every fourth harmonic missing, or harmonics at the following multiples of the fundamental frequency: 1,2,3,5,6,7,9, 10,11,13,14,15,17, A square wave is sometimes treated as a separate waveform because it is often used in audio synthesis, however it is simply a 50% pulse.

A sine wave, of course, has only one harmonic and that is the fundamental. After you understand the basic outputs from the VCO, consider the inputs into the module. Although various manufacturers offer different inputs to their VCOs, common to all VCOs are one or more inputs which enable voltage control over the oscillator's frequency. Typically, the sensitivity of frequency control inputs is 1 volt per octave. In other words, if there are 0 volts present at this input, and the VCO is oscillating at 100 Hz., patching a 1 volt signal into the frequency control input would cause the VCO to oscillate at 200 Hz., or an octave higher. Patching a 2 volt signal to the input would raise the original frequency 2 octaves, or to 400 Hz. Three volts would raise the frequency to 800 Hz., or three octaves higher. Notice that the octaves are increasing exponentially, while the control voltage increases in a linear fashion. Inside the VCO is a device called an exponential current generator which converts linear voltage changes into exponential voltage changes to provide for this musically useful 1 volt per octave sensitivity.

Many manufacturers provide voltage control of the pulse width as an input to the VCO. Positive voltages applied to this input increase the pulse width while negative voltages decrease it. Although there is no industry standard for the sensitivity of this input, on a number of different instruments, the pulse width changes 10% for each control volt. There are several other features which various manufacturers offer as voltage control inputs to their VCOs, however it is beyond the scope of this article to deal in detail with each of these. If there are any questions regarding these specialized and more esoteric inputs, write to me care of B.S.E.M. and I'll send an explanation. If there are a sufficient number of the same questions, we'll take up the topic in a future column.

—Kenneth Perrin

Controlling & Interfacing Synthesizers

Interfacing

Interfacing usually refers to playing two or more separate synthesizers from one keyboard, fretboard, wind, pressure, or other controller. Information is conveyed from the controller to each synthesizer. Two kinds of information can be so interfaced—timing and structural information. The structural information could simply be an electrical voltage proportional to the note expressed—an analog C.V. (control voltage). Or it might be digital or hybrid information. Whatever form this control takes, it and a timing pulse are the controller's output.

The timing pulse is used to start events like envelopes, sequences, tape loops, etc., while the structural information determines oscillator and filter characteristics, thus pitch and timbre, or a tonal center. Subsequent modulation about this center is determined by synthesizer settings and acoustic environment, as well as by secondary controllers like knobs, wheels, ribbons and pedals. Such devices may or may not require additional control ports and separate interfacing. Obviously, the slaved synthesizer must be able to read any information which the controller sends it.

Timing Pulses

Each key of a keyboard controller closes a mechanical switch consisting of a contact and a bus rod. The bus rod carries a voltage which is transferred through the key's contact and out from the controller as long as the key is down. This gating effect can be used as the timing pulse, or used to initiate the timing pulse. The timing pulse provided on Moog synthesizers is called a switch-trigger. It is a negative-going gate. In other words, it is about 10 volts when all keys are up and drops to zero volts when a key is down. ARP synthesizers provide two timing pulses, one called a gate and one called a trigger. The gate pulse is positive-going. Key-up is zero volts, key-down is about 12 volts. The trigger pulse is a short voltage spike, slightly delayed from the gate pulse, and is produced whether other keys are down or not (multiple triggering). Slaving an ARP to a Moog keyboard requires inverting Moog's S-trigger and differentiating a voltage spike from it. Although the Minimoog's S-trigger port is labeled as an input, it is effective here as an output. Slaving a Moog to an ARP keyboard requires just an inversion of the gate output from the ARP. Oberheim modules are easily set up to accept either ARP or Moog timing pulses.

A question arises concerning exactly when a timing pulse should be output.

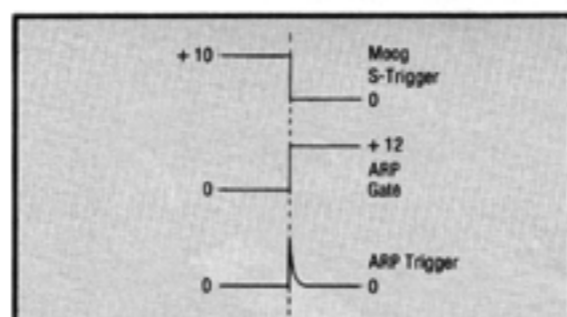

Fig. 1: Synthesizer Timing Pulses.

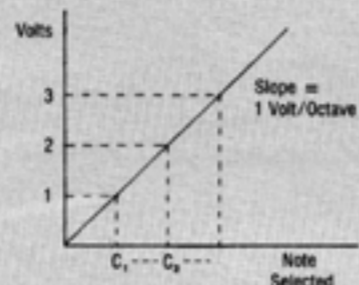

Fig. 2: Linear Control Voltage.

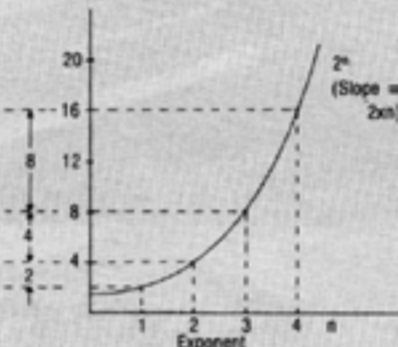

Fig. 3: Exponential Scale.

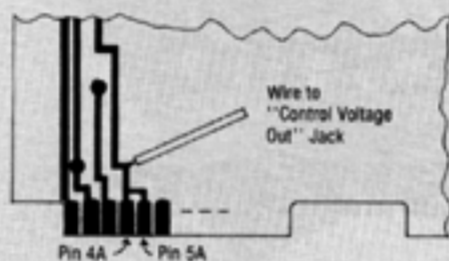

Fig. 4: Minimoog Board No. 2.

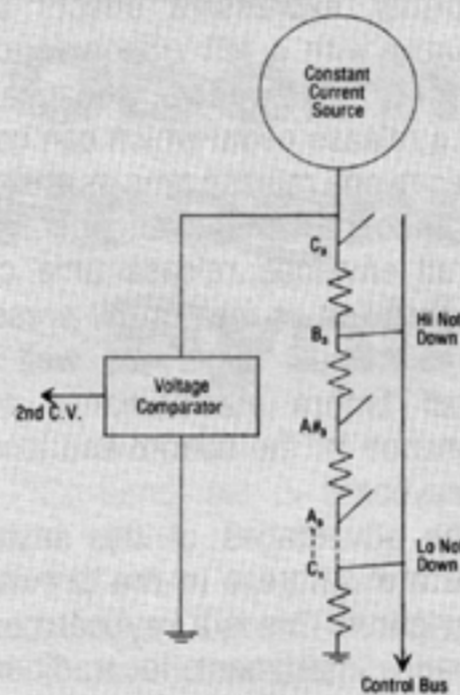

Fig. 5: Two Voice Operation.

The bus-contact system just described possesses absolutely no sensitivity like its progenitor the piano keyboard, or any acoustic instrument for that matter. How hard does its key have to be hit to close the switch and initiate a note? Improved versions of the bus-contact system are available which are sensitive to key velocity, pressure, or both; but when inherently sensitive instruments are used as controllers, a sensitivity threshold must be set in order to avoid generating unintentional pulses.

The ARP Avatar, for instance, provides a trigger sensitivity adjustment for each string which is adjusted to the guitar player's picking technique. The Avatar also monitors and analyzes the energy content of the string's vibration

and blanks out any timing pulse which is not followed by a solid note. ARP's standard gate and trigger pulses are then generated and made available on the rear panel for interfacing. Ampeg's Patch 2000 guitar controller has specially wired frets which sense string contact, somewhat like the bus-contact gating system. Gate, trigger and S-trigger pulses are then made available for interfacing. No inboard synthesizer is included.

Control Voltages

Analog control voltages are a commonplace interfacing signal. The selection of a note sends out a DC voltage proportional to it. This voltage is used to control the pitch of the oscillators and also the cut-off frequency of the filter (to maintain even timbre the filter cut-off must rise with the pitch of the oscillator). Often, there is a linear C.V. scale of one volt per octave, meaning one-twelfth volt intervals between the notes of an octave. Human perception of pitch, like volume, is not a linear function however. Successive musical intervals which we perceive as comparable, like the octave, do not span equal frequency intervals, but rather exponentially increasing intervals. An exponential relationship results from raising any number to increasing powers or exponents. In fig. 3, this is done for several exponents of two. Note that each successive operation results in an interval twice as big as the last.

In the same way, each musical octave spans twice the frequency range of the last. Each of the twelve tones within the octave are also exponentially spaced—each successive interval stretches one-twelfth root of two farther than the last. Twelve tones span twelve twelfth roots of two, or simply, twice the starting frequency, one octave. Thus the equally-tempered or "engineered" scale.

Actually, the most pleasing musical intervals are based on whole number ratios of the starting frequency. Scales based on these ratios are called chromatic or Pythagorean scales. The ratios generate slightly different values for a scale than does the equally-tempered method. Chromatic scales get progressively less tempered if one of the chromatically generated notes is used for a new starting point, that is, as key signatures are changed. The equally-tempered scale is a good average of all twelve chromatic scales, and has the advantage of not changing with key signature. An instrument with a range that favors a B-flat starting point, for instance, can be played with instruments that favor other starting points when using the equally-tempered scale.

Keyboards are easily adapted to selecting control voltages. A string of precision scaled resistors, one for each key, in the path of a constant DC current develops the required voltage steps. Depressing a key connects the control output bus to the voltage which corresponds to that note. When two keys are

down the resistors between those keys are shorted out by the shared output bus (see fig. 5). The voltage on the bus will correspond to the lowest key down because the current source is designed to deliver a constant current while the resistance below the shorted section hasn't changed (low note priority).

This keyboard scheme is compatible with two-voice operation. Because the resistance of the entire string decreases when two or more keys are down, and because the current remains constant, the voltage developed across the string will decrease in proportion to the interval between the highest and lowest notes depressed. When the voltage drops, a comparator senses the change and outputs a voltage corresponding to the interval shorted. By summing this interval C.V. with the low note C.V., a control voltage for the high note is obtained. Such methods are used in two-voice synthesizers like the ARP Odyssey and the Cat.

The Minimoog provides for two control inputs, one for the oscillators and one for the filter, but provides no output port from the keyboard. Fig. 4 shows where a 1 volt/octave keyboard C.V. is available. A wire can be soldered to this point and run to the tip of a 1/4" phone jack and mounted on the rear panel for interfacing. The pitch and modulation wheels of the Mini produce C.V.'s separate from the keyboard C.V. To control other synthesizers from these wheel controllers requires separate, but not unreasonably difficult interfacing. The pitch bending devices on patchable ARP synthesizers produce a C.V. which is combined with the keyboard C.V. prior to its output from the controller. This means that the interfaced synthesizers will follow the pitch changes of the inboard oscillators. On the 2600 (two-voice) a vibrato can also be summed into the C.V. output.

Single Bus Keyboard Systems

While the Minimoog and patchable ARP synthesizers use separate busses for timing and control signals, the Micro-moog and Moog Taurus synthesizers use a single bus. Control voltages have superimposed on them a high frequency AC signal. It rides along on the bus with the C.V. when a key is depressed. The AC and DC components are then separated. The DC part, the ordinary C.V., is sampled and held. The AC part is rectified to provide direct current which closes an electronic switch, thereby creating a timing pulse. Like the Minimoog, this is a single trigger system. Once a key is down, no additional triggers are generated until it is released. The Micro provides S-trigger in and out ports and a keyboard C.V. out, which can be switched to an input on newer models. No effects are summed in with the keyboard C.V.

The Minimoog also has only one keyboard bus, but uses no superimposed AC. Rather, it detects DC voltage changes

Continued on page 46

ILLUSTRATION: COLIN GARDNER

EQUIPMENT

This is a second in a series of product evaluations by Dan Wyman. Dan is a studio musician in Los Angeles, and owner of Sound Arts Recording Studio.

The Yamaha CS-80 synthesizer is a blend of several traditions in keyboard instruments. For pianists, velocity control and pedals for expression are included, and of prime importance. For the organist, a face panel design and nomenclature similar to many electronic organs, as well as inclusion of circuits which reproduce popular Hammond/Leslie effects will be found. The performer who needs to obtain some instant commercially viable electronic tone colors, and wants to store a couple of his or her own original ones, will find push button presets. For the synthesist interested in new combinations of voltage-controlled circuits, there are a few novel ways of using the keyboard control capabilities, a ring modulator, and a slightly different way of handling envelope control of the voltage controlled filters.

The CS-80 is an eight voice instrument with two oscillators available for each voice. The oscillators can be treated as separate types of timbres, played together or one at a time, set at different intervals according to traditional organ registration, and oscillator two can be de-tuned from number one by a semi-tone up or down. The instrument has been divided up to reflect the two-oscillator division. There are two identical panels for manual operation of each oscillator, two rows of push buttons (one for each oscillator), two sets of two pre-set controls for program recall, and a series of tone controls, balance, keyboard response, and envelope controls which influence the entire output signal. Beside the two "memory" programs which the musician determines, there are eleven factory presets, and a button which shifts to manual operation for each of the two oscillators. Once the characteristics of the sound have been set for both oscillators and their concomitant voltage controlled filters and amplifiers, any key or keys depressed will produce the same program set. ADSR envelopes control the VCAs for each oscillator set, with volume in and out controllable. High-pass and low-pass filter controls, with resonance amounts for both, make a voltage controlled band pass situation the normal mode of operation when working

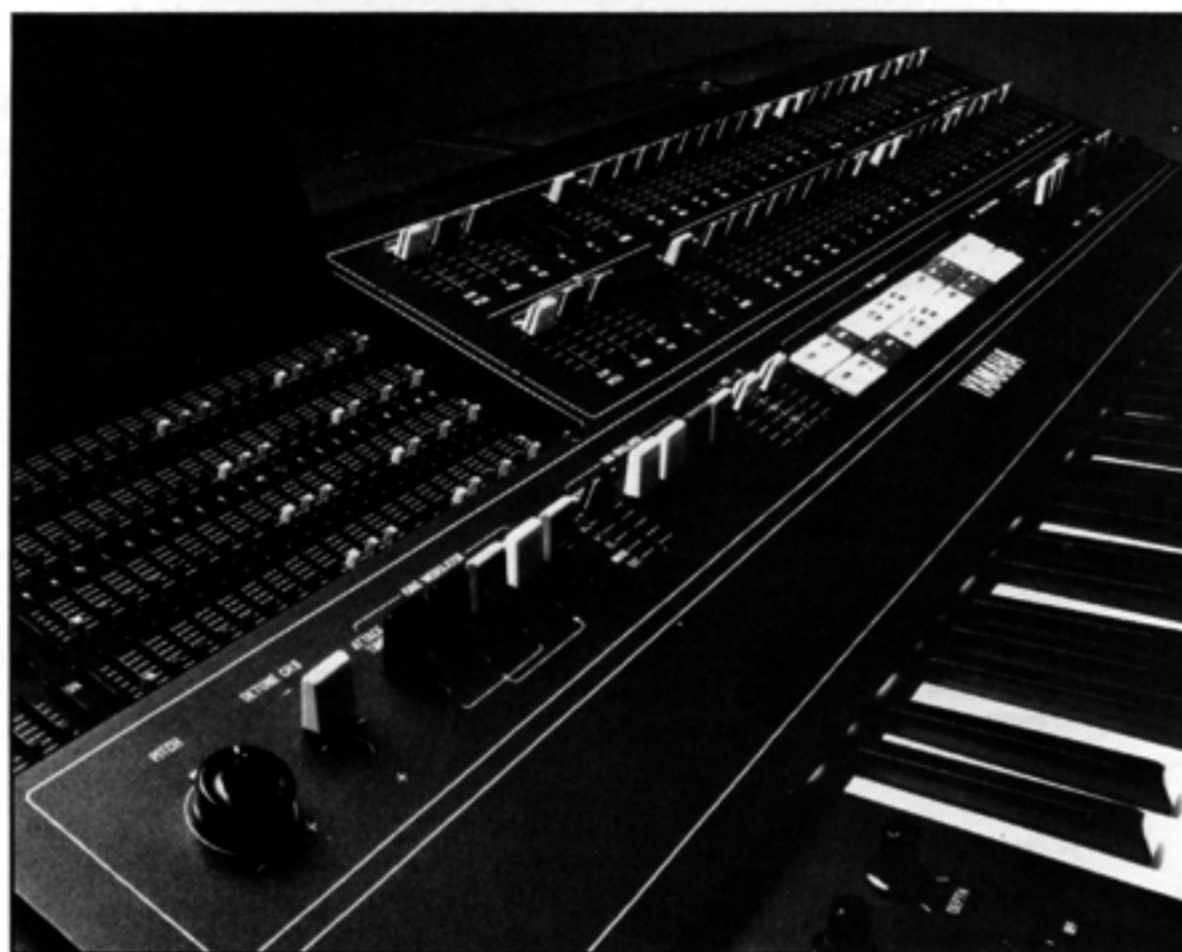

Yamaha CS-80 Polyphonic Synthesizer

with the manual controls of the instrument. The envelope which controls both filters (high and low-pass) simultaneously (with no attenuation of voltage out to each available), is a curious ADR situation where the sustain is determined by the filter sliders themselves. Thus, the envelopes often function as AD controls alone. However, a release time goes into effect as a function of when a key is released. If the instrument has not yet resumed its nominal cut-off points, the release time factor is engaged. An additional slider, the Initial Level control, lowers the initial cut-off point of each filter to achieve a more effective initial attack characteristic. This becomes a very important control when high-pass filtration has deleted much of the impact of the fundamental, and because no independent sustain level is available.

Keyboard control of the CS-80 is its most important asset. Keyboard pressure and velocity can control both volume and timbre. Initial pitch bend, as well as amount of sub-audio oscillator control of pitch, timbre or volume (VCA) modulation are also touch sensitive. All of these functions can be garnered at once. For a keyboard player with good technique, a great many expressive

elements can be achieved.

Further expressive effects are available with a felt ribbon (pitch) controller, with voltage pedal, and with a release pedal which can control envelope release time as well as glissando/portamento engagement. Overall envelope release time can be controlled as well on all presets with a manual slider, as well as overall timbre via brilliance and resonance for the bottom and top of the keyboard.

The advantages of this instrument are inherent in the previous description. This is a keyboard performance instrument, for traditional musical applications, which evidences a tremendous amount of nuance control. Many of these expressive effects have not been available to synthesists outside of the pressure sensitive controllers built first for contemporary music creation by Don Buchla. Overall "brilliance" and resonance control aid the touch sensitivity effects greatly. The instrument is simple to operate for the musician who wants to stick to the basic presets available in the lower center of the instrument. I file under advantages the fact that operation of the instrument from the panel (manual "patching") is somewhat more complex, and thus a small amount of discov-

ery can go on. The addition of Tremolo, Chorus, pulse width modulation on the oscillator panels, and a bit of programmable memory is a definite plus. Don't rely too heavily upon the "programmable" nature of the instrument, however. The memory is not digitally stored, but is rather a series of miniature sliders which reproduce the face of the panel in miniature at the upper left of the instrument. Like earlier Yamaha organs, the musician obtains a desired sound on the regular panel sliders, and then attempts to reproduce the settings, slider for slider, on the miniature version. Punching the "memory" button simply replaces the master panel or presets, for the miniature panel which has been set.

The disadvantages of the CS-80 begin with the fact that programs cannot be "recorded" nor stored as they can with the Oberheim synthesizers, or the Sequential Circuits Prophet. The CS-80 is a step ahead in keyboard control, and a generation behind in digital control. The instrument will have to be updated soon if it is to keep pace with the several fully programmable instruments which are becoming available in the marketplace. A more unfortunate disadvantage to the instrument is the organ-based conceptualization which has guided its development. The ability of a small performance synthesizer to create widely varying timbres and textures is directly proportional to the amount of access points for amplitude modulation, frequency modulation, filter/amplitude modulation, and "cross-talking" circuits of various kinds. The CS-80 is not an open system instrument. External control voltage sources cannot be used without modifying the instrument. Nor can one oscillator modulate the other, as an example of one connection which might produce some widely varying predictable viable results. The instrument simply has a narrower range of basic sounds available to it than do some other instruments currently available. For a musician interested in obtaining a wide selection of electronic sounds for orchestral purposes, this may not be a good choice. For a musician with excellent keyboard facility, who wants an instrument which will greatly enhance his abilities, this is a number one choice. The instrument's potential is really just being discovered.

The Yamaha CS-80 is priced at around \$6900.00, with a suggested tone cabinet at \$600.00 to go with it. At this price, it is the more expensive of the polyphonic instruments, with the exception of the Oberheim eight voice with programmer.

A note of caution about the poly-

phonic synthesizers—all of them. These are all complicated instruments. They all have faults attributed to them rightly or wrongly, due to their newness, production developments, and competition for sales. The demand for these instruments is greater than the supply. This is true for virtually all manufacturers supplying the major sales

centers. It is easy for an instrument to gain a bad reputation due to quickly corrected problems of early production models. This has been true for the Polymoog, the Oberheim, the Yamaha, and the Sequential Circuits Prophet. The CS-80 I use appears to be a very reliable instrument. But I have not had it transported with any frequency yet.

(It takes at least two people to move the CS-80. This is a semi-portable instrument.) Repairs and adjustments to a new instrument must be expected. The service back-up provided by a company the size of Yamaha is a definite asset to take into account when choosing an instrument of this complexity.

—Dan Wyman

The OB-1 is a monophonic, programmable lead synthesizer. It has the same basic modules as most other lead synthesizers, but also contains a programmer which "remembers" up to eight programs. This, for most people, will probably be its most interesting feature.

Billing itself as, "The First Completely Programmable Lead Synthesizer," the OB-1 is not exactly that. Functions which are programmable are: all functions of the VCF (frequency, resonance, modulation, noise, etc.), both ADSR envelope generators, volume, as well as all functions of both VCOs including frequency, waveform, and modulation. One exception to this is the fine tune knobs on the VCO and VCF modules. Non-programmable are the functions of pitch bend, portamento, VCF master frequency, manual volume, and the functions of the LFO (waveform switch, delay and rate of frequency knobs).

Aside from programming, the OB-1 has some other interesting features. The VCOs are quantized for easy tuning, and although smooth control over VCO frequency has been removed one step with this arrangement (the fine tune knobs are not quantized, and subtle pitch variation is controllable from there), this is a real advantage in live performance because of the time it saves. Furthermore, frequency modulation by the LFO is not affected by this quantization.

Another nice touch is the mode switch in the VCF module. The two settings allow for two or four pole frequency cut-off slope, and this makes for a good solid sound, especially on the four pole setting. The inclusion of two ADSR envelopes, one for the VCA and one for the VCF, is also handy. In addition, the VCF envelope can be used for modulation of VCO 2.

The system for bending pitches is extremely effective on the OB-1. Consisting of a lever which can be moved up or down, and springs back to center, it works in conjunc-



Oberheim OB-1 Programmable Synthesizer

tion with two switches located nearby. Pitch bends can be set to range from an octave (Broad) to a major second (Narrow) in either direction. The basic idea behind the lever is such a good one, that it literally invites the player to break out of those old clichéd mannerisms, and be a little more creative with pitch bending. The two switches can also be used in conjunction with the lever for special effects: bringing in noise, bending just one oscillator, and adding FM. The overall sound of the OB-1 is solid and full.

There are a few drawbacks, however. The modulation knobs in the VCO modules are adjusted to encompass such a great frequency width, that achieving smooth, even FM is a matter of millimeters; and since FM occurs so early in the knob's rotation, the rest of the range is unusable, for this purpose at least. Moreover, since the LFO

is non-programmable, the rate of FM must be adjusted every time it is being used—a little inconvenient, since the only way to judge the rate is by listening. An LED would be a good idea here . . .

One more aspect which makes the programmer a bit tricky to use is the fact that the fine tune knobs are non-programmable. This means that when you recall a program, the fine tune knobs on the synthesizer had better be identically aligned, or your program will be very out of tune—unless it was recorded with the oscillators sync'd, in which case, you may not even notice the small timbral difference. Same goes for the VCF fine tune.

The only other complaint I have is the method of programming with touch-sensitive buttons. They don't always activate to program when they are touched. I was informed by Oberheim that this is a ground-

ing problem which can be solved by simultaneously touching part of the chassis while programming. This seems like an unnecessary variable to have to deal with. Also, because of the touch-sensitive nature of the buttons, it is easy to inadvertently erase an old program while writing a new one. Programming is such a great idea for the live performer, that it is a bit of a waste to do it this way instead of using switches, for example, which are more dependable, and certainly more difficult to trip by accident.

Just the same, the OB-1 does what it's supposed to. The sound is solid, it is set up logically for the mind, and clearly for the eye (except for the black switches which are likely to be invisible in the dark), and is very light and portable.

External access jacks on the back are: Audio In, CV In and Out, Gate In and Out, VCF pedal, Loudness and Audio Out (low and high levels), as well as an Input/Output for cassette interface, and an Input for program select.

—Melodie Bryant

Errata: Synapse apologizes to **Star Instruments, Inc.** for a choice of words that may have misrepresented the intention of last issue's review of the Synare 3 percussion synthesizer. In concluding it was noted that because of the oscillators not being voltage controlled and there being no patching or interface ports available, that "the Synare 3 becomes not much more than a toy." We did not mean to infer that the instrument is not manufactured in a professional manner or is not suited for professional use. The instrument is indeed reputable but does not allow, without altering of the circuit board, inputs or outputs that would increase its capabilities as a synthesizer. ● In last issue's review of the **Sequential Circuits Prophet**, Synapse mistakenly credited the chips used for the instrument's oscillators, filters and envelopes to E-mu Systems. The proper credit belongs to **Sold State Music**. Our apologies.

GUITAR SYNTHESIS

The ARP Avatar Guitar Synthesizer is essentially an ARP Odyssey keyboard synthesizer with a guitar interface unit replacing the keyboard and its associated interface electronics. The Avatar is sold as a stand-alone unit, complete with a hexaphonic pick-up to be mounted appropriately on the user's own guitar. (List: \$2499.00)

The synthesizer section of the Avatar has the standard modules for producing single-voiced monophonic melodies or harmonies: two VCOs, one VCF, one VCA, one LFO, one S/H unit, and two envelope generators (ADSR and AR).

An additional control voltage is derived in the guitar interface sections. It is termed the envelope follower (EF CV). It produces an envelope-style control voltage whose depth, and to some degree shape, are proportional to the loudness of the last string's audio signal. The general shape of the EF CV is similar to that of an AD envelope generator. The Avatar allows this control voltage, or its inverted image, to be applied to the VCF and/or VCO 2. When applied positively to the VCF, the resonance can be adjusted to yield the customary envelope follower/filter sound (Mutron, et al.)

Another additional by-product of the interface section is the Hexaphonic Fuzz (Hex Fuzz). This fuzz is produced by fuzzing each string independently, and then mixing the signals. This procedure produces a 'clean' fuzz which can be mixed directly out (entirely bypassing the synthesizer section), and/or mixed into the VCF along with the VCOs.

In my use of the Avatar, I have come across several facts not clear in any preliminary clinical description such as my description thus far. Externally, the Avatar offers guitar players the important convenient aspect of a one cable and one box unit. The casing is industrial grade (a necessity for road usage), and the internal circuitry is mounted very securely. My personal feelings toward the guitar interface section however, are mixed.

The actual Pitch-to-Voltage (P/V) converter works well enough for live performance when the pickup has been positioned properly and the individual trimpots have been time-consumingly calibrated. Unfortunately, there are occasional 'glitches' which make recording use of the Avatar very limiting. The calibration technique given by ARP is also very rough and very, very subjective. Too many functions are being calibrated off each of these trimpots, and I consider this problem to be one of the major drawbacks to the Avatar. These trimpots must compensate for bridge curvature, differences between the individual signal strengths, Envelope Follower sensitivities, triggering sensitivities, the tone of the clean guitar/Hex Fuzz for each string, and to a large degree, the amount of sustain available on a held note. Of course, all of these things vary from guitar to guitar, but inevitably some tradeoffs are bound to

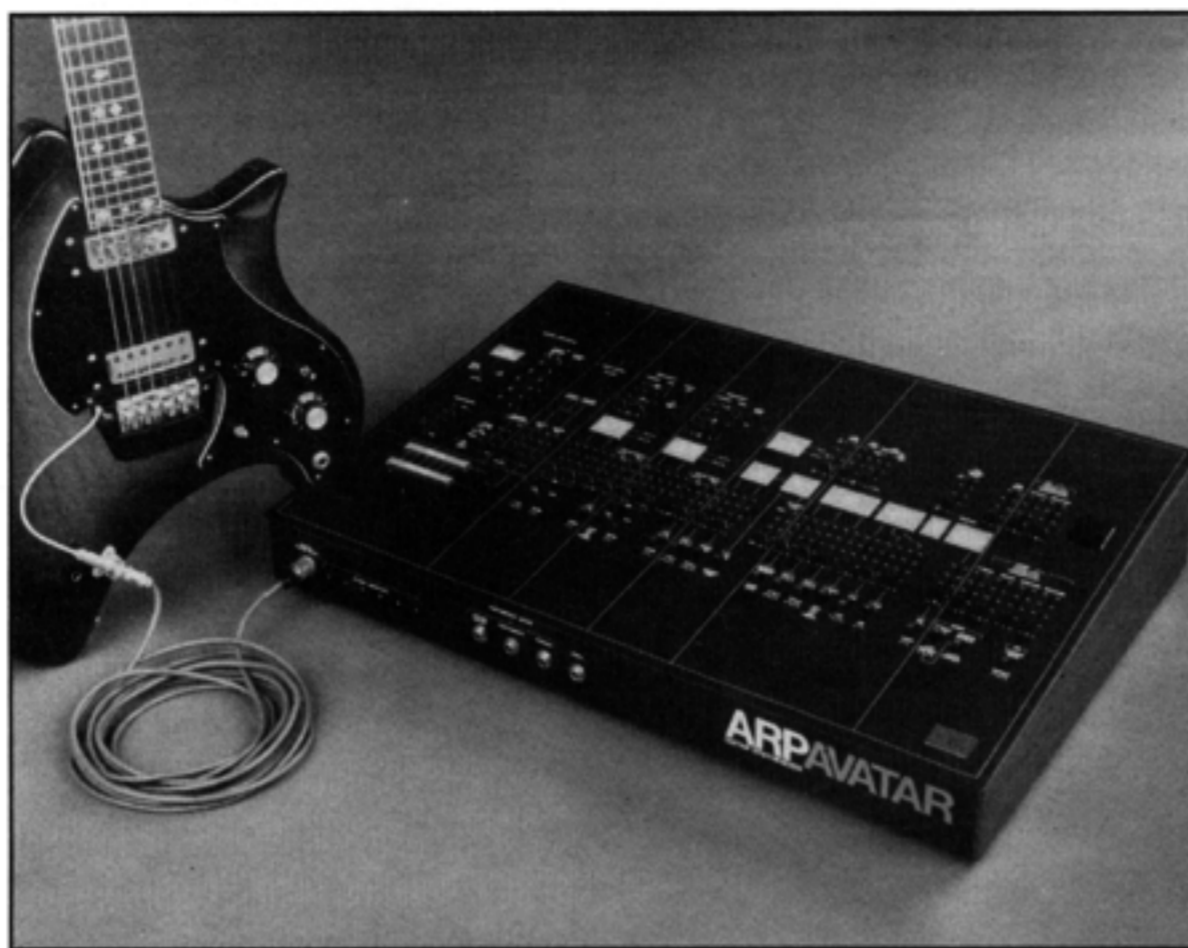

ARP Avatar Guitar Synthesizer

be made. A possible solution is the development of a system where the pickup has adjustable poles and the Avatar has LEDs or some other indicator to tell the user when the optimal position has been achieved. Perhaps a single sensitivity control for the Envelope Followers could be offered on the front panel so that the user could adjust this all-important CV to their personal picking style and taste. This type of overall sensitivity is already offered for the triggering mechanism.

It should be noted that holding a note for too long is risky. As the signal dies away, the P/V can 'hear' the noise in the signal and it gets confused and outputs random notes. If you know you're going to hold a note for a long period of time, you should use the Sustain footswitch.

I personally believe that this sustain function could have been implemented in a better fashion. As it behaves now, its function is to hold the VCOs and to keep the gate on. However, it also eliminates the use of the Envelope Followers and blocks the triggering mechanisms. So it behaves more like lockjaw for your synthesizer. It also does not function at all when the Avatar is being controlled from an external source (through the control inputs on the back panel). I believe that it would have been much more useful if it had sampled the 'String CV' just before it gets applied to the VCOs. Then a switch could have been added to lock either one VCO or both. This would then allow for four synthesizer functions to be applied to

one VCO while the other was being held as a drone. The footswitch would also then function on external control voltages.

Another annoying limitation of the Avatar is the option to use either the Envelope Follower CVs or the Pedal Controller. When a person is playing a guitar, both hands are occupied so the amount of real-time control is much more restricted when compared to the power of the left hand of a keyboard player. My point is that while you are playing you can't control very much; pitch and either the Envelope Followers or Pedal in the case of the Avatar. In terms of getting control to the user this is a real drawback. I might also point out the fact that there is no way to apply the Envelope Followers to the VCA. This would have offered guitar players a function consistent with guitar playing. That is: plucking harder makes louder notes. In other terms: convenient dynamic control.

The next set of complaints stem from the fact that ARP basically only designed a Guitar Interface section and linked it to their best middle-priced synthesizer (with a few trivial modifications). This cannibalistic approach to the design of a synthesizer leaves, to my ears, a great deal to be desired.

The lack of any octave switching on the VCOs makes tuning the Avatar a time-consuming task and almost eliminates this option from live performance situations. Octave switching had been available on the Odyssey on the front panel area but this was replaced by the

Guitar Interface section.

One of the 'standard' applications for a sample and hold unit (S/H) is to use it as a harmonic accent controller for a VCF. Using an LFO to trigger the S/H generates rhythmic figures whose overall tempo corresponds to the speed of the LFO. Similarly, an LFO can be used to churn a VCF much in the way phase shifters, flangers, tremolo and auto-pan units can be made to turn in a cyclic fashion. ARP has eliminated the availability of these effects in the Avatar; unless the player wishes to play only on the 'beats' of the LFO. The problem is that the LFO has been set to start fresh cycles on each new trigger derived from plucking. (Yes, this is the same concept described as hard sync. In this case, the LFO is being synched to you, the player and if you don't play in a periodic fashion, a random sync fundamental is generated). I have been told by an engineer that a switch could have been put in, at almost no cost, to either sync the LFO to you or not. Among other applications, a synched LFO makes for a more expectable vibrato.

I also find the low frequency/string off position of the switch on VCO1 to be of little use. On the Odyssey, VCO1 could be used for modulation (audio or low freq.) by using the S/H Mix CV which was available. Without this S/H Mix CV, the low frequency position seems much less useful. Without this S/H Mix CV, the S/H unit also has other limitations. VCO1 and VCO2 can no longer modulate each other, and sampling the audio pulse waves of the two VCOs produces a random bistable control voltage at best. Instead of wasting two of the four inputs to the S/H in this way, perhaps sampling an ADSR or an AR or an Envelope Follower might have yielded more useful musical applications.

It should be noted that ARP has made available a Custom Engineering Group for getting modifications done to your synthesizers. The address is ARP Custom Engineering Group, 45 Hartwell Avenue, Lexington, MA 02173. They do of course charge for this service, but then your warranty is not voided. Many modifications are straightforward enough that finding a nearby musical engineer can save time, money, and will allow more distinct and specific modifications (ARP has 15 different modifications and they only apply to various ARP synthesizers).

In answer to a request for my favorite patches, I have included some interesting starting points. I understand that ARP distributes a primer of fundamental patches and a demo tape, but I have not seen either one so please forgive any duplications. I am also interested in any interesting results from using these patches.

For practicing or for beginners, I would suggest setting both Attacks to zero, both Decays to about 1/3, apply

Continued on page 43

Synapse Book & Record Mail Order Service

A collection of familiar and hard to find titles is now available through Synapse. If you're interested in obtaining any books, records, films, or videotapes not listed here, let us know. We may be able to include them in future catalogues. **To order, follow these simple instructions:** List the title, order number and price of each item you want. Deduct 10% discount for any order of three or more items. California residents add 6% sales tax. There are no additional shipping charges for orders within the US. Shipping charges for orders originating outside the US are as follows: Antigua, Argentina, Canada, Columbia, Costa Rica, Mexico, Saint Lucia add \$1.00 per item ordered. Argentina, Austria, Belgium, Brazil, Denmark, Finland, France, West Germany, United Kingdom, Greece, Ireland, Italy, Luxemborg, Netherlands, Norway, Poland, Portugal, Spain, Sweden, Switzerland add \$2.00 per item ordered. Australia, People's Republic of China, Hong Kong, India, Japan, New Zealand, and all other countries add \$3.00 per item ordered. All orders must be prepaid in US funds. Send your check or money order payable to Synapse to: **Synapse Mail Order Service, 1052 West Sixth Street, Suite 424, Los Angeles, CA 90017. Allow 3 to 6 weeks for delivery.**

Books

Electronic Projects for Musicians by Craig Anderton

#101 A pragmatic text that makes no presumptions about your electronic prowess. All subjects from basic theory to tool and components, to construction methods, to finding parts at a reasonable price, to trouble shooting and repairing circuits, are covered thoroughly and simply with excellent illustrations by Vesta Copestakes. Nineteen projects include Compressor, Ring Modulator, Eight In One Out Mixer, Dual Tone Filter, Electronic Foot-switch System, Nine-Volt Adaptor; all completely illustrated with step by step directions for construction, and notes on packaging and applications. Forward by Joe Walsh. 134 pages plus sound sheet. 8½" by 11" paperback. #101 \$7.95

Home Recording for Musicians by Craig Anderton

#102 A no-nonsense waltz through the complications of recording music. Everything you need to know to get an intelligent start in home recording is covered point by point, and not just the hardware. Sections on the combined role of producer/engineer/musician, shopping demos to record companies, and reference materials and sources round out the scope. Also included is a section on building your own mixer. Forward by George Martin, illustrations by Vesta Copestakes. 184 pages plus sound sheet. 8½" by 11" paperback. #102 \$9.95

The Evolution of Electronic Music by David Ernst

#103 A thorough history of electronic music from World War II through the first half of 1976 organized by sound sources and compositional techniques. Each section is followed by a discography covering both popular and avant garde forms of music. An extensive chronology, ample illustrations and Ernst's inclusion of all forms of music make this an important book for anyone interested in music. 256 pages. 5½" by 8½" paperback. #103 \$8.95

Electronic Music Systems, Techniques, and Controls by Allen Strange

#104 A classic on all aspects of making electronic music. Covers signal generation, processing, and control as well as

tape techniques and performance techniques. The text is well illustrated and an extensive bibliography is included that is still unequaled in scope. 160 pages. 8½" by 11" paperback. #104 \$9.25

Complete Guitar Repair by Hideo Kamimoto

#105 An impressive work on the repair, construction, and maintenance of both electric and acoustic guitars. Loads of photos and illustrations about every aspect of guitar construction. 160 pages. 8½" by 11" paperback. #105 \$6.95

Records

David Behrman On The Other Ocean /Figure In A Clearing

#1001 Interactive computer and instrumental music. Computers, analog electronics, and live instrumentalists interact to produce two beautiful "drone" pieces. The computer plays harmonic and rhythmic configurations according to the instrument's input and the players are in turn affected by the computer's response. 33-1/3 rpm lp. 42' 42". #1001 \$6.98

"Blue" Gene Tyranny Out Of The Blue

#1002 An interesting mixture of pop, new music, and lyrical content designed for the ambiguities of the times. Ranging from tongue in cheek to tongue out of mouth, the album is representative of a new combining of musical styles once thought to be incompatible. 33-1/3 rpm lp. 48' 30". #1002 \$6.98

Robert Ashley Private Parts

#1003 The latest from one of America's special composers. Monotone readings by Ashley are backed by "Blue" Gene Tyranny on keyboards. Introspective. 33-1/3 rpm lp. 45' 28". #1003 \$6.98

Peter Gordon Star Jaws

#1004 Pop with a twist. Another entry into the space between chance music and dance music. Co-produced by "Blue" Gene Tyranny and filled with Peter Gordon's multi-tracked saxes. 33-1/3 rpm lp. 37' 29". #1004 \$6.98

Meredith Monk Key

#1005 Amazing vocal performance by Monk with minimal instrumental background. A unique musical theatre piece with strong world music influence. One

of the most unusual vocal performances in contemporary music. 33-1/3 rpm lp. 36' 46". #1005 \$6.98

Jon Hassell Vernal Equinox

#1006 Exotic settings for processed trumpet, using Buchla, Serge Modular Music, and ARP synthesizers. 33-1/3 rpm lp. 50' 23" #1006 \$6.98

Suicide Suicide

#1007 New Wave from New York with vocals and synthesizers. You'll like it so much it will kill you. 33-1/3 rpm lp. 31' 11" #1007 \$5.98

Robert Ceely

Instrumental and Electronic Music

#1008 Five pieces by this Boston area composer and founder of the first Boston area electronic music studio, BEEP, in 1965. 33-1/3 rpm lp. #1008 \$5.98

Far East Family Band Tenkujin

#1009 Japan's premier progressive rock group in the European tradition. Long and echoed anthems. 33-1/3 rpm lp. 33' 44". #1009 \$7.98

Sensations Fix Vision's Fugitives

#1010 Italian progressive rock. The band says of their work: "Inducted music to reach your magnetic field of sensations with irrational thoughts and pure emotions." 33-1/3 rpm lp. 42' 11". #1010 \$7.98

Chronicle . . . Like a Message From The Stars

#1011 A Japanese group formed and recorded in California though living in Japan. A mixture of terrestrial and extraterrestrial with the Jefferson Airplane's vocal style sprinkled in. A spin-off of the Far East Family Band. 33-1/3 rpm lp. 40' 17". #1011 \$7.98

Gregory Allan Fitzpatrick Bildcirkus

#1012 Fresh and original music from Sweden. Too varied to be classified and too good to be missed. You'll love the cover fold out—it's like being a kid again. 33-1/3 rpm lp with special cover. 42' 33". Swedish import. #1012 \$6.98

Don Slepian in co-operation with the members of the Hawaii Electronic Music Group Electronic Music From The Rainbow Isle

#1013 Seven years of electronic music from one of Hawaii's most active young composers with help from HEMG, Hawaii's stronghold of electronic music

activity. The tip of the iceberg of music that we have never had a chance to hear. Cassette 32' 30". Dolby System. #1013 \$6.00

LEM Machines

#1014 Los Angeles audiences saw this group live prior to their break-up, and this is their first and only album. Styles range from progressive rock to esoteric. Produced by Bryce Robbley. 33-1/3 rpm lp. 42' 20". #1014 \$6.98

Joan La Barbara

Voice is the Original Instrument

#1015 A live recording by one of the most versatile vocalists around. Shares more with electronic music than vocal tradition. 33-1/3 rpm lp. 31' 39". #1015 \$6.98

Bruce Ditmas Yellow

#1016 Melodic and percussive synthesis is combined with Joan La Barbara, voice, and Enrico Rava, trumpet. 33-1/3 rpm lp. 37' 14". #1016 \$6.98

Far East Family Band Nipponjin

#1017 Classic Japanese import by premier progressive rock group.

Parallel World

#1018 Produced, recorded, and mixed by Klaus Schulze.

"The Cave" Down To The Earth

#1019 The last in a trio of imported Far East Family Band. 33-1/3 rpm lp. Japanese import. #1017 #1018 #1019 \$12.50 Each

Temple City Kazoo Orchestra Some Kazoos

#1020 Masterful performances of "2001 Sprach Kazoostra," "Stayin' Alive," "Miss You" and "Whole Lotta Love". The best kazoorchestra album available. 12 inch 45 rpm ep. #1020 \$4.98

Various Artists Rhino Royale

#1021 A sampler of eight Rhino Records acts including Gefilte Joe and The Fish, Wild Man Fischer, Fred Blassie and Little Stevie Weingold. This record will set you straight if you think Iowa still grows the best corn. 33-1/3 rpm lp. #1021 \$7.98

Jasun Martz and the Neoteric Orchestra Pillory

#1022 Orchestra and synthesizers are combined in this album-length piece. Featured are Ruth Underwood and Eddie Jobson. Pressed on crystal vinyl. 33-1/3 rpm lp. 45' 45". #1022 \$7.98

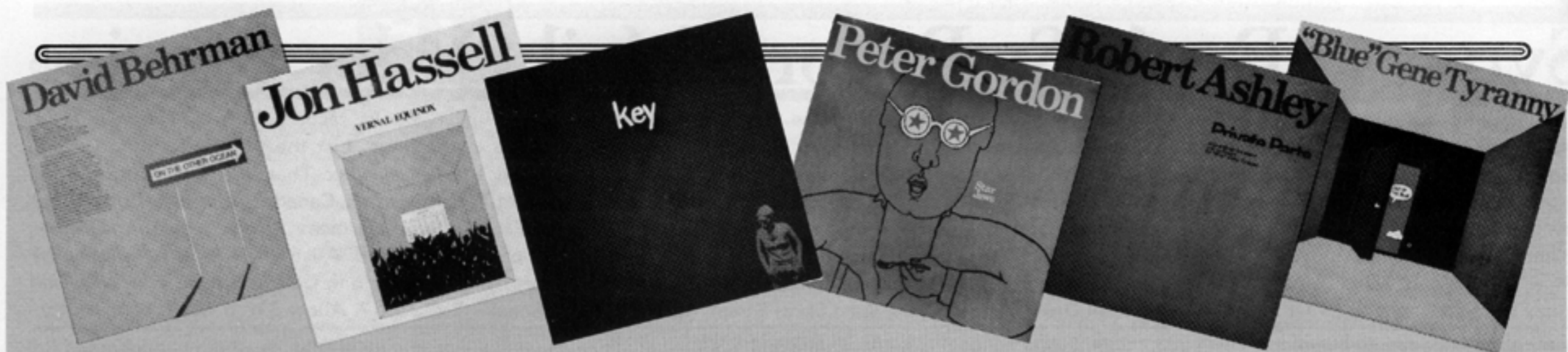

Unlike in the 1960s, when every major recording label had its contemporary or new music series, we now find that the majority of the most adventurous recordings are being produced privately. Typical of this trend is the emergence of Lovely Music, Ltd., something of a microcosm of contemporary music recording.

The number of independent releases grows daily, with progressive composers and musicians producing their own recordings and distributing them as best they can (see Magic Moe's "Survival Notes" from Vol. 2 No. 5). Of all these independent projects, Lovely Music seems to be the year's most ambitious. Their first series consists of six releases: Robert Ashley, David Behrman, Peter Gordon, Jon Hassell, Meredith Monk, and "Blue" Gene Tyranny. Six more are planned for the fall (Jacques Bequart, Rhys Chatham, Gordon Mumma, Tom Johnson, Alvin Lucier and Phil Niblock) with a Jill Krosen release coming before next spring.

The origins of the label are closely tied up with Performing Artservices in New York. This is a non-profit corporation which acts as agent/manager for many new music, dance and theatre artists, including arranging tours and handling the administrative side of other non-profit corporations formed by the artists. These include The Sonic Arts Union, The Philip Glass Ensemble, and Lovely Music, a project of Artservices' director, Mimi Johnson. Her aim was to aid her friends by managing the distribution and other merchandising problems of independently produced recordings. It was thought advisable to have a professional service to relieve the artist of the tiresome work of distribution, advertising and mailings.

Lovely Music and the composers have an arrangement whereby production and marketing are separated. Recording and first pressing costs are paid by each composer, whereas distribution and the cost of successive pressings are the responsibility of the record company. Mimi says that the demand for the records has been steady, and she expects an initial yearly sale of at least 1000 copies of each record. She claims that a large recording company will ultimately sell no more records than Lovely Music, the difference being that a major firm would expect to turn over this many discs in just a few months.

THE LOVELY MUSIC SERIES New Music, New Label

The current series of six releases reflects a wide spectrum of today's music. While the music of Peter Gordon and "Blue" Gene Tyranny has strong rock elements, David Behrman's rich work using a Kim-1 mini-computer and improvising musicians represents a more technocratic approach. Trumpeter Jon Hassell brings African-flavored percussion to music already influenced by jazz and electronics, and Meredith Monk and Robert Ashley both blend theatrical and literary arts with their music to create new unities.

The most obviously funk-influenced of the six is Peter Gordon's **Star Jaws**, which manages to parade the influences of Chicago Blues and heavy rock 'n' roll, while at the same time including traces of Terry Riley, Steve Reich and Phil Glass. The common essence of all these influences is that the music is minimal in several parameters, and Gordon uses this to create rich instrumental textures of compelling rhythm. He also keeps his voice minimal, especially on "Life is Boring," where it is relentlessly dry, almost strained. The instrumentals have a very loose "feel," especially "Machomusic," the best cut, which drives along like an unstoppable solid chrome semi-, careening through the Utah flats at 4 a.m.: four percussive tenor saxes in a constant lung-pounding dance 'til dawn.

"Blue" Gene Tyranny's **Out of the Blue** draws on more fluid jazz and "San Francisco" rock influences. The vocals often express gentle, tender sentiments, and a concern with planetary awareness. Such thoughts are often awkward, and this feeling is heightened musically by lines that tend to run on too long, or by suspended rhythms. The title track, "Out of the Blue/A Letter From Home About Sound and Consciousness," (similar of course to ELO's last album title, but "Blue" Gene claims that both were named at the same time), along with "Leading a Double Life," are the most lyrical cuts on the recording. Both feature delicate harmonic material drawing on

French, German, Rag and "Blue" keyboard traditions. "Next Time Might be Your Time" is a catchy "new age" love song. Throughout the album "Blue"'s Polymoog work is masterfully luxurious and fluent.

Jon Hassell's **Vernal Equinox** is much more African in orientation, but like "Blue" and Peter Gordon he is largely interested in more immediately accessible music than that usually termed "new music." He features imaginative trumpet lines, perhaps improvised, over various percussive, electronic or environmental drones. The trumpet's clicks and curls are filled with novel and engaging turns. On two cuts, for example, David Rosenboom alters the trumpet with a Buchla synthesizer system, while on "Viva Shona" he is joined by Hassell on Fender Rhodes, with Arp synthesizer alterations by Andy Jerison. Serge synthesizer and Motorola Scalatron provide drones for the other cuts. The opening track, "Toucan Ocean," has a drone of shakers (possibly pods of dried beans) mixed with constant, though sensitive and gentle, congas. The Buchla processing lightly alters the trumpet's timbre, giving a rounded bubble to the sound. In all, this is an eminently likeable recording.

State-of-the-art mini-computer electronics is represented by composer/designer David Behrman. He maintains an active performing career, often performing with the Merce Cunningham Company, and has been a visiting professor at the Center for Contemporary Music at Mills College, where Robert Ashley is director. At least part of four of the recordings was done there. The two pieces here are both intended for live performance with electronics. In "Figure in a Clearing," the title track, the computer is programmed to control the harmonic and rhythmic settings of 16 triangle wave generators provided for the soloist. Mixed with these are 16 additional triangle wave generators and one sine wave drone. The program for the rhythm is modelled on the continuously fluctuating velocity of "A

satellite in falling elliptical orbit about a planet." The soloist is cellist David Gibson, who improvises delicately with this subtle texture.

"On the Other Ocean" is David Behrman's most recent solution to the problem of building electronics which are sensitive to the sounds of live performers. This is a live recording of an improvisation by Maggi Payne, flute; Arthur Stidole, bassoon; and Kim-1, harmonic responses. Pitch sensing circuits activate the "interrupt" line and input ports of the Kim-1, and determine harmonic changes in the two homemade music synthesizers. In this case the electronic sounds take wide gaping leaps and bounds, whereas before the motion was step-like and abrupt. Although each piece exceeds 20 minutes and the timbral changes are few, the effect could easily sustain interest for an hour in live performance.

The two remaining records synthesize various art disciplines in a way that could be called 'multi-media,' although not in a completely pure form. Meredith Monk's **Key** is called "invisible theatre," music in a stark, minimal presentation. There are elements, like footfalls and other stage sounds, that add an almost naturalistic element, but much of the piece is built on Meredith's astounding voice. It includes elements of Japanese, American Indian, Semitic and extended vocal practices. The blend is so unique and refined that people unfamiliar with vocal work of this nature have an exciting work to explore.

Private Parts, Robert Ashley's cinematographic recording, contains two songs or poems with music: "The Park" and "The Backyard." Ashley narrates his own visually evocative text, and in all, the work is the most developed, experimental, and yet warmly familiar work of the series. Somehow, without direct reference to any popular music forms such as rock or jazz, without any overt nod to contemporary folk music, Ashley has pointed the way to a music of great beauty and potentially wide appeal.

These two pieces were recently performed, with another song, by Ashley and "Blue" Gene Tyranny at the Kitchen Center for Video and Music (59 Wooster St, NYC 10012). These are the first three pieces in a seven song cycle and it will be interesting to observe the developing progress of this major opus.

—Bob Davis

From page 17

electric chair for the ultimate rush in voltage control. (He was finally shot.) In this excellent work, interpretation through timbre and mood have been substituted for the "razzle-dazzle" keyboard work found on most electronic music discs.

Of course, the whole subject of Gilmore is a somber story, and Garvey's interpretation portrays the man as the ultimate in sadness and loneliness. If your fancy is upbeat boogie or "ishco-dishco," don't purchase this album because it creates a very low-key feeling which describes Gilmore perfectly.

The program notes for the album include a quote by Gilmore which Garvey used as a basis for structure. "You

that kind of a dream. But I think someone like him, who was a very sensitive person, his mind got at some of the real essential forces that happen to be the architectural-sociological environments that we exist in. It's more intense in prison, but it also exists in a city wherever you go," said Garvey.

Not only does this album excel in interpretation, but it proves that Garvey has discovered what this reviewer feels is the secret of electronic music composition. This secret is the use of some kind of foundation on which to build synthesized sounds. In *Labyrinth*, his basis for continuity and structural flow is the use of drones, sequencer ostinatos, and rhythmical "booms." Without these foundational devices, this piece would have taken the unstructured and garbled path of incoherence that so many avant-garde electronic works have in the past.

Labyrinth is divided into seven sections: "Origin," "Capture," "Abyss," "Soweto," "Inside," "Cosmic Relief," and "Escape." "Origin" is interesting because it comes closer to song form and tonality than any other section, but it still falls short of sounding commercial. Considering that this section described Gilmore's life before the problems entered, it becomes apparent that **he just wasn't having a good time.** "Origin" could pass for a twentieth century funeral march. A minor mode is used for the slow-moving haunting melodic line, while a sequencer pattern is filtered throughout the piece.

The timbres that Garvey generates in the "Soweto" section are on an equal level with Tomita's. The atmosphere created here is totally sinister. It's a sound grim enough to make Black Sabbath sound like Sesame Street.

The remaining five sections are all spacial sounding pieces that show a fine creativeness for texture and timbre. These sections can be a total experience when listened to in the best musical environment Mother Nature can provide.

Now, before I get to the negative things, let me mention that this album can be had for \$5.50 from Frank Garvey

Synergy Cords Passport PB 6000.

Jean-Luc Ponty *Cosmic Messenger* Atlantic SD 19189.

Phil Manzanera *801 Live* Polydor PD-1-6148.

George Duke *Don't Let Go* Epic JE 35366.

Idil Biret *New Line Piano* Finnadar SR 9021.

Frank Garvey *Labyrinth* Warp Records, Omega Intermedia Center, 3433 N. Halsted, Chicago, IL 60657.

Cellutron & The Invisible *Reflecting on the First Watch* Green Mountain Records, Northfield, VT 05643 GMS 4015.

Dennis Garcia *Jive To Stay Alive* Indigo/Seabird DG/IN 001 c/o Graeme McKee Management, P.O. Box 286, Milsons Point, N.S.W. 2061, Australia.

Steve Maxwell von Braund *Monster Planet* Clear Light of Jupiter CLOJ-777. 609/343 Little Collins St., Melbourne, 3000, Australia. Or, Suite 500, 396-400 Kent St., Sydney, 2000, Australia.

Cybotron *Cybotron* Clear Light of Jupiter CLOJ 782.

Cybotron *Colossus* Champagne Records CHA 7004. 2/609 St. Kilda Rd., Melbourne, 3004, Australia.

Suicide *Suicide* Red Star Records RS1.

Jasun Martz & The Neoteric Orchestra *The Pillory* All Ears Records AE 11480.

Yes *Tormato* Atlantic SD 19202

Various Artists *Airwaves* One Ten OT 001/2

Steve Reich *Music for 18 Musicians* ECM 1-1129

David Bowie *Stage* RCA CPL2-2913

The Jeff Lorber Fusion *Soft Space* Inner City IC 1056

Jon Appleton *Music for Synclavier and other Digital Systems* Folkways FTS 33445

Bulent Arel & Daria Semegen *Electronic Music for Dance* Finnadar SR 9020

Peter Gabriel *Peter Gabriel* Atlantic SD 19181

Be-Bop Deluxe *The Best of And the Rest of Be-Bop Deluxe* Capitol SKBO-11870

c/o Omega Intermedia Center, 3433 N. Halsted, Chicago, IL 60657. Look at it this way—the cash goes into the composer's next album, instead of some cigar chomping record executive's pocket.

Even in my meanest mood, all I could complain about on this album is the length. Its forty-nine minutes should be ungrooved to about thirty-five. There's no need to modulate us patient admirers for the electronic craft over the head with it.

Since most of today's synthesists are keyboard players, I think the album's unique and original feeling stems from the fact that the composer is a drummer by trade. I strongly recommend this album to the serious synthesist. Garvey has a great knack for panning and mixing. The album's technical quality is near perfect considering it wasn't mastered at a one-zillion track studio with more toys to play with than a spoiled brat has on Christmas morning.

—John Parris Frantz



Blue Mute No. 32646

hear that goddamn pounding? I used to dream that I was being led to this place that had a wall with slots in it, like lockers, and they would open one of 'em, and it was all concrete and dirty, and they would slide you in there. I had that fuckin' dream about a dozen times."

Although Gilmore's experience may appear like a strange realization, Garvey explains why he used it for his album. "I did some sculptures that looked just like that dream before I ever read the dream, so I was really into that kind of an idea. I saw his dream, and that is a documented dream. I thought it really got at some of the underlying forces that are around today. You don't have to be in prison to have

Arp Avatar

From page 40

the ADSR to the VCF and the AR to the VCA. Tune both VCOs to unison, sync them, and apply a bit of the +EF CV to both the VCF and VCO2. Throw in a dash of Portamento, and go. This patch offers a very standardized Avatar sound, with the ability to 'feel' the +EF CV and get used to the way the Avatar triggers.

Lowering VCO1 one octave, mixing in some Ring Mod, inverting the EF CV (no longer applying it to VCO2), and shortening the ADSR serves as a nice plucked lead tone.

There are many good 'bass' sounds,

and they all involve lowering both VCOs and unsyncing them. Closing down the VCF pretty much smooths off the bite and adding a little LFO vibrato can make a little more 'rubbery' sound.

As an additional lead sound, I have used VCO1 tuned down 2 octaves, and VCO2 down one, unsynced. Adjust the control range for the pedal on VCO2 to an octave, and setting the initial setting for the VCF so that it's relatively closed down with the pedal in the zero position (back) and somewhat open in the forward position. When a lot of Ring Mod is used, this patch yields two basic sounds. With the pedal back, a subdued 'bassy' sound, and with the pedal forward, a ripping lead ring sound. Varying the pedal near the high end yields a distortion-feedback-pitch bend

sound which I find very Hendrix-like in character and texture.

For those of us who like chords, I have found that setting VCO1 down an octave, and VCO2 down an octave and a fourth, and mixing them each at 50% with the full internal Hex Fuzz and 25% outside Hex Fuzz, yields a pseudo-synthetic chord sound. The ADSR to the VCF should be set to taste, and the VCA gain should be set at about 30% with the AR applied about 80%.

I might also add that since most guitar players who are interested in synthesis have probably got a load of 'boxes,' these can be used with the Avatar by coming in the External Input jack on the back panel. I use the guitar out, go through my 'boxes' and back into the Avatar. If an echo or other delay

unit (even reverb) is somewhere in the line (this pseudo send-return line) the results can be quite spectacular. For instance, as the Avatar envelopes open, you hear the delay (space), and as they close you come back to dry again.

I sincerely hope that ARP does not feel as if they have been put on the chopping block alone. Most of my complaints apply to the other guitar synthesizer makers too. Feedback is what shapes and improves next year's model. Special thanks to Dave Torn for his invaluable assistance. —Buzz Kettles

© 1978 Buzz Kettles. This article will also appear in *Device*, the monthly newsletter for the electronic guitarist/musician. Annual subscriptions are available for \$15.00 from Device, P.O. Box C, Carmichael, CA 95608.

COMPUTERS

Computer Languages

The subjects covered in this column up to now have been on the electrical interface aspects of connecting a computer to a synthesizer. The computer itself has been treated as a "black box," with all of the attention paid to the inputs and outputs which are modified before being connected to a synthesizer. Once all of the hardware aspects of these interconnections are made, the computer is ready to perform whatever task the programmer wishes—within the constraints of its interconnection to the synthesizer. The programmer is now confronted with the problem of telling the computer what to do. This is where we enter a whole new area called software.

Software is the collection of programming languages, and the programs written in these languages, which instruct a computer to do a given task. Software is called software because it is an easily changeable part of a computer system in contrast with hardware, which refers to the computer electronics which are less easily changeable. When a programmer wishes to instruct the computer what to do, he writes a software program. This program is an orderly sequence of operations which a computer can perform. The sum total of these operations is what the programmer wanted. A programmer can sit down at the console of a computer and issue the instruction, "Play a scale." This is not a single command, but rather a referral to a program comprised of operations the computer can do which, when complete, will produce a scale.

The communications procedure between the programmer and the computer must be done in a medium both understand. This medium of

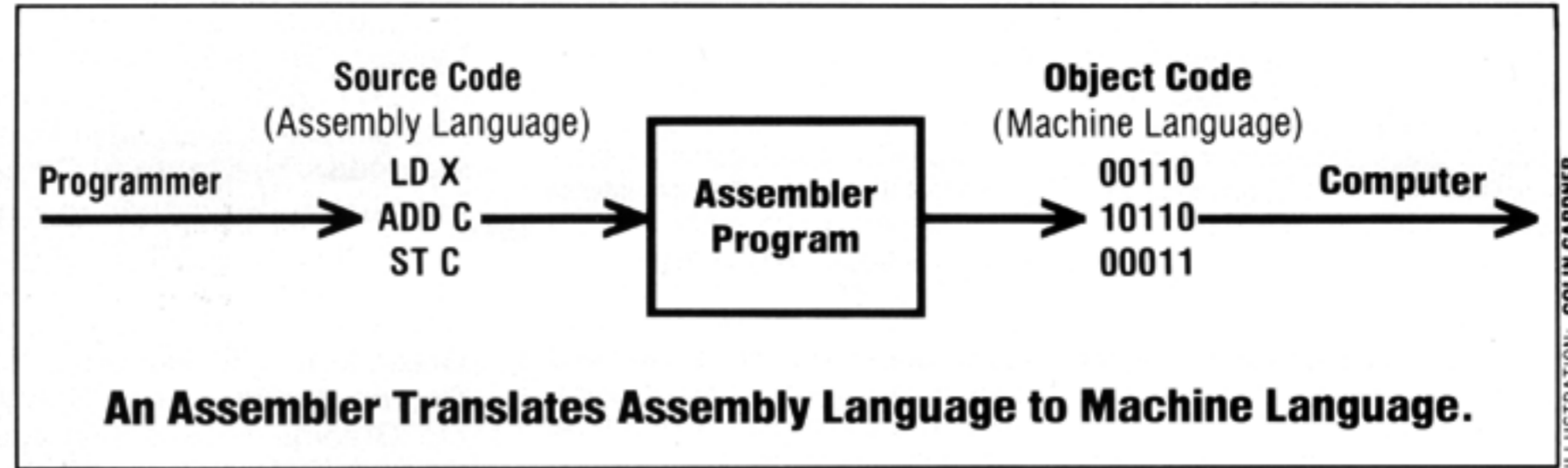

common definitions and conventions is referred to as a language. A computer language is very similar to the languages that humans communicate with.

It consists of a body of words and symbols, and rules for combining them, which impart meaning. Computer languages however, are much less flexible and have a smaller set of words and rules.

Now comes the question, how does a computer understand a language? There is a program which translates the incoming language to the sequence of instructions the computer understands. There are several types of languages. Some are very "high level" and look like English. Others are very basic and look like binary.

The most basic of languages is called machine language. In this language, the programmer controls the most minute detail in the computer. This language is written as a string of ones and zeros, and is usually entered via switches on the front panel. To add two numbers in memory using machine language would require a multiple step program to retrieve the numbers, add them, and replace them in memory. The programmer must know the address of each location. Needless to say, programming in machine language is very slow and error prone.

A welcome step from machine language is assembly language. This language still offers detailed

control over each of the computer functions, but also allows the programmer to use English abbreviations for the ones and zeros of machine language. Also, some memory management and addressing is done automatically. Since the computer really only understands the ones and zeros of machine language, the English abbreviations must be converted into binary. A program which does this translation is called an assembler. The assembler, which has been written in machine code, takes the programmer's program in English and converts it to binary for the computer. The programmer's program is called a source program, or source code. The source code is processed by the assembler which outputs object code—the machine language which the computer understands.

Even with the convenience of an assembler, the task of writing a program in assembly language is very error prone. Even worse, the programmer is liable to become a victim of the "forest for the trees" syndrome; that is, he can get so involved with the manipulation of the working of the machine, that he loses sight of his original task.

The solution to this problem lies in the development of task-oriented higher level languages. These languages are tailored to do specific types of problems, and have been written to do them clearly and efficiently. What is meant by a higher level language is that no longer is

there the one-to-one correspondence between a machine language statement and a higher level language statement. Higher level language statements can implement several assembly or machine language statements. "Hardware" functions are taken care of, such as memory allocation and timing. The symbols and syntax in these languages are more similar to English than to binary.

Popular high level languages for scientific purposes are FORTRAN, BASIC and PL-1. There is also a specialized business language called COBOL. In future issues, we will discuss two music languages, MUSIC and SCORE. All of these languages are machine independent, meaning that the object code can be run on different types of computers and still produce the same result.

It goes without saying that there must be a translation from these languages to machine language. The program which can do this is called a compiler. A compiler acts just like an assembler in that it translates one type of code to another. The output of the compiler can be either machine language, which can be run immediately, or assembly language, which would require it to be used with the assembler before it could be understood by the computer.

To review: The only language a computer understands is machine language, which is a string of ones and zeros. Because machine language is so difficult to use, other languages have been developed. These languages require a translator called an assembler in the case of assembly language; and a compiler in the case of other languages. These translators convert the English-like source code written by the programmer into binary object code, which the computer understands. The program must be translated before it can be run.

—Peter Hillen

A
D
I
N
D
E
X

All Ears Records	23	Micor	16
ARP	Back Cover	Moog/Norlin	11, Inside Back Cover
Audio Amateur	35	Ohio Electronic Music Centers	30
Blacet Musical Research	34	PAIA Electronics, Inc.	18
Boston School of Electronic Music	35	Peterson Synthesizer Rentals and Repairs ..	22
California Switch & Signal	30	Polyphony Magazine	22
CFR Associates	30	RolandCorp US	12
Craig Anderton Music Tape	34	Sam Ash Music	35
EML	30	Sequential Circuits	Inside Front Cover
EMS	35	Serge Modular Music Systems	9
Ken Schaffer Group	23	Sound Arts	34
Korg/Unicord Inc.	5, 13, 21	Yamaha International Corp.	7

LISTINGS

Synthesizer Manufacturers

Advanced Tools for the Arts, P.O. Box 825, Tempe, Ariz. 85281 □ **Aries Music Inc.**, P.O. Box 3065, Salem, Mass. 01970 □ **ARP Instruments, Inc.**, 45 Hartwell Ave., Lexington, Mass. 02173 □ **Audio Arts, Inc.**, 5615 Melrose Ave., Hollywood, Cal. 90038 □ **Blacet Music Research**, 18405 Old Monte Rio Rd., Guerneville, CA 95446 □ **CFR Associates ***, Box F, Newton, N.H. 03858 □ **Computone Inc./Lyri-con**, P.O. Box 433, Norwell, Mass. 02061 □ **Concert Company * ***, 3318 Platt Avenue, Lynwood, Calif. 90262 □ **Dataton AB**, Box 257, 2-581 02 Linkoping, Sweden □ **DBL Electronics**, 83 Morgan Circle, Amherst, Mass. 01002 □ **Dennis (Electronic Music Components)** 2130 Metcalf, Honolulu, Hawaii 96822 □ **Electrax**, P.O. Box 149, Tarzana, California 91356 □ **Electron Farm/Harvest**, Gregory Kramer, 135 W. Broadway, New York, N.Y. 10013 □ **Electronic Music Laboratories**, P.O. Box H, Vernon, Conn. 06066 □ **Electronic Music Studios**, The Priory, Great Milton, Oxford, England □ **E-mu Systems**, 3046 Scott Blvd., Santa Clara, Calif. 95050 □ **Farfisa**, 1330 Mark St., Elk Grove Village, Ill. 60007 □ **Galaxy Systems**, P.O. Box 2475, Woodland Hills, Cal. 91364 □ **Gentle Electric**, 140 Oxford Way, Santa Cruz, Cal. 95060 □ **HEAR**, 1122 University Ave., Berkeley, CA 94702 □ **Heuristics, Inc.**, 900 N. San Antonio Rd., Los Altos, Cal. 94022 □ **Inner Space Electronics**, Box 308, Berkeley, Cal. 94701* □ **Ionic Industries**, 128 James St., Morristown, NJ 07960 □ **Korg/Uncord**, 75 Frost Street, Westbury, N.Y. 11590 □ **Logistics**, Box 9970, Marina Del Rey, Cal. 90291 □ **MCI, Inc.**, 7400 Imperial Dr., Box 8053, Waco, TX 76710 (817) 772-4450 □ **Mediamix**, Box 484, Verdugo City, Cal. 91406 □ **Micom**, P.O. Box 20885, Phoenix, AZ 85036 (602) 273-4111 □ **MM Electronics**, **French's Mill**, French's Rd., Cambridge, England CB4 3NP □ **Moog/Norlin**, 7373 North Cicero Ave., Lincolnwood, Ill. 60646, Customer Service: 2500 Walden Ave., Buffalo, N.Y. 14225 □ **Music Computer**, P.O. Box 1070, Canyon Country, CA 91351 □ **Music Technology/Crumar**, 105 Fifth Ave., Garden City Park, N.Y. 11040 □ **Musitronics Corporation**, Sound Lab 10, Rosemont, N.J. 08556 □ **New England Digital Corp.**, P.O. Box 305, Norwich, Vermont 05055 □ **Oberheim Electronics**, 1549 Ninth St., Santa Monica, Calif. 90401 □ **Octave Electronics**, 32-73 Steinway St., Long Island City, N.Y. 11103 □ **PAIA ***, Box 14359, Oklahoma City, Okla. 73114 □ **Pollard Industries, Inc.**, 9014 Lindblade St., Culver City, Cal. 90230 □ **Polyfusion Inc.**, 160 Sugg Road, Buffalo, N.Y. 14225 □ **PPQ Ing. W. Palm**, Landwehr 11, D-2000 Hamburg, West Germany □ **Rocky Mount Instruments, Inc.**, Macungie, Penn. 18062 □ **Roland Corp U.S.**, 2401 Saybrook, L.A., Cal. 90040 □ **Saputelli Music Systems**, P.O. Box 40267, San Francisco, Cal. 94140 □ **Scala-tron/Motorola**, 2130 N. Palmer Dr., Schaumburn, Ill. 60196 □ **Sequential Circuits**, 1172-G Aster Ave., Sunnyvale, Cal. 94086 □ **Serge Modular Music**, 1107-1/2 N. Western Ave., Hollywood, Calif. 90029 □ **Software Technology Corp.**, P.O. Box 5260, San Mateo, Cal. 94402 □ **Solid State Music**, 2102A Walsh Ave., Santa Clara, Cal. 95050** □ **Star Instruments Inc.**, Box 71, Stafford Springs, Conn. 06076 □ **Steiner-Parker**, 2258 South, 2700 West, Salt Lake City, Utah 84119 □ **Stramp**, 3-2000 Hamburg 53, Bornheide 19, Germany □ **Strider Systems**, P.O. Box 2934, Norman, Okla. 73070 □ **Syn-Cordian**, 32:73 Steinway St., Long Island City, N.Y. 11103 □ **THING-Technical Hardware Inc.**, P.O. Box 3609, Fullerton, Calif. 92634 □ **VAKO, Synthesizers Inc.**, 4651 62nd Avenue North, Saint Petersburg, Florida 33565

□ **Wavemakers**, P.O. Box 27, Edmonds, Wash. 98020 □ **Yamaha International**, Box 6600, Buena Park, Calif. 90620 □ **360 Systems**, (213) 342-3127, 18730 Ox-nard Street, No. 215, Tarzana, Calif. 91356
Note: * manufacturer makes kits only
**manufacturer makes both kits and finished product

Consultants

Analog Systems, P.O. Box 1559, Boulder, Colo 80306 (303)499-4236 □ **Audio Designs**, 3422 Brookfield Ln., Decatur, Georgia 30032 (404) 284-8651 □ **Belgel Sound Lab**, 24 Main Street, Warwick, N.Y. 10990 □ **Michael J. Boddicker**, (213) 985-0010 □ **Boston Experimental Electronic Music Projects**, Robert Ceely, 33 Elm St., Brookline, Mass. 02147, (617) 731-3785 □ **Cincinnati Independent Electronic Studio**, David McClanahan, 2703 Coy St., Cincinnati, OH 45219 (513) 421-9025 □ **Clark Ferguson**, 83 Cherry Lane, Macungie, PA 18062 □ **Clean Music Systems**, 131 S.E. Fifth St., Hallandale, Fla. 33009, (305) 454-4601 □ **Danbury Electronic Music Center**, 84 Federal Rd., Danbury, Conn. 06810 (203) 792-2794 □ **Different Fur Music**, John Vieira, 3470 19th St., San Francisco, Calif. 94110, (415) 863-WAVE □ **Disco Tech Musical Electronics**, Prospect Mall, 2239 North Prospect, Milwaukee, Wisconsin 53202 (414) 271-9291 □ **Dorje Sound**, Chet Wood, P.O. Box 2232, Berkeley, Calif. 94702 □ **DS Music**, 811 Franklin St., Santa Monica, Calif. 90403, (213) 463-8772 □ **Electronic Music Consulting**, Michael W. Gilbert, 104 Riverglade, Amherst, Ma. 01002 (413) 253-2786 □ **Electronic Music Studio**, Dwight D. Gatwood, Director, University of Tenn., Martin, Tenn. 38238 (901) 584-7402, 578-2281 □ **Electronic Music Users Studio**, 37 Sussex St., San Francisco, CA 94131 □ **The Elektrik Keyboard, Ltd.**, 1920 North Lincoln Avenue, Chicago, IL 60614 (312) 751-1555 □ **EMSA (Electronic Music Studios of America, Inc.)**, 269 Locust St., Northampton, Mass. 01060 (413) 586-3777 □ **Exploratory Electronic Music**, Steven C. Bilow, 16685 Calneva Drive, Encino, California 91436 (213) 789-6885 □ **Lee Hargrove**, 155 Sanders Ferry Rd., Hendersonville, TN 37075 □ **Gygax**, 6117 Vineland Ave., North Hollywood, Cal. 91606 (213) 762-5962 □ **Keyboard Services**, P.O. Box 975, Baton Rouge, La. 70821 (504) 924-3858 □ **Laine Research & Development**, P.O. Box 3219, Fullerton, Cal. 92634 (714) 871-1923 □ **Lectron Music Lab**, Box 1594, Hollywood, Calif. 90028 □ **Stan Levine**, 13508 Debell St., Pacoima, Calif. 91331 (213) 899-7223 □ **Douglas M. Masia**, 551 Wilmot Rd., New Rochelle, N.Y. 10804 □ **The Mobile Synthesist**, Scott Clark, 1945 Trinity Ave., Suite No. 8, Walnut Creek, Cal. 94596 □ **Musicians Service Center**, 11321 Santa Monica Bl., West Los Angeles, CA 90025 (213) 473-6726 □ **Paradox EMS, Inc.**, 116 West Broadway, Vancouver, B.C., Canada V5Y 1P3 □ **Patchwork Sound**, Jack Howe, 14759 Hesby St., Sherman Oaks, Calif. 91403 □ **People's Computer Company**, P.O. Box 310, Menlo Park, Calif. 94025 □ **PI Corporation**, 1741 East 24th St., Cleveland, Ohio 44114 (216) 781-2207 □ **Rivera Music Services**, Ron Rivera, 48 Brighton Ave., Boston, MA 02134 □ **Schaeffer Enterprises**, 353 S. Sheridan Bl., Denver, CO 80226 □ **John Snyder, Experimental Music Studio**, 315 Kear St., Yorktown Heights, N.Y. 10598 (914) 962-5299 □ **Sound Arts**, 2825 Hyans St., Los Angeles, Calif. 90026 (213) 487-5148 □ **Dr. Phillip Springer**, Box 1174, Pacific Palisades, Calif. 90272 (213) 454-5275 □ **Star Track Recording Studio**, 8615 Santa Monica Blvd., Los Angeles, Calif. 90069, (213) 855-1171 □ **Carter Thomas**, Manpel Road, Spring Glen, N.Y. 12483 (914) 647-9121 □ **TNY Music & Engineering**, Route 4, Defreestville, N.Y. 12144 (518) 283-2837, 283-2899

Schools

BEEP Electronic Music Work-shops, 33 Elm Street, Brookline, Ma. 02146 (617) 721-3785 □ **Boston School of Electronic Music**, 127 Kilsyth Rd., Brighton, Mass. 02135 (617) 734-4500/4501 □ **Con Tempo Music Guild**, 13273 Ventura Blvd., Studio City, California 91604 (213) 784-8271 □ **James D. Craig Music**, 511 Cedar St., Allentown, Penn. 18102 (215) 437-4743 □ **Dick Grove Music Workshops**, 12754 Ventura Blvd., Ste. 2, Studio City, Calif. 91604 □ **Hawaii Electronic Music Group**, Box H-8 Room 213, 2445 Campus Rd., Honolulu, HI 96822 (808) 955-2839 □ **Omega Intermedia Center**, 3433 North Halsted, Chicago, Ill. 60657 (312) 477-9863 □ **PASS Public Access Synthesizer Studio**, 135 W. Broadway, New York, N.Y. 10013 □ **Sherwood Oaks Experimental Col-lege**, 6353 Hollywood Blvd., Hollywood, Calif. 90028 (213) 462-0669 □ **Soundbox Composition Studio**, 822 W. Hickory, Denton, TX 76201 □ **The Synthesists Workshop**, 551 Wilmot Rd., New Rochelle, N.Y. 10804

Sound Products & Accessories

Alembo, P.O. Box 759, Sebastopol, Calif. 95472 (707) 823-8579 □ **Analog/Digital Associates**, 2316 Fourth St., Berkeley, Cal. 94710 □ **Asgard Inc.**, 22 Huron St., Providence, RI 02908 □ **Audio Pulse**, 4323 Arden Dr., El Monte, Cal. 91731 □ **Audio Rents**, 6656 Sunset Bl., Hollywood, CA 90028 (213) 461-3351 □ **Barcus-Berry**, 15461 Springdale St., Huntington Beach, Cal. 92649 □ **California Optoelectronic In-dustries**, 999 Commercial St., Palo Alto, CA 94303 □ **Carvin Music and Sound**, 1155 Industrial Ave., Escondido, Calif. 92025 □ **E Bow/Heat Sound Products**, 611 Ducommun St., Los Angeles, Calif. 90012 (213) 687-9946 □ **Electro-Harmonix**, 27 West 23rd St., N.Y., N.Y. 10010 □ **Electro-Voice**, 674 Cecil St., Buchanan, Mich. 49107 □ **Eventide Clockworks, Inc.**, 265 West 54th St., New York, N.Y. 10019 (212) 581-9290 □ **FRAP**, Box 40097, San Francisco, Calif. 94140 (415) 824-2223 □ **FROGG (Design Engineering Labs Inc.)**, 4121 Redwood Ave., Los Angeles, Calif. 90066 (213) 823-8220 □ **Hammond**, 4200 Diversey, Chicago, Ill. 60639 □ **Heil Sound Systems**, Heil Industrial Blvd., Marissa, Ill. 62257 □ **HM Electronics**, 6151 Fairmount Ave., San Diego, Cal. 92120 □ **Ibanez/Eiger Co., P.O. Box 469**, Corn-walles Heights, PA 19020 □ **Inflithreatre Inc.**, 4990 Mass Ave., Indianapolis, Ind. 46218 □ **J. D. Electronics, Inc.**, P.O. Box 2205, Berkeley, Cal. 94702 □ **Keas Electronics, Inc.**, 210 W. Main, Chanute, KS 66720 □ **Marshall Electronic**, Box 177, Joppa, MD. 21085 □ **Mellotron/Sound Sales Inc.**, Sherman Conn. 06784 □ **Mellotron/Sound Sales Inc.**, Sherman Conn. 06784 □ **Micmix Audio Products, Inc.**, 2995 Ladybird, Dallas, TX 75220 □ **Morley Electronics**, 2301 West Victory Blvd., Burbank, Calif. 91506 (213) 843-7122 □ **MR Engineering Co.**, 4730 W. Addison, Chicago, IL 60641 □ **Musico**, 1225 N. Meridian St., Indianapolis, Ind. 46204 □ **MXR Innovations**, P.O. Box 722, Rochester, N.Y. 14603 □ **Nasty Cordless**, P.O. Box 2205, Berkeley, CA 94702 □ **Pro Sound**, 13717 S. Normandie, Gardena, Cal. 90249 □ **Rocronics Entertainment Lighting**, 22 Wendell St., Cambridge, MA 02138 (617) 354-4444 □ **Rolls Electronic Corporation**, 4260 Lankershim Bl., North Hollywood, Cal. 91602 □ **Ross Musical Products/Keas Electronics Inc.**, 210 W. Main, Chanute, KS 66720 (316) 431-0400 □ **Rothchild**

20 words or less \$5.00, 40 words or less \$10.00, 60 words or less \$15.00. Send payment with ad to: Synapse Classifieds, 2829 Hyans St., L.A., CA 90026.

For Sale—Electronic music parts (Personal surplus). SASE brings current list. 1561 Kildare Way, Pinole, CA 94564.

For Sale: Original RCA Theremin owned by Dr. Samuel Hoffman. Illustrious film & recording history. Fine condition. Contact Gary, (213) 649-3935.

1 - 360 Systems Slave Driver with pick-up. For interface of guitar to synthesizer. Excellent condition. \$600. Robin Evans R.R. No. 1, Pemberville, OH (419) 352-2623.

Telequipment D-61a dual trace oscil-oscope, excellent shape; \$450.00. John Bement, RFD 2, South Royalton, Vermont 05068 (802) 763-8212.

Record Collectors Rare Japan, Europe and U.S. rock LPs. Write for free catalogue. Record Fun Club, Dept. T Box 3258, Missoula, MT 59801.

Musical Instruments (distributor Fur-man and Alembic products), 65 McCoppin St., San Francisco, Calif. 94103 (415) 626-2260 □ **The Ken Schaffer Group**, 10 East 49th St., New York, New York 10017 □ **Senn-heiser Electronic Corp.**, 10 West 37 St., New York, N.Y. 10018 □ **TAPCO**, 3810 148th Ave., NE, Redmond, WA 98052 (206) 883-3510 □ **Wasatch Music Sys-tems**, P.O. Box 9175, Salt Lake City, Utah 84109

Sound Recording

Ampex, 401 Broadway, Redwood City, Calif. 94063 (415) 367-4544 □ **dbx Incorporated**, 296 Newton St., Waltham, Mass. 02154 (617) 899-8090 □ **Dokorder**, 5430 Rosecrans Ave., Lawndale, Calif. 90260 □ **Dolby Laboratories Inc.**, 731 San-some St., San Francisco, Calif. 94111 (415) 392-0300 □ **EDCOR**, 3030 Red Hill Ave., Costa Mesa, Calif. 92626 (714) 556-2740 □ **Furman Sound**, 616 Canal Street, Suite 25, San Rafael, California 94901 (415) 456-6766 □ **Magnetic Reference Laboratory, Inc.**, 229 Polaris Avenue, Suite 4, Mountain View, Calif. 94043 (415) 965-8187 □ **Maxell Cor-poration of America**, 130 West Com-mercial Ave., Moonachie, New Jersey 07074 □ **Nagra Magnetic Recorders, Inc.**, 19 West 44th St., Room 715, New York, N.Y. 10036 □ **Orban/Parasound**, 680 Beach St., San Francisco, Calif. 94109 (415) 673-4544 □ **Otari Corporation**, 981 Industrial Road, San Carlos, California 94070 (415) 593-1648 □ **Philips Audio Video Systems Corp.**, 91 McKee Drive, Mahwah, N.J. 07430 □ **Pyramid Electronics Products**, PO Box 6171, San Rafael, Cal. 94903 □ **Scientific Audio Electronics Inc.**, P.O. Box 60271, Ter-minal Annex, Los Angeles, Calif. 90060 □ **Scotch/3M Magnetic Audio/Video Products Division**, 3M Center, Saint Paul, Minn. 55101 □ **Souly Recording Instruments**, 475 Ellis St., Mountain View, Calif. 94943 □ **Shure Brothers Inc.**, 222 Hartrey Avenue, Evanston, Ill. 60204 □ **TDK Electronics Corporation**, 755 Eastgate Blvd., Garden City, N.Y. 11530 □ **TEAC Corporation of America**, 7733 Telegraph Road, Montebello, Calif. 90640 □ **Telex Com-munications Inc.**, 9600 Aldrich Avenue South, Minneapolis, Minn. 55420 □ **United Recording Electronics In-dustries**, 8460 San Fernando Rd., Sun Valley, Cal. 91352 (213) 767-1000



• ARPAVATAR •

**"Genesis has a special sound,
and my Avatar blends in perfectly."**

Daryl Stuermer/GENESIS



Jazz-rock guitarist Daryl Mark Stuermer has performed and recorded with top artists like George Duke and Jean Luc Ponty.

Today he's touring with *Genesis*, one of rock's premiere groups, and he's playing the most revolutionary musical instrument of the decade: the ARP AVATAR guitar synthesizer.

"Using the Avatar is like having a second instrument available without changing instruments. I can play straight guitar and bring in the sound of the synthesizer just by picking harder. That's quite a powerful feeling for any musician, particularly a guitarist."

Daryl's hexaphonic pickup is mounted on a customized Hagstrom guitar with a Les Paul neck. On stage, he makes maximum use of the Avatar's multiple outputs by playing through three separate amps.

"I have the hex fuzz sound coming through a Mesa Boogie, and a warm synthy sound coming through the Sunn, plus my straight guitar sound coming out of another amplifier. It comes out really full."

The Avatar has added a new dimension to the sound of *Genesis*, as well as a new dimension to Daryl Stuermer's musical career. All the sound potential of the Avatar has expanded the range of musical expression under his control. And the challenge of mastering a new instrument — without giving up his favorite axe — has enhanced his development as a professional musician.

"Playing the Avatar has made me a better guitar player and a better musician. Going from jazz to rock was a big change for me, but going from straight electric guitar to guitar synthesizer was an even bigger change. I'm thinking in terms of bass parts, melody, mixing the synthesizer with the qualities of the guitar, now that I have the Avatar. I have to say it's made a difference in my career and my music . . . like I've broken into a whole new field."

Like hundreds of leading professionals, Daryl Stuermer is breaking new ground and creating new sound with the Avatar. Ask for a demonstration where you see this sign,



or send \$1.00 for a brochure and musical demonstration.

ARPAVATAR

It's the sound.

Send \$1.00 for more information to: Dept. A
ARP Instruments, Inc., 45 Hartwell Avenue, Lexington, Massachusetts 02173

Listen for these fine artists playing the ARP AVATAR:

Pete Townshend/The Who • Jeff Lynne/Electric Light Orchestra • Roy Buchanan • Lou Reed • Bo Diddley • Jimmy Page/Led Zeppelin
• Pat Metheny • Kerry Livgren/Kansas • Orville Saunders/The Blackbyrds • Walter Becker/Steely Dan • Carlos Santana/Santana • Ace Frehley/Kiss
Dominic Troiano • Howard Leese/Heart • Steve Fossen/Heart • Roger Fisher/Heart