

International electronic music

January/February 1978
Volume 2, Number 4
USA & Canada \$1.50
Australia,
Europe & Japan \$2.00

Synapse

**Jan
Hammer**



**Karlheinz Stockhausen - Part 2
Timo Laine , Guitar Synthesist
Production in the Home Studio**

Hooke

Holley

ARGYRE

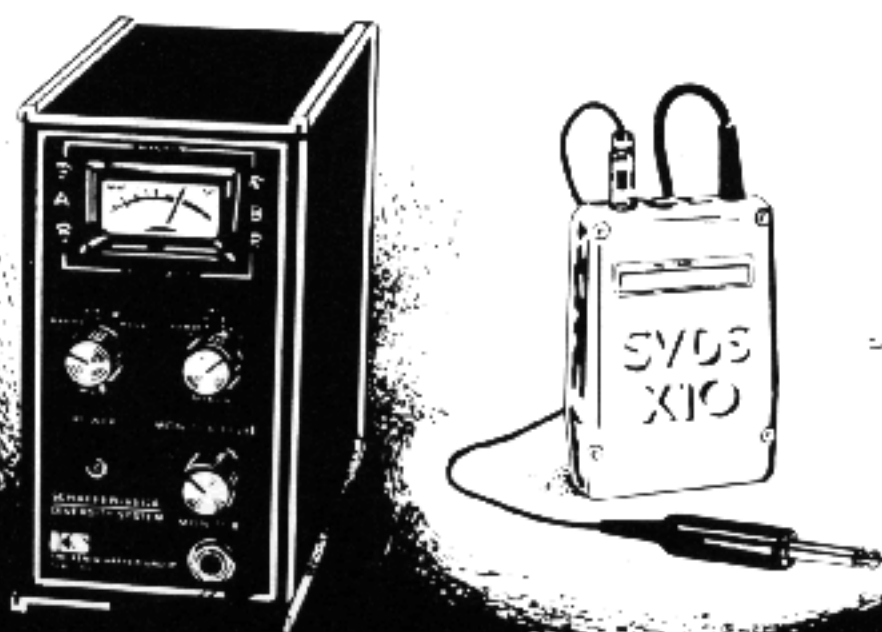

NO STRINGS ATTACHED!

It's the greatest advance in electric instruments since Les Paul... there's now no need for a cord between your instrument and its amp.

Schaffer-Vega Diversity Systems, for all instruments and hand-held mics guarantee a minimum 100 yard performing range, give complete protection against electric shock, and — — — it's no gimmick — — — make no compromise in your sound.

Since June, over 50 major bands have gone wireless, and every one of them has done it with SVDS — — — **EVERY ONE** of them.

We're already standard performing equipment for Stephen Stills, Kiss, Steve Miller, Ted Nugent, Foreigner, Peter Frampton, Heart, Derringer, AC/DC, America, Commodores, Nektar, Mahogany Rush, E.L.O., Peter Gabriel, Fifth Dimension, Earth Wind & Fire, The Beachboys, and Thin Lizzy.

Get rid of the limitations of cords for once and for all... you can enter the house from behind, playing all the way, and never get shocked again.

Call... or send \$1 for complete specs.

SVDS instrument systems \$3300.
Operating Manual \$5

WE BEAT TIME & SPACE

The instantly famous Schaffer-Vega Diversity System gives you control of space---and lots of new performing possibilities.

Less than half a mile from the womb that spawned SVDS is the nest of Eventide: the world's foremost manufacturer of exotic time domain modifiers. So we're also the one stop you can make to master time.

The Ken Schaffer Group is one of the world's major suppliers of top-of-the-line special effects equipment. Particularly, **Eventide Digital Delay (1745M)**, the **Eventide Harmonizer™**, **Instant Flanger™** and **Amazing Omnipressor™**. We've supplied hundreds of major bands and studios.

Normally kept on stock for immediate delivery. We also offer a number of exclusive custom modifications which make the entire Eventide line even more versatile in both live and studio application.

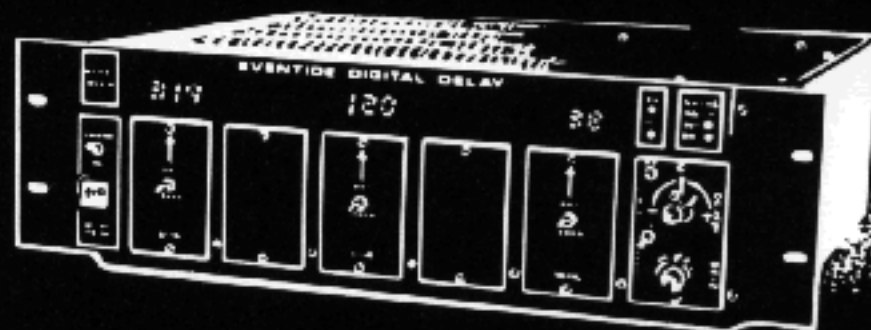

Eventide is the standard delay equipment for nearly every major studio on six continents. It's the secret behind dozens of special effects you hear in live concert with nearly every major band. It's far and away the best.

(List Prices: Model 1745M \$4100; Pitch Change Module \$850; Additional Plug-in independent delay outputs \$550; Harmonizer, all options, \$1865; Polyphonic Harmonizer Keyboard \$600; Instant Flanger \$615; Omnipressor \$600).

Complete Operating Manuals @ \$5 each.

Time and Space.



THE KEN SCHAFFER GROUP, INC.

10 East 49th Street • New York, New York 10017 • (212) 371-2335

Synapse

Editor
Douglas Lynner

Art Director
Chris August

Photography
Bill Matthias

Contributing Editor
Colin Gardner

Contributing Writers
Craig Anderton, John Blacet,
Alex Cima, Janet Henshaw Danielson,
Bob Davis, Peter Hillen, Mark Linden,
Barton McLean, Steve Roach,
Danny Sofer, Carter Thomas,
Eric Valinsky.

Correspondents
Boston: Kenneth Perrin
Northern California: Phil Loarie
Connecticut: Chuck Scribner
Maryland: Paul Medlock
Minneapolis: John Borowicz
Oklahoma: Richard Bugg
San Diego: Steve Roach
Texas: Barton McLean
England: K.S. Dulay
Japan: Eiji Ueda
Sweden: Gregory Allen Fitzpatrick.

Contributing Artists
John Blacet, Sue Denim, Jackie Milan.

Photographers
Brian Cooke, Chris Dierdorff,
Guido Harari, Eve Kessler,
Robert Landau, Mark Linden,
Bill Matthias, Bernard Perrine,
Virginia Quesada, John Scheele,
Jon Sievert, Charles Smith.

Production
Colin Gardner, Bill Matthias

Cover Photograph
Bill Matthias

Synapse is published bi-monthly at 2829 Hyans Street, Los Angeles, CA 90026 by Synapse Publishing Co. The entire contents of Synapse are copyright © 1978 Synapse Publishing Co., all rights reserved, and may not be reproduced in any manner, either in whole or in part, without the written permission of the publisher. Application to mail at second-class postage rates is pending at Los Angeles. Manuscripts, photographs & artwork: All contributions are welcome, however, we cannot be responsible for the return of unsolicited materials. Enclose a self-addressed stamped envelope with any contributions and send to Synapse, 2829 Hyans Street, Los Angeles, CA 90026. Advertising Contact Doug Lynner or Chris August at (213) 383-7933 for our current rate and deadline schedule. Distributors & Dealers: Contact Chris August or Doug Lynner at (213) 383-7933 for discount information and publishing schedule. Subscriptions: Within the US the annual six issue rate is \$8.00. A domestic first class mail subscription is available for \$14.00 yearly. The one year foreign subscription rate (by surface mail) is \$10.00. A special foreign air mail subscription is now available for \$20.00 annually. Single copy newsstand price is \$1.50 in the US and Canada; Australia, Europe, and Japan \$2.00. Back Issues: We are presently sold out of most issues. Please send a postcard for our files naming the issues you lack and they will be reprinted when demand is sufficient. Change of address: Notify Synapse/Subscriptions at 2829 Hyans Street, Los Angeles, California 90026. Please send both the old and new addresses, and if possible, the mailing label from your copy of Synapse.

Timo Laine

Guitar synthesist.

—Chris August and Doug Lynner—



24

Jan Hammer

Beyond jazz/rock.

—Doug Lynner—

28

Karlheinz Stockhausen

The search for control—Part Two

—Janet Henshaw Danielson—



32

David Rosenboom

Recent
cybernetic insights

—Bob Davis— 18

Production

Professionalism
in the home studio

—Craig Anderton— 20

Report

The International
Computer Music
Conference

—Eric Valinsky— 22

Realtime

Electronic Music

Expanding
realtime capability

—Eric Valinsky— 36

The Beat Goes On

—Part II

Combination Tones
and Temperament

—Jon Dattoro— 38

2:4 Notes from the publishers 2

Letters Reader feedback 2

What's Happening

Around the world 4

Performance International

Computer Music Conference, L.A.

Electronic Music Festival 12

Survival Notes Copyright

Law Changes 14

Discola Utopia, Steve Hillage,

Peter Baumann, Jan Hammer Group,

Donald Knaack, & New Releases 16

Construction Voltage

Controlled Clock with Event

Arranger 44

Guitar Synthesis Leon Gaer's

electric bass controlled synthesizer 46

Advertisers' Index 46

Equipment Eμ 4060 Series

Polyphonic Keyboard and Sequencer .. 50

Synthesis Ambience, Part I 52

Computers Sample and Hold-

A/D Conversion 54

Listings Addresses of interest 54

Classifieds Buy, sell, trade,

make, and have made 55

Thank You John

Nov./Dec. just arrived. Book looks good, interview looks good, ad looks good. But, what *really* is the most impressive is the letter and reply "Can't Please Them All." Beautiful.

Keep goin'
John Simonton
PAIA Electronics, Inc.
Oklahoma City, OK.

Correction Please

A correction to Danny Sofer's Synthesis column, March/April 1977: The triangle wave does *not* have all of the harmonics. It contains only the odd multiples, exactly as does the square wave. The difference between the two is that a triangle wave harmonics amplitude is only $1/n^2$ of the fundamental's amplitude, while the square wave harmonic is much louder, $1/n$. The letter "n" simply stands for the number of the harmonic, i.e., the multiple.

Sincerely,
Reynold Weidenaar
Cleveland, Ohio

Thank you for correcting my oversight. Ed.

How About. . .

Consider the benefits of producing recorded sound sheets or tapes as an integral part of your magazine (let the subscribers underwrite it). Such poignancy! Truly a unique "synaptic" new media process . . . literally interconnecting the medium with the message with the molecules, so to speak.

Tom Gibbs
Austin, Texas

User Orientation

I find your magazine makes all others who even remotely try to deal with synthesizers as trivial and flimsy at best. On the other hand Synapse does not seem to be linked into any particular machine construct. It deals with the conceptual building blocks of systems and configurations. I find this may prompt many people to start tearing at their mass-produced synthesizers to put in the necessary input/output functions for their own personally oriented machines (I feel this is good—one needs to feel at home in his/her own space). It will also stimulate the market to put out more user oriented machines. Anyway, I enjoy someone not cutting corners when describing functions (and possible functions). Keep it up.

Gilbert P. Kettles Jr.
Ithaca, N.Y.

Technical And Aesthetic

As an electrical engineering student at Tufts University, and an electronic music student at the New

England Conservatory, I am very pleased to discover that a magazine exists which is concerned with both the technical and artistic aspects of electronic music.

Although most people would probably associate electronic music with the clichéd use of synthesizers by many rock performers, it is gratifying to see (at least in the issue I bought) that your record reviewers devote some space to what must comparatively seem like obscure works of "that avant-garde stuff."

While I did find the interviews with the more popular artists interesting (specifically, Vol. 2, #1), and definitely worthwhile, I

think that some form of articles about the aforementioned would indeed be vital to at least remind people of the more abstract origins and potential that the catch-all, presently strained term "electronic music" is today.

Very sincerely yours,
Robert J. DiCamillo
Medford, Ma.

Next issue will feature an interview with Jean Claude Risset, composer and director of IRCAM's Computer Department. Also featured will be synthesist Jean-Michele Jarre. I hope Synapse is living up to its name. Reader feedback is the best way to be sure. Thanks for yours. Ed.

2:4

Here is the first Synapse of 1978, a year we expect to be very important for electronic music. Twenty days into '78 will be the National Association of Music Merchants annual Western Market Convention. The convention, to be held for three days at Disneyland, will feature the product lines of most musical instrument and equipment manufacturers. NAMM can usually be counted on for some interesting product unveilings and Synapse will be there and won't miss a thing.

We expect to see much development in the interface of digital and analog electronics, as well as totally digital music systems. Another area of continued development will be that of alternative controllers for synthesizer. Activity in interfacing traditional instruments to synthesizers has already been considerable but the synthesizer still lacks a controller to call its own. An advance in that area alone could make this an unforgettable year.

Other areas that we hope will continue to develop are the standardization of jargon for electronic music in performing, composing and manufacturing; increased capabilities for interfacing all brands of synthesizers; and a notational vocabulary of electronic music, both on the level of patches and pieces.

Synapse will, of course, do its best to make 1978 a memorable year by continuing to expand its coverage of all aspects of electronic music and by presenting the material in an ever improving format. And don't hesitate to send suggestions as they are necessary and welcomed.

Before this year gets further on, we would like to thank our writers, artists, photographers, correspondents, advertisers, distributors, vendors, and especially our readers; all of whom, by their interest and support, have created an electronic music magazine, at last.

Chris August & Doug Lynner
Publishers,
January 1, 1978

personally would like to see occasional articles dealing with the major artistic and technical achievements by the pioneers of the 1950's and 1960's which many a time has caused the outgrowth and development of those systems which are so commonly used in the popular mainstream. If your publication's claim of being "the electronic music magazine" is to be consistently upheld, then I would

Back Issues

You state that if you get enough requests that you will possibly reprint your sold-out issues. Well, besides myself I can think of at least ten other friends who would love to be able to own a copy of these issues. Please do reprint them. I must commend you on your excellent publication and I am incredibly pleased that there is a magazine of such high caliber in

the field of electronic music. The only problem is, no newsstands carry your magazine! So, I subscribed and just got my first issue, Vol. 2, #2 and am very pleased. Keep up the good work. I look forward to many more fine

issues in the future. How about an article on Brian Eno or a "coming soon" column on future issues. Just a few ideas I can think of. Well, thank you for your contribution to the enhancement of my electronic music knowledge and I will definitely turn more people on to your fine publication. One other thing. How about a mailing envelope for subscribers? I like to keep my magazines in good shape and the mail destroys the covers all the time.

Thanks very much
Andrew Schlesinger
Ithaca, N.Y.

This issue's subscription ad offers a new, first class postage (mailing envelope included) subscription that may interest you and other Synapse readers. A similar subscription is being offered for foreign readers.

Synapse can be found on newsstands in many areas of the country and we are working hard to find distributors and outlets in the remaining areas. If Synapse is not sold where you buy magazines, tell them you would like to purchase Synapse there and give them our address if you can. A newsstand dealer carries what his customers want to read, so let them know what you want. Ed.

Small World

Call it coincidence or whatever, that there is now a magazine of electronic music entitled Synapse. You may be interested to know that the Synapse New Music Chamber Ensemble has been performing concerts of new music in western Canada since March, 1974.

Thank you very much for your consideration. I remain

Yours sincerely,
J.A. Ozipko
Edmonton, Alberta

Thanks for your letter. It's a pleasure to be in such good company. Ed.

Valuable Information

I have recently purchased the E-mu Systems 4060 Synthesizer with three voices as a starter. I also have an ARP 2600 which I've interfaced to the E-mu. I have read a few issues of your magazine and think it's a most welcome source of valuable information. Good luck to you all and keep up the good work.

Burt Alcantara
New York, N.Y.

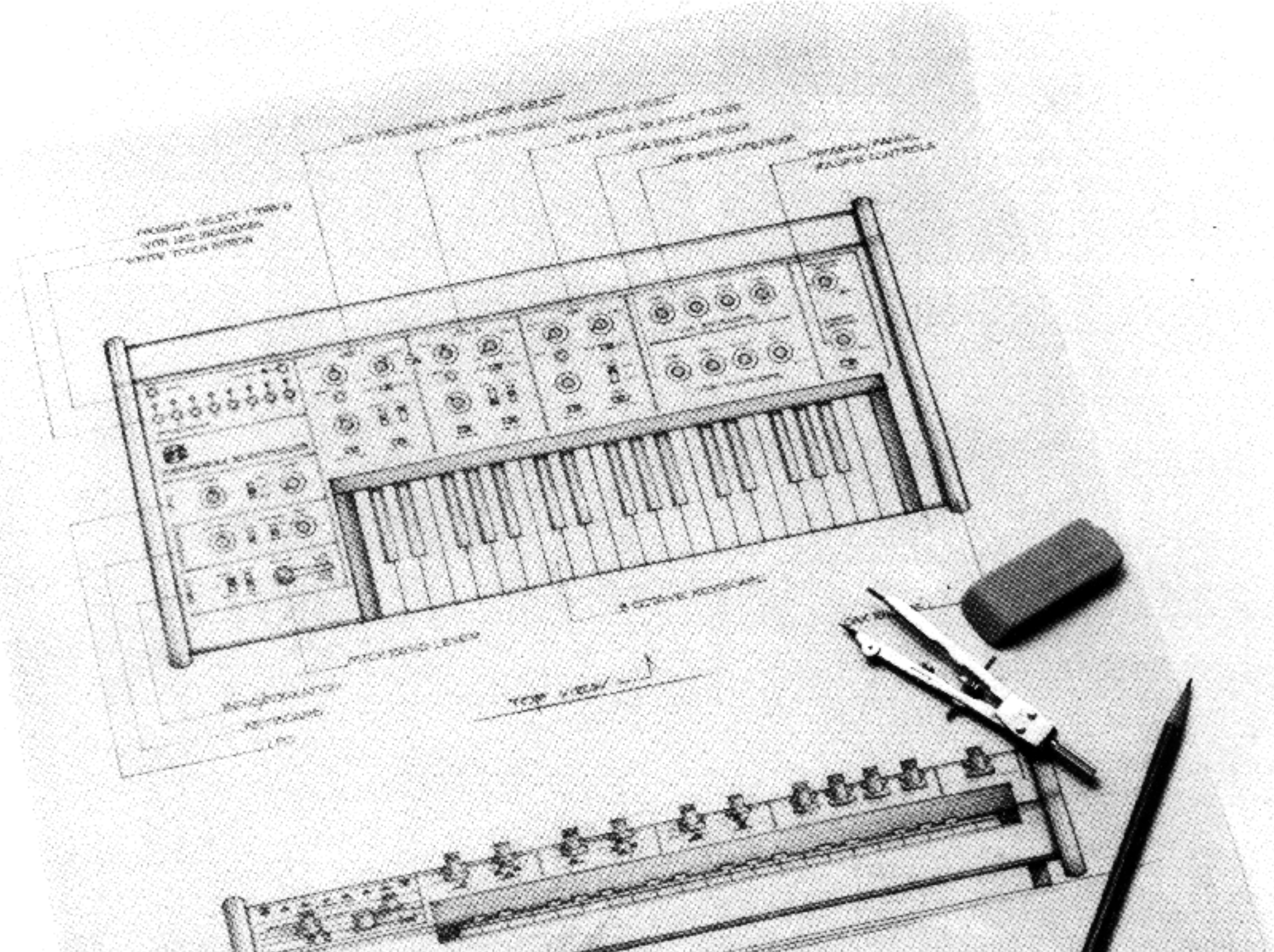

OBERHEIM PROGRAMMER TECHNOLOGY IN A LEAD SYNTHESIZER.

Oberheim Electronics has been manufacturing Polyphonic Synthesizers for the professional music market for two years. During that period Oberheim Synthesizers have managed to find their way to the finest keyboardists around. Who, in turn have created some of the best music recently released. Consequently Oberheim has become one of the most respected electronic music companies in the world. At times it seems by accident, luck or chance that it all happened so quickly. However, when examined more closely reality emerges. Oberheim addresses the professionals' needs for creative expression with roadable equipment at the forefront of technology.

This philosophy in product development is again exhibited in the introduction of the fully programmable lead synthesizer "The OB-1." The OB-1 combines the simplicity of a preset synthesizer with the versatility of a variable synthesizer yet you're not

locked into factory presets (which are probably some engineer's idea of what a particular sound should sound like). The OB-1 does come pre-patched from the factory for those who aren't into patching right away, so you can immediately use it while you learn the machine. Should you never get into tweaking and turning knobs, cassette tapes will be available (within a few months) along with a tape interface device which will allow you to re-program your machine with a variety of sounds.

On the other hand, being a totally variable synthesizer, those who wish to create their own sounds can! When you achieve the sound you want you can store it in the memory of the OB-1 by simply touching two buttons. The patch will remain there until you write over it with a new patch of your own design or one via the soon to be available cassette tapes from Oberheim.



Oberheim

Some Things Are Better Than Others
Oberheim Electronics, Inc., Dept O1
1549 9th St., Santa Monica, CA 90401

WHAT'S HAPPENING

... Synapse has extended the deadline for entering the Synapse/Viking Give Away to February 25, 1978. To win a free custom re-packaging of any two of your Keyboards (plus modifiers) in a heavy duty road and performance case, send postcards only to: Synapse/Viking Give Away, 2829 Hyans St., L.A., CA 90026. Enter as many times as you like but remember, entries received in subscription envelopes are automatically disqualified.

... Furman Sound (distributed by Rothchild Musical Instruments) has released the TX-2, a tunable crossover and band pass filter. The unit is promoted as being for P.A. and concert loud speaker systems, stu-

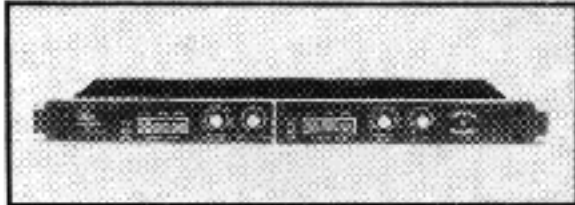

Furman Sound TX-2 tunable crossover and bandpass filter.

dio monitor systems and as a band pass filter. The system is tunable from 20 to 20,000 Hz. and can be used as a stereo bi-amp or a mono tri-amp. The manufacturer lists the retail price at \$250.00.

... Continuing in the tradition of alternatives to industry and academic settings for music production, Bay Area Synthesis Studios (BASS) have opened a multi-track studio with a large E-mu modular synthesizer. The studio, directed by Anthony Catania, will offer its facilities to composers as an aid to continue work after normal channels have been exhausted, or graduated from, as the case may be. For more information, please contact BASS, 37 Sussex, San Francisco, Cal. 94131.

... Synapse recommends Music Works (83 McAllister St., Room 403, San Francisco, Cal. 94102) for musicians that don't want to truck their music out in ignorance. This very attractive magazine discusses all aspects of the music biz (from the musician's point of view) including: management, contracts, concert promotion, concert production, recording, songwriting, and equipment. Although the magazine is directed to and draws upon the bay area community, the contents are of value to any contemporary musician. Drop them a line and include \$3.00 for the current issue.

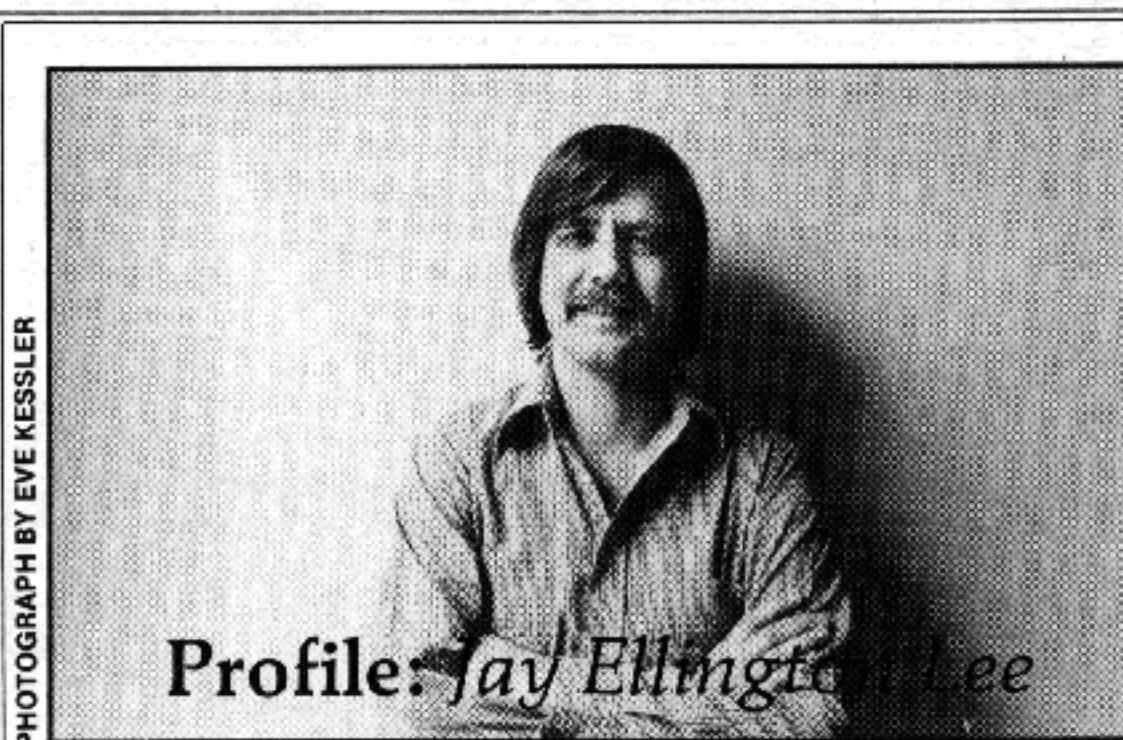

PHOTOGRAPH BY EVE KESSLER

Profile: Jay Ellington Lee

Educated at Cambridge University, and a former pupil of Karlheinz Stockhausen and Morton Subotnick, electronic music composer Jay Ellington Lee is currently based in lower Manhattan, where he divides his time between serious compositional work and more commercial music. The latter is particularly prominent in commercials, including assignments for Shimano Bicycles, IBM, Time-Life, Xerox and Pepsi Cola. Lee also composes film scores, many of which have won awards, and include the upcoming AVCO-Embassy release, Temple of Time.

Lee's non-commercial works include a soon to be released electronic music album. The disc will be the result of many years of evolving technique, closely connected with Lee's involvement in developing many design concepts for E-mu Modular Systems. Significantly, amongst Lee's equipment is a massive E-mu digitally controlled analog synthesizer. Its memory system can hold up to 512 words, which can be loaded by the keyboard and stored on cassette tape. If a composition takes more words than the memory can hold, the tape allows additional storage of thousands of words. As a result, one can store a complete composition on tape, which can then be fed into the memory at any time.

A device called a tape sync pulse counter, made by Ampersand Company, is used to make a click track for the precise length of the composition. The click track is used to gate the memory or the transient generators in order to advance the memory. The multi-track tape machine is modified to accept a digital signal so that a pulse can turn the recorder automatically into record mode. When the memory runs out, a pulse stops the recorder and a new section of memory is loaded. The process can be repeated as many times as required, and using this method all parts of the composition are kept in proper sync. The Ampersand tape sync pulse counter can also provide a divide pulse so that one can create polyrhythms and complex rhythm patterns.

The result of this highly refined technique is a particularly original music of rich timbral quality and delicately executed orchestration. Lee feels that the particular hardware used in each piece is dictated by the music, and he buys or builds new devices to fully realize his ideas. To facilitate more advanced production, in the near future Lee plans to have a full 16 track studio, especially set up for electronic music and open for use by other composers and musicians at low hourly cost. Lee feels that the studio will help people who don't have complete access to equipment to create higher quality material.

Lee also plans to perform live in the near future. This will involve modifying the E-mu so that it has the ability to read and write simultaneously, allowing Lee to perform his works in real time in a concert situation, his preferred medium. With the ability to perform live, Lee also hopes to do workshops for adults and children alike, hopefully widening the acceptance of real time electronic music through educational example.

Carter Thomas

... As are most areas of the country, San Francisco is bristling with small recording studio activity but with a twist. More and more studios promote synthesizers as their specialty. I suppose it's no surprise, since you will find a lot of familiar faces in the synthesizer studio after visiting the recording studio of the same university or college. For the record, for 8-tracks, contact: Short Circuit Productions, (415) 864-9357.

... New and of interest from Analog/Digital Associates is the Final Phase phase shifter. As is their tradition, control voltages are accepted by the system allowing considerable advantage over normal foot pedals. New to the design (when comparing



Final Phase by Analog Digital Associates.

to the Flanger) is a foot switch to change from voltage control to automatic or system control; a small but meaningful advance. Retail price of the Final Phase alone is \$139.95

... For those readers with a special interest in European "new music", send for a copy of the Feedback Papers (Feedback Studio Verlag Köln, Center Strasse 23, West Germany). The works and thoughts of many contemporary musicians (not all German) are explored from an unusual standpoint, making the result all the more interesting.

... A.R.C. Publications has recently released Desert Plants: Conversations with Twenty-Three American Musicians, by Walter Zimmerman. The book, as the sub-title explains, includes conversations with many important if not influential American composers. The information is well overdue, to be sure, and a look through the book will acquaint you with who is who in one area of contemporary American music. Send \$9.50 to: A.R.C. Publications, Aesthetic Research Centre of Canada, P.O. Box 3044, Vancouver, B.C. V6B 3X5. Thank you Canada

Continued on page 7

FINALLY.



You're a keyboard player, and a good one. That's why you deserve a synthesizer that gives you control. One that responds to your hands, and the technique you've perfected. An instrument that allows and encourages creativity, and lets you play *music*. In short, the all-new Yamaha CS-80 Polyphonic Synthesizer.

The CS-80 is velocity sensitive and pressure sensitive. The volume and brightness, as well as the character of the sound is in your hands.

You have control not only over the notes you play, but also the 22 internal preprogrammed voices, including Strings, Brass, Clavichord, Organ, Electric Piano, Electric Bass and Guitar. The voicings and settings are

A SYNTHESIZER THAT PLAYS AS GOOD AS YOU DO.

easy. But your creativity is never compromised: adjust envelope characteristics, filters and equalization, vibrato, pitch and touch response so that you get your taste, not somebody else's.



 **YAMAHA**

P.O. Box 6600, Buena Park, CA 90622

Four memory banks let you summon the voices *you've* created and preprogrammed.

Because the CS-80 is a polyphonic synthesizer, eight notes can be played simultaneously, generated by 16 oscillators. And with two channels you get the added flexibility of producing two different voices in any mix you want.

You'd expect a one-of-a-kind synthesizer to come from the people who've been perfecting musical instruments for nearly a century. Write for a free brochure. Or try a first: play *music* on a polyphonic synthesizer. The CS-80. Or try the CS-60, or the CS-50. They're all polyphonic, and they're all at your Yamaha dealer.



"I'm happy there is an electronic music magazine. I'm especially happy with the diversity of subjects being presented." Tom Oberhelm of Oberheim Electronics.

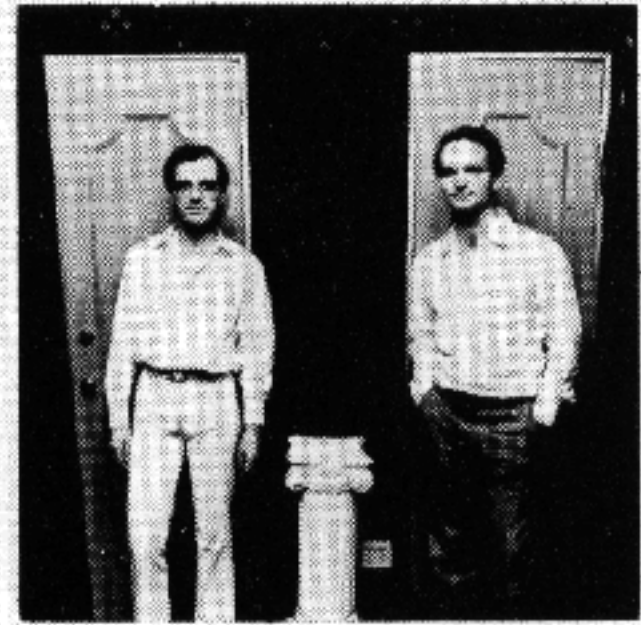

"We like your magazine. There is no magazine comparable in Europe!" Ralf Hutter and Florian Schneider of Kraftwerk.

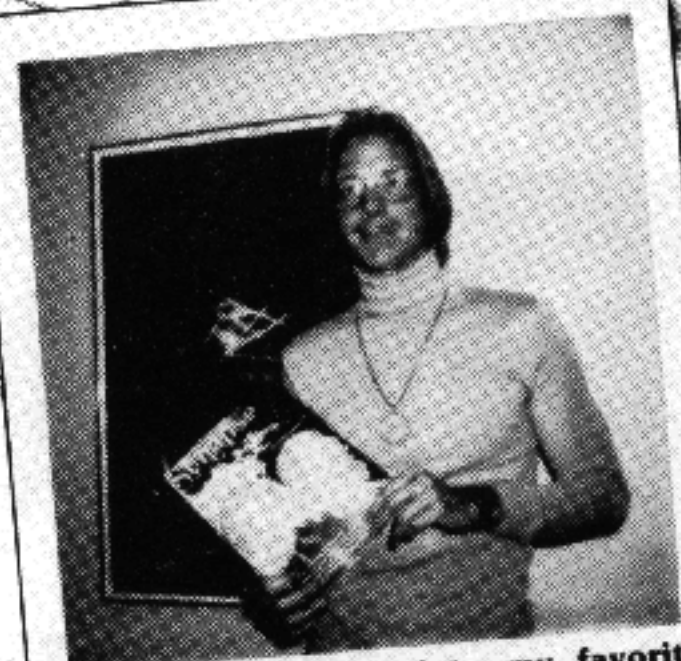

"Synapse plugs me into my favorite music. It's my electronic connection and I need it regularly." Ivan Dryer, President Laser Images, Inc. and Creator of LASERIUM.



"An absolute necessity . . . your reviews are very important in our synthesizer work." Bob Benkelman and Ronny Schiff of ALMO Publications, an affiliate of A&M Records.

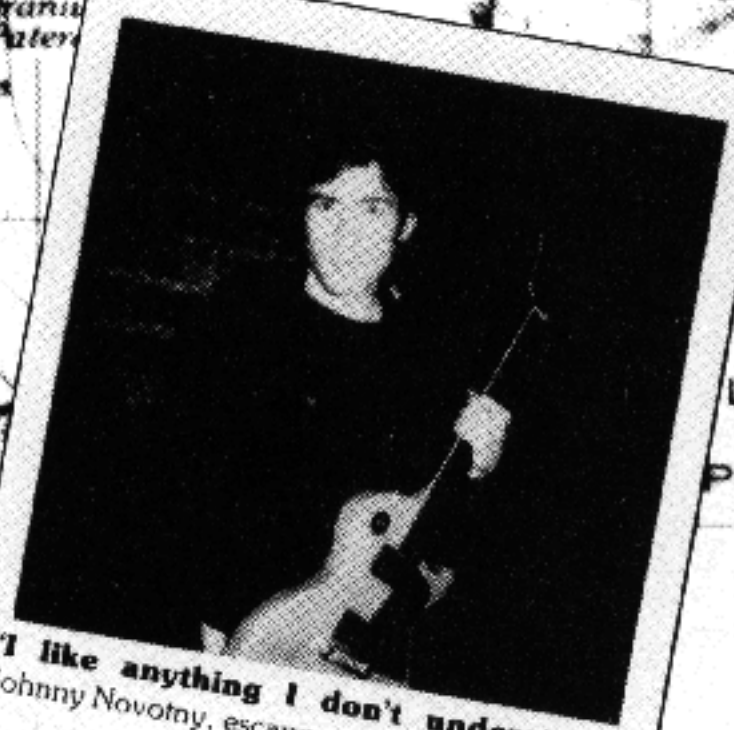

"I like anything I don't understand." Johnny Novotny, escapee.

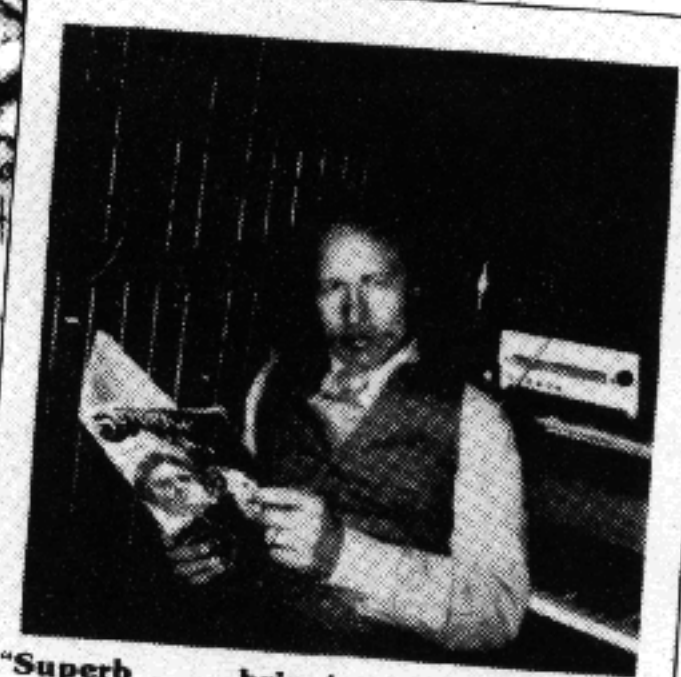

"Superb . . . bringing the synthesizer community together." Don Preston, synthesist.

Inside Synapse you'll find the people, the music, the instruments, the techniques, and the ideas that make up the electronic music world. Featured in each issue are interviews with the most famous and the most obscure musicians, designers, and composers. You'll also find performance and disc reviews, construction projects, technical articles and more.

People involved in all aspects of synthesis have been reading Synapse for nearly two years. Find out what you've been missing. Subscribe to Synapse, now!

international electronic music Synapse

SUBSCRIBE!

Send your subscription order to: Synapse, Subscription Dept. 2:4, 2829 Hyans Street, Los Angeles, California 90026 USA. All orders must be prepaid in US funds.

Name _____
Address _____ City _____
State/Country _____ Zip _____

- If you live in the US:**
- One year/six issues is \$8.00.
 - Two years/twelve issues is \$14.00.
 - One year/six issues by First Class Mail is \$14.00.
- If you live outside the US:**
- One year/six issues by surface mail is \$10.00.
 - Two years/twelve issues by surface mail is \$18.00.
 - One year/six issues by Air Mail is \$20.00.

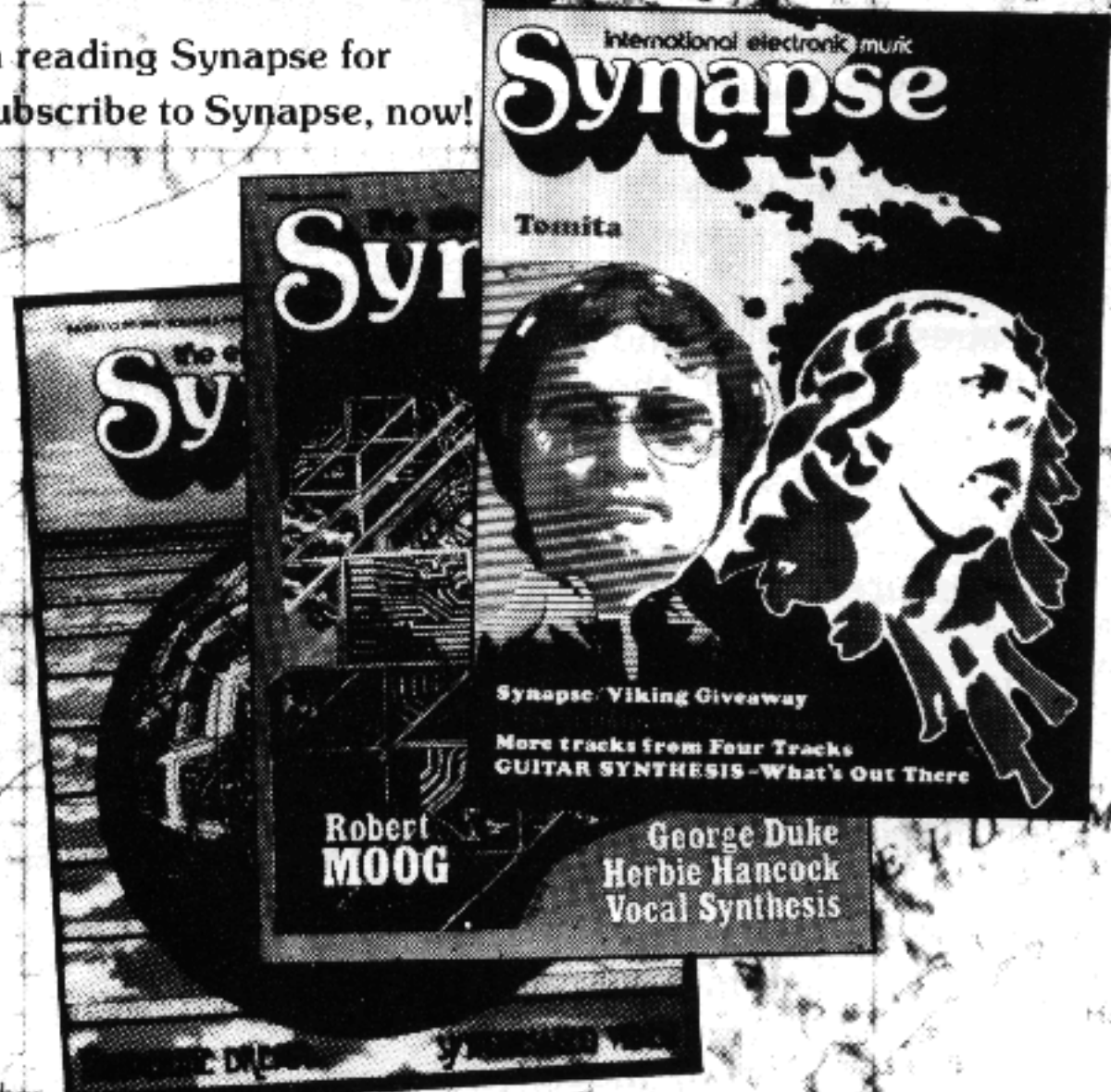

RETAILERS AND DISTRIBUTORS: Synapse is available at discount rates in bulk shipments, by surface or air. Please contact us at the above address or call us directly at (213) 383-7933.

WHAT'S HAPPENING

Continued from page 4
for a bit of American history.

... Sequential Circuits will unveil, at this month's NAMM Western Market Show, a new polyphonic synthesizer named the Prophet. The Prophet is available in 5 and 10 voice versions with 50 programmable pre-sets (programmed at the factory but re-programmable by the user). The unit is controlled by a micro-computer and features pitch and modulation wheels, programs

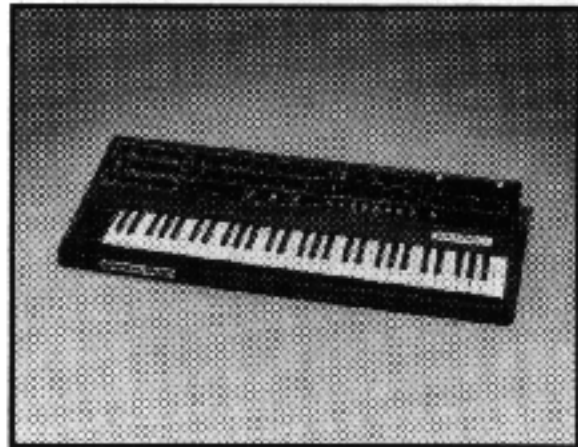

New Sequential Circuits polyphonic Prophet-5.

modifiable in real time, a memory power back-up unit allowing the instrument to be turned off without erasing the stored patches, and a 5 octave keyboard. The 5 voice ver-

sion (10 oscillators) is expected to list for under \$3000.00. Although no retail price has been committed for the 10 voice version, manufacturers' literature states that the conversion from 5 to 10 voices is literally as simple as adding one printed circuit card.

... A new record series featuring contemporary music is being released by Lovely Music, Ltd., 463 West St., New York, N.Y. 10014. Slated for release at this time are, Private Parts by Robert Ashley, Figure in a Clearing by David Behrman, Star Jaws by Peter Gordon, Vernal Equinox by Jon Hassell, Music on a Long Thin Wire by Alvin Lucier, Key by Meredith Monk and Out of the Blue by "Blue" Gene Tyranny.

... If you live in Michigan and you don't know about Michigan Music, a monthly music magazine, you're missing out. It's exactly what every area needs, a media that is not so big that it loses sight of the indigenous music scene. Everything from the Detroit Symphony Orchestra to local club acts are covered. Write to: Michigan Music, Box 724, Detroit, Mi. 48232.

... Wasatch Music Systems has recently released their professional

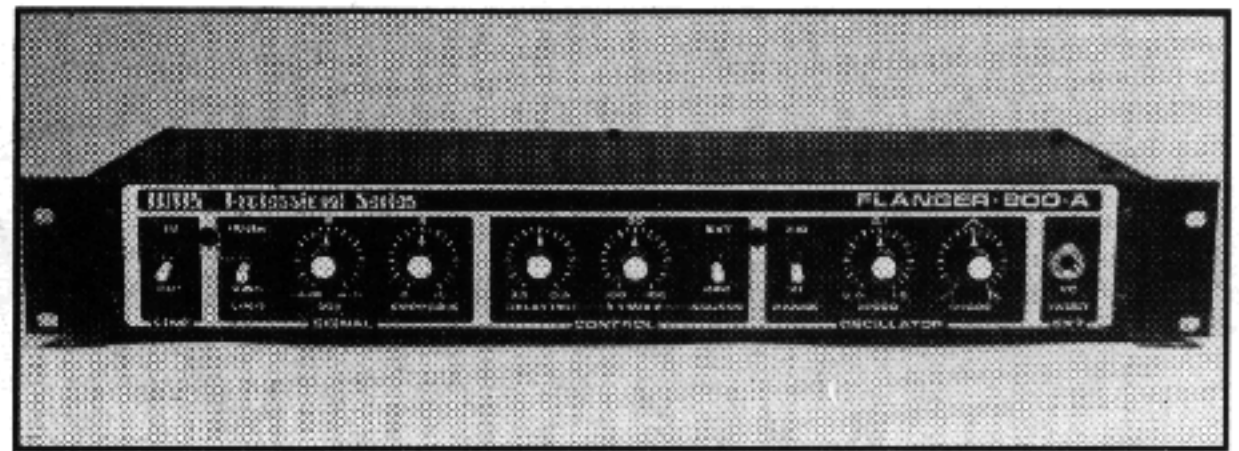

Flanger 900-A by Wasatch.

line of audio devices. Included are the 800-A Dual Band Equalizer, 850-1 Single 28 Band Equalizer, 880-A 6 Section Parametric Equalizer, 900-A Voltage Controlled Flanger, 950-A Voltage Controlled Phaser, and the 990-A Dual Tracking Power Supply. All units mount in the standard 19" racks.

... Solid State Music is marketing a series of chips housing complete module functions normally found in a synthesizer. The first of these chips (designed by E-mu Systems) is the Dual Linear-Antilog Voltage Controlled Amplifier (SSM 2020). Among the applications listed for this \$7.50 chip are, 2 and 4 quadrant multipliers, dividers, voltage controlled filters, companders, and equalizers. The Voltage Controlled Oscillator (SSM 2030) sells for

\$10.00 each and features simultaneous sawtooth, triangle, and pulse outputs; voltage control of the pulse duty cycle; and simultaneous exponential and proportional linear sweep inputs. The Voltage Controlled Filter Circuit (SSM 2040) may be used for the following types of filters: lowpass, bandpass, highpass, allpass notch, biquad, state variable, sallen & key, and cauer, as well as parametric equalizers, phase shifters, and as a sine wave VCO. The chip lists for \$10.00 The Voltage Controlled Transient Generator (SSM 2050) lists for \$10.00 and offers the full ADSR response. The chips offer inexpensive and high quality functions to both professional and personal applications in music and other industries.

Continued on page 10

Synapse

Introducing the new Roland MicroComposer.

You've heard of word processing...and data processing. But have you heard of "music processing?"
With the Roland MC-8 MicroComposer you can store...add to...delete from...re-

structure, and play back through a synthesizer as many as eight voice lines of your own musical composition. And you can do it instantly, as easily as pushing buttons on a ten-key adding machine. We call it music processing.
But that's just the beginning. The list of additional possibilities fills an entire volume.

Roland
The largest, most diversified line of electronic musical equipment in the world.

There's nothing else like the Roland MC-8. It is undoubtedly the ultimate innovation for recordists, musicians, composers and arrangers.



Let us tell you more about Roland's new MC-8 MicroComposer. Write today to Department 10-076, Roland Corp US, 2401 Saybrook Avenue, Los Angeles, CA 90040.

It's quiet and voltage controlled.



If you've had to put up with noisy flangers and phasers and are bored with the standard back-and-forth sweep they offer, then hookup your synthesizer, axe, bass, mic, or keyboard to the most popular sound modifier on the West Coast, the A/DA FLANGER.

Preferred by studio musicians and engineers over digital rack-mount units for performance, dependability and quietness, the A/DA FLANGER's sophisticated circuitry eliminates the "characteristic" background noise found in all other analog flangers. And for extremely low noise applications like recording, the THRESHOLD control may be adjusted to eliminate any minute amount of residual noise without impeding or squelching the original signal.

The only flanger capable of true voltage controlled delay, the A/DA FLANGER may be triggered, swept, tuned to a resonance frequency or modulated with your synthesizer control voltage for an infinite selection of sound effects. Also, you may use our accessory foot pedal, CONTROL PEDAL A, to control the delay time. Other unique features include an EVEN/ODD HARMONICS selector, that virtually doubles the range of sound effects, automatic sweep that may be set between a fast 0.1 second vibrato to a very slow 25 second sweep cycle.

Housed in a rugged sand-cast aluminum case with recessed controls, the A/DA FLANGER has brought flanging, phasing, vibrato, rotating speaker effects, Doppler effects and notch filtering to their ultimate refinement. The A/DA FLANGER, it's quiet and voltage controlled!

Please call or write us for further information and the name of the dealer nearest you.

ANALOG/DIGITAL ASSOCIATES
2316 Fourth St., Berkeley, CA. 94710
(415) 548-1311



Profile: Klaus Schulze

Continued from page 56



record buyers prefer English "poprock" or "American imports."

"Irrlicht" was followed up by a double LP, "Cyborg" and although neither album had real commercial success, their innovative quality was quite marked. At this stage Schulze began to explore the use of new instruments, in preparation for a solo concert career which began with a French tour, followed by a few concerts in Germany. Equipment included Arp's 2600 and Odyssey, an EMS Synthi A, and assorted keyboards by Crumar and Farfisa. In addition Schulze featured a "Sequencer Synthanorma," built by two of his friends.

Nineteen seventy-five saw the consolidation of Schulze's solo career: the release of his fourth album, and a meeting with a Japanese group called the "Far East Family Band," in Hamburg. During the summer Schulze produced their first album, "Nipponjin," which combines the influences of Pink Floyd with a more indigenous Japanese flavor. Schulze however managed to instill much of his own identity into the final product. Around this time, Schulze was working on his fifth LP, "Time Wind," perhaps a milestone in his career, incorporating heavily atmosphere passages.

Moving away from Berlin to the German countryside, Schulze developed a second studio in rather more creative surroundings, and also managed to fit in tours of Italy and Switzerland in the autumn of 1975, and the production of the "Far East Family Band's" second album, this time in England. Perhaps a more significant collaboration was Schulze's participation in Stomu Yamashta's "Go" project. By December 1975, "Time Wind" had entered the French and Dutch charts, bringing a successful close to Schulze's most productive year.

In the first few months of 1976, Schulze devoted time to work on his next LP, and also a visit to England to record the "Go" project with Yamashta, Steve Winwood, and others. In March, "Time Wind" was awarded the "International Grand Prix du Disque," a fine curtain raiser for the sixth LP, "Moondawn," released shortly afterwards. "Moondawn" features Schulze's use of sequencer, thick string and organ statements, and the drumming of Harald Grosskopf. The latter accompanied Schulze in concerts throughout the year. By this stage, Schulze had begun to build up a large following, aided partly by the "Go" concerts which brought him prominence with a wider audience.

Schulze's next project was to score a soft core European skin-flick (released early 1977), the music of which can be found on the album, "Body Love," an interesting experiment involving erotically rhythmic sequencer patterns and flowing string and voice passages. Looking back, I have been somewhat vague on Schulze's actual style of music. Let us begin by quoting Schulze himself: "My music rises spontaneously. I improvise. Experience, technical and emotional, forms the standards, structures of my music, which people signify as my 'style.'" Most of Schulze's compositions are long, usually the entire side of an LP, thus allowing him to develop his ideas fully. Most of his compositions begin delicately, opening with high frequency events mixed with thought-provoking sounds, easing the listener into his own musically cerebral space. From these sounds emerge string synthesizers, played very emotionally, overlaying the other keyboards, which

A Message of Great Importance to Musicians.

Korg proudly announces the most advanced technological achievement in the history of electronic music: The PLS (Professional Laboratory Systems) Polyphonic Synthesizer Group. Developed by some of the world's most brilliant electronic engineers, the Korg Polyphonic Synthesizers mark the dawn of a new age of musical creativity. You've heard that before. But now for the first time Korg's made it true.

The Korg methodology is unique. First, we use synthesizer technology, not a restrictive organ type approach. Then, we don't limit the number of notes you can play simultaneously. The PLS Synthesizers are truly and totally polyphonic. Play all 48 notes at once and you'll experience the thrill of

having 48 mini synthesizers at your fingertips.

Each key triggers its own dynamic filter, envelope generator, and VCA. That means independent articulation of each note. But that's just the beginning. The PLS Synthesizers are modular. Expandable. Totally interfaceable. Patchable. They feature polyphonic, voltage-controlled sample and hold. Plus a host of exclusive, dazzling features we can't begin to discuss.

You'll find the same unparalleled quality, creative technology, and outstanding value in every Korg product. If you're looking for a synthesizer, consider Korg, the keys to creation.

KORG

Another superstar of sound
from Unicord.

75 Frost Street
Westbury, N.Y. 11590

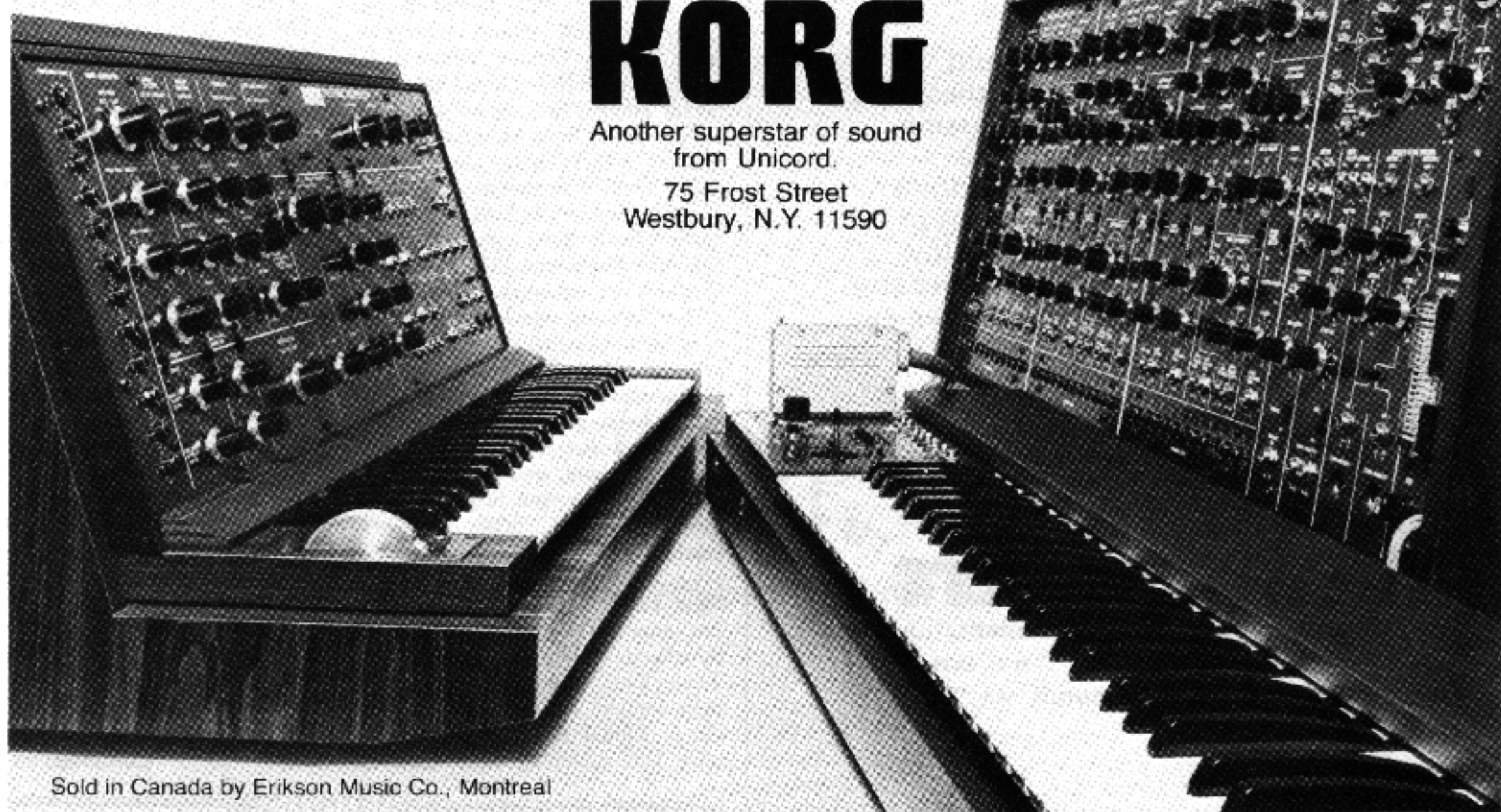

Sold in Canada by Erikson Music Co., Montreal

when you
need something
out of
the ordinary



Looking for something unique in a system? Most of our customers were, before they found us.

There's a good reason for this: if what they wanted was available from other manufacturers, they wouldn't have needed to look us up. Aside from our broad line of standards, we specialize in developing instrumentation not available elsewhere in the market.

If you're one of the great majority of musicians and composers who've never heard of us, you owe it to yourself to get in touch. We'll send a packet of brochures on the synthesizers, mixdown equipment, audio processing systems and modules we carry as a standard product line. If you still don't see what you're looking for, write us or call (206) 542-8041. We maintain a low-volume prototyping facility that can carry your idea from design through packaging.

modules, systems
and prototype designs
for musicians and composers.



wavemakers
kb electronic music instrumentation
p.o. box 27
edmonds, wa 98020

Continued from page 8

provide a background drone. Schulze is aiming at developing another dimension, extended by his extensive use of the echo machine, which serves to enhance his sequencer patterns.

Thus the delicate introduction evolves into a fuller sound, and Schulze expands this with improvisations on lead synthesizer, flowing with key changes of echoed sequences and string synthesizer. He will make subtle or sudden changes in mood, hopefully producing related changes in the thought patterns of the listener.

It is extremely difficult to describe Schulze's music. Because it is highly individual, obviously the best way to understand his style is to listen and judge for oneself. A good reference point would be "Mirage," his latest album, and an excellent example of the growing maturity of emotional content mentioned earlier. Schulze uses a multitude of equipment to paint mental pictures, seen on side one, where he works with a thick layer of timbres undulating into a moving blend of harmonies. Side two opens with a progression of various sequencer patterns and timbres, multi-layered in typical Schulze style, with tasteful use of echo and phasing.

Schulze's own sleeve notes to the album expand this further: "Music to me is the background of a mental picture, but the exact interpretation must be done by the listener. Hence the music is only half composed and the listener himself should attack the composition to gain a mental repercussion." The listener has to add meaning, and as Schulze goes on to say, "Of course my composition is in a basic direction which is my own creativity, but I think it leaves space for interpretation. This is perhaps why people love or hate my music. Some people don't invest into things if no material profit is to be had, unaware of mental joys."

—Steve Roach

Discography

Ash Ra Tempel: "Ash Ra Tempel" PLD 6059, "Join Inn" PLD 6041; Tangerine Dream: "Electronic Meditations" Oh 556.004; Solo LPS Mirage ILPS. 9461; "Body Love" Met. 600.047; "Moon-dawn" ISA. 9001; "Time Wind" CA. 2006; "Blackdance" CA. 2003; "Picture Music" ISA. 9007; "Cyborg" ISA. 9005/6; "Irrlicht" PLD 5095; With Go: "GO TOO" AB 4138; "GO" ILPS 9387; Production on Far East Family Band "Nipponjin" Vert. 6370 850; Photos: Guido Harari, Milan.

Continued from page 7

... Daton, a Swedish synthesizer manufacturer, has released the Daton System 3000 micro-processor controlled synthesizer. Module complement includes: Quad Input Amplifier 3001, Quad Sound Generator 3002, Noise Generator 3004, Stereo Octave Filter 3101, Stereo Reverb Unit 3102, Quad Universal Filter 3101, Quad Envelope Shaper 3104, Ring Modulator 3105, Master Mixer 3201, Sub Mixer 3201, Dual Panorama Unit 3203, Program Sequencer 3301, D-A Converter Bank 3302, and a Force-Sensitive Keyboard 3310. All of the modules can be hooked directly together forming one large board, or may be hooked in different configurations using patch cords. The unit is promoted for use in sound generation, mixing, and editing, as well as a controller for tape recorders, slide projectors, and lighting equipment. The Program Sequencer uses a Motorola MC 6800 micro-processor.

New England Digital Corporation has announced the release of the Synclavier Digital Synthesizer. Their "Basic Digital Music System" includes the New England Digital Corp. Model A Computer System with 16K words of main memory,

one 16 channel digital music synthesizer (with interface), a 61-note C/C Clavier, and a Synclavier Control Panel, with LED digital display. The basic system is priced at \$13,250.00. Featured are 16 digital sound generators, allowing linear FM and 1000 steps per octave resolution. The Analog Distribution Network consists of 4 studio compatible signal outputs, each the sum of 4 synthesizer channels.

... Ultima Thule will perform with the Oberlin Dance Collective on Jan. 28 at the Oberlin Dance Collective Performance Studio, 223 Mississippi St., San Francisco, Cal., (415) 863-6606. The group includes Robert Ostertag-Savage-bass; James Katzin-violin; Richard Rogers-piano. The group says, "One concert might range from compositions in the 'avant garde jazz' genre to non-deterministic piano solos to electronic compositions employing state-of-the-art technology to 'absurd' theatrical devices such as performers eating carrots and drinking wine with contact mics taped to their jaws." When not on the road, the group can be reached at: 150 Elm St., No. 3, Oberlin, Ohio 44074.

Continued on page 56

Synapse



ARP Avatar:

Stolen from the gods of the keyboard.
Bestowed on the disciples of the guitar.

Arp introduces the first full capacity, fully variable guitar synthesizer. Send us a dollar and we'll send you a demonstration record and brochure. Or hear it at your nearest Arp dealer. Say one Hosanna and three hallelujahs.



45 Hartwell Avenue, Lexington, Mass. 02173, 617 861-6000

PERFORMANCE

First Los Angeles Electronic Music Festival

Friday, October 14, 1977
Theatre Vanguard,
Los Angeles

The First Los Angeles Electronic Music Festival was presented Oct. 14, 1977 by the Los Angeles Center for Electronic Music, in association with the Theatre Vanguard in Los Angeles. Electronic music was presented. But it was not a festival. Lest we forget, one concert doth not a festival make.

Tape recorded music and film were pitted against live electronic music as two halves of the program. Surprisingly, the canned events made a good showing. Particularly striking was Joseph Ayooob's *Rhythming*, a pulsating, raucous, metallic machine environment. Two works of sonic slapstick, *Wiener* and *Out of C*, were tightly executed on tape by Reynold Weidenaar. Less satisfying were Daria Semegen's *Arc: Music for Dancers*, which lacked structural direction as well as the dancers, and *Bionic Music* by Justis Matthews, in which tone clusters became tedious.

Rock bottom was hit by two works. Hank Van Draanen's sci-fi *Patchwork* reminded one of Buck Rogers. *That Doggoned Boogie*, switched on by recording engineer Dan Morehouse may have been a put-on or may have been serious. Nevertheless, it was all too accessible, and uncreative.

The film *Bells of Atlantis* was a classical exercise in pretension, but one can forgive the pretensions of Anaïs Nin, Ian Hugo, and Louis and Bebe Barron. Why, I don't know. The other film, of a videotape by Jim Hoegstrom and Paul Koenig, explored David Ward-Steinman's composition with a Putney VCS-3 synthesizer. Entitled *Vega*, the film communicated the mystical qualities of working with a programmable synthesizer, which is increasingly being lost in a world of prepatched keyboard machines.

After intermission, the audience was visited by Philip Loarie as the personification of a robot farm refugee. Wearing monster gloves and feet, flexible tubing for arms and head-dress, and a backpack chock full of electronic gear, Phil gave a short talk in backwards speech, played a short drone ditty on the "digital Dronezilla with

random raga logic" (a collection of digital electronics which spoke through a small speaker at one end of a six-foot PVC tube—audiophiles take note!), and disappeared as mysteriously as he had come.

TRIODE, a group from San Francisco comprised of Chuck Masten, Brian Paul Schindele, and Brett Webster, closed the program with zany theatrics interspersed with competent but undirected electronic music improvisations. The group was plagued by an apathetic Los Angeles audience, unfocused direction, and the Theatre Vanguard's inadequate lighting system. For example, the sacrifice of a cute, stuffed Teddy bear by a sadistic dentist with a Speedbor drill bit was unfortunately in the dark.

The group's strong points are its off-the-wall imagination, competent use of synthesizers, and its cast of bizarre characters, many of whom were played by a fourth member (Drew Anderson), unidentified by an oversight. However, the group needs proper pacing and technical direction to communicate the full potential of its material.

—Eric Valinsky

Performances at the International Computer Music Conference

University of California,
San Diego
October 26-30, 1977

The 1977 International Computer Music Conference featured three formal concerts in addition to an almost continuous presentation of tape music. The first concert occurred at Noon, Thursday, Oct. 27 in the Mandeville Center Auditorium. The surprise appearance of Paul William Simons dramatizing anti-cybernetically poetical sentiments preceded the opening address by Pauline Oliveros, concerning the political role of the artist in society; remarks which were applauded, but soon forgotten during the conference.

The one musical work on the program was *Solo for Bass and Melody Driven Electronics* by David Behrman. Bertram Turetsky played a tiny but sonorous electric contrabass, and Behrman's KIM-1 microprocessor based electronics produced an ever-changing drone which interacted with the bass sounds. The performance communicated the restive qualities

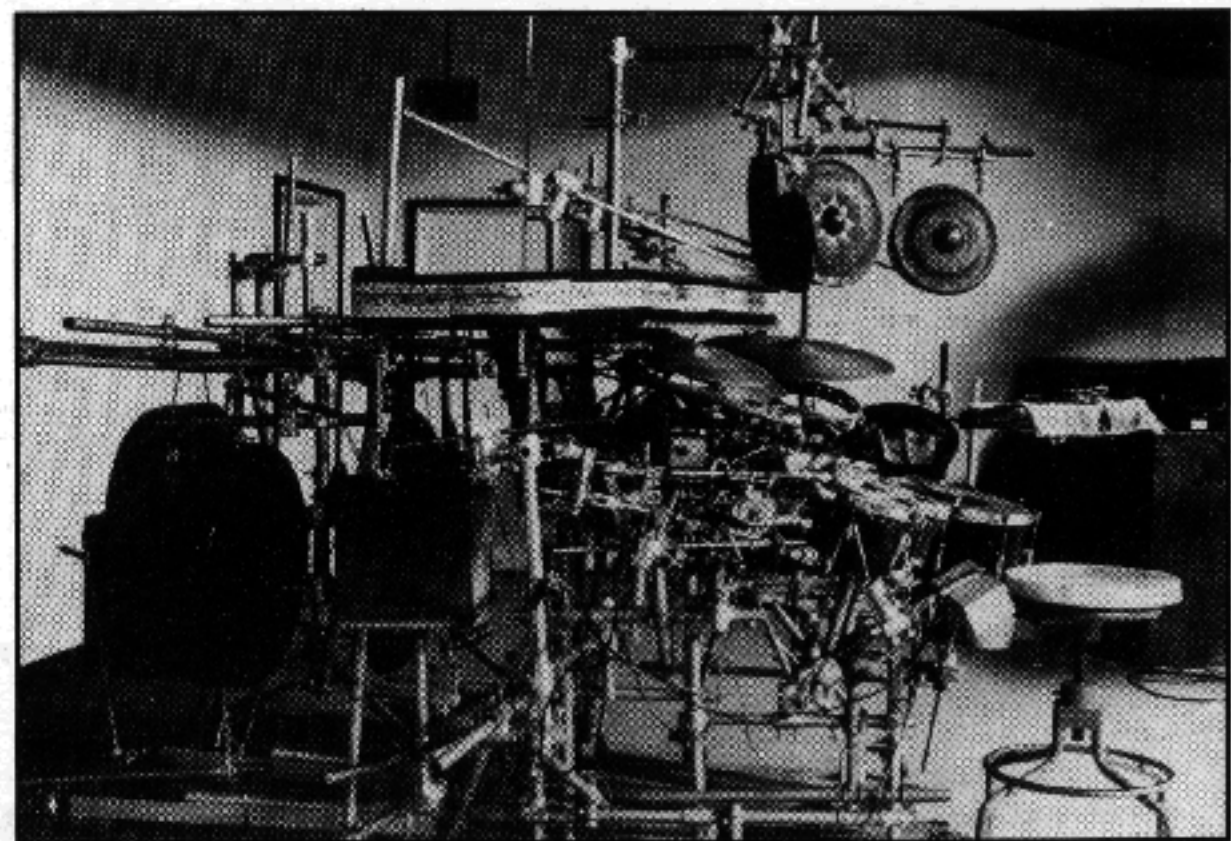

PHOTOGRAPHS BY VIRGINIA QUESADA



That don't look like no computer to me, no sir! Top, percussion machine designed by Ronald George was featured at the International Computer Music Conference. Percussion Loops score can be seen above cymbals. Left, composers Pauline Oliveros and Joel Chadabe. In her welcoming talk Ms. Oliveros remarked that "... without re-examination and embodiment of human values through artistic activity, we fall into a civilization without soul."

of a classical Indian concert, but had little of the excitement.

On Friday, Oct. 28, a concert was presented at the Center for Music Experiment. Two of the works involved extended vocal techniques. In David Jones's *Pastoral*, a setting of the poem by Charles Simic, a single vocal soloist was accompanied by taped sounds, electronic-sounding, but all vocally produced by members of the Extended Vocal Techniques Ensemble. The "Dies Irae" from Deborah Kavasch's *Requiem* featured four soloists with taped vocal background. The absence of the taped accompaniment due to technical difficulties rendered the piece no less electrifying. The composer relied heavily on vocal multiphonics and sub-bass techniques borrowed from Tibetan chant.

Robert Erickson wrote *Loops for Instruments* for six solo instruments which play isolated notes in a complex pattern of steady sixteenth notes. Co-ordination problems rendered performance all but impossible, and John Grey realized the piece electronically at Stanford, employing computer simulated instrument sounds. During this delightful tape, the listener loses his perception of the original instrument sounds and hears instead a pitched quacking. This is all the

more astonishing when one realizes that the Stanford computer simulates instrument tones which are virtually indistinguishable from recordings of real instruments.

A second Erickson piece, *Percussion Loops*, was written for a different class of technology, a huge percussion machine, designed and performed on by Ronald George. Twenty-nine gongs, drums, shakers, castenets, ratchets, and the like were easily played with mallets, and foot pedals controlled three large gongs, a total of thirty-two separate sounds. The machine allowed the performer to make rapid and pronounced changes of timbre, while staying in one place and electrically advancing the score. The piece, well, the machine was the piece.

The energy level descended after the intermission when the KIVA ensemble, consisting of John Silber, Jean-Charles François, and a computer, improvised for what seemed an endless time. François is a frenetic percussionist, and his style was reminiscent of a banging radiator at 3 A.M. Silber's trombone playing was subdued, and had little to do with the equally annoying percussion and computer generated sounds.

Please turn the page

TRADE IN YOUR MELLOTRON

Old Mellotrons are needed for factory rebuilding. To fill the demand, we are offering a liberal trade-in allowance on your old model towards the purchase of a new Mellotron 400 SM or Mellotron Mark V. Or, if you prefer, have your old Mellotron factory converted to new 400 SM specifications. Converted Mellotrons incorporate all of the improvements found on new 400 SM models and are covered by a new warranty. Find out what your old Mellotron is worth. Call or write . . .



MELLOTRON®

A DIVISION OF  **SOUND SALES INC.** Sherman, Conn. 06784
(203) 354-9395

Continued from page 12

Saturday night's performance at the auditorium was presented in two parts. The announcement of the cancellation of the concert due to a power blackout was immediately followed by the restoration of power. The concert was held as planned, but not before several members of the audience and one of the performers left. For this reason, Jean-Claude Risset's *Inharmonique* was rescheduled for Sunday morning. One learned to appreciate the electric medium.

Plot, for percussionist, by Herbert Brun, utilizes a graphic score generated and plotted by computer from a set of instructions by the composer. The performer is required to select his own percussion sounds, which often resulted in impossible sequences which the performer was nevertheless required to execute. In a frantic effort to obey his instructions, Jean-Charles François moved percussion objects quickly from place to place, sometimes breaking them. He, for example, placed a woodblock on a wood drum, hitting the woodblock with a small bell. In a fast paced performance at a discussion session the day before, François generated the suspense of a percussionist at war with a set-up too large for him. On Saturday night, François chose a slower pace. Dramatics became theatrics, and suspense gave way to comedy.

Beginning with hypnotizing organ-like clusters, Jon Appleton's *In Deserto* for computer generated tape conveyed the listener on an exotic journey from section to section.

The other four pieces on the program combined a live performer with tape. Wesley Fuller's academic *Time Into Pieces* for unamplified piano and tape failed to build dramatic interest, despite the pianism of Dwight Peltzer. James Dashow's *Effetti Collaterali* suffered from balance problems, as in many cases the unamplified clarinet, played by Philip Rehfeldt, was overpowered by the tape. On the other hand, Peltzer's barbarous, heavily amplified piano playing was a match for the equally barbarous E major drone of Loren Rush's *Traveling Music*. The piece ended with a grand A major chord of synthesized strings—all that build-up for one full cadence.

Going from the savage to the sublime, Risset's *Inharmonique* featured Neva Pilgrim, soprano. Though her voice was unamplified, it blended beautifully with the computer generated sounds, and with perfect balance. Ms. Pilgrim sang with emotion, but with restraint, with grace, and with beauty.

—Eric Valinsky

Survival Notes:

Copyright Law Revised.

by Barton McLean

Prior to January 1, 1978, the composer of electronic music had only two choices in copyrighting his work. With the first method, he had to produce a visible score, a task often irrelevant (if not impossible). The doggedly determined artist who finally could produce a score analogous to the aural fixations did stand the same chance of copyright protection as the composer with a traditionally notated work. The second method, copyright under Class "N," Sound Recording, only gave him protection for the sounds as they were fixed on that particular record or tape, but not the work itself.

It can be seen that both of these methods were grossly unfair to the composer of electronic music. As the policy decision of the new law states,

"Clearly, we could continue our present practice of requiring the deposit of copies for these works in all cases. Our decision not to do this reflects our awareness of and sensitivity to the problems many contemporary authors would experience if we were to take this position. Traditionally, musical, dramatic, and literary works have been initially preserved in visually perceptible copies. Thus, in most cases, the statutory requirement for deposit of copies was reasonable and logical. More recently and with increasing frequency, however, these works are initially fixed in the form of phonorecords. For example, tape studio music (electronic, "concrete," and tape-music), synthesizer music, and computer-produced music—all creations of the past two decades—are created directly or indirectly on tape. The tape is the composition as well as the performance of the composition. A large number of pop artists and jazz musicians compose by performing the work and simultaneously recording it. Dramatic and literary works are often initially

preserved on tape. The phonorecord is frequently the initial, and sometimes the only, fixation.

"While these musical works theoretically can be transcribed into some kind of visually perceptible form, the transcription is extremely difficult and unsatisfactory in some cases [tape studio music cannot be accurately and completely transcribed] and impractical in others. For some songwriters, poets, and other authors, it is a substantial financial burden to have the work transcribed.

"We believe this decision permitting the deposit of phonorecords in certain cases is a reasonable and logical approach to the transcription problems frequently attendant contemporary creative efforts, and that it is in line with the spirit of the new law which is to simplify registration for the author.

"This decision will be incorporated in proposed regulations."

Let us see how this works. Under the new Copyright Act, any work may be fixed in either a copy or a phonorecord. The work is created at the time of fixation in either form and statutory copyright subsists from that time. "Copies" are defined as "material objects, other than phonorecords, in which a work is fixed by any method now known or later developed . . ." "Phonorecords" are defined as "material objects in which sounds, other than those accompanying a motion picture or other audiovisual work, are fixed by any method now known or later developed, and from which the sounds can be perceived, reproduced, or otherwise communicated, either directly or with the aid of a machine or device" (such a tape recorder). Thus, a "copy" of a work would be its score, and a "phonorecord" would, for the purposes of the law, be either a record or a tape.

The problem for the composer of electronic music in securing copy-

right has always been, as explained above, in the particular form in which it must be registered. Therefore, the specifics of the policy decision regarding the new method of registration should be of interest, and are included below.

Decision:

For registration of claims to copyright in musical, dramatic, or literary works created and fixed in the form of phonorecords on or after January 1, 1978:

1. If the work is unpublished and has been fixed in phonorecords but has not been transcribed or notated in the form of copies: accept the deposit of a phonorecord;
2. If the work is unpublished and has been reproduced in both phonorecords and copies: accept the deposit of either a phonorecord or a copy. Depending on the circumstances, however, the Office may express a preference for whichever form of deposit best represents the work of authorship for which copyright is being claimed;
3. If the work has been published in the United States in the form of phonorecords, but has not been published in the United States in copy form: accept the deposit of phonorecords;
4. If, at the time of deposit, the work has been published in the United States in the form of both copies and phonorecords and the musical, dramatic or literary content is identical in both material objects: require deposit of the form the Library decides constitutes the "best edition" of the type of work in question.

Composers owe a debt of thanks to Dorothy P. Keziah of the Copyright Office and her staff for the fairness and understanding with which they dealt with this question. It is hoped that the whole frustrating issue has been put to rest, at least until the next medium of creative expression rears its head!

THE GUITAR SYNTHESIZER FOR LIVE PERFORMANCE

The two most respected names in electronic music offer the finest guitar synthesizer system available today. The system has the most highly developed guitar controller ever designed... the 360 SYSTEMS SLAVEDRIVER... plus the only fully programmable lead synthesizer... the OBERHEIM OB-1.

SIMPLICITY. The OB-1 is totally programmable—every knob and switch setting you make to create a sound can be stored in its solid state memory. You can have as many as nine patches to choose from. The OB-1 has live performance capabilities that nothing else can touch.

PERFORMANCE FEATURES. The OB-1/SLAVEDRIVER combination provides features that make this *the* optimum guitar synthesizer for live performance:

- Exact octave switching over a five octave range.
- Two independent oscillators, plus sub-octaves.

- Includes *both* two pole and four pole filters for the first time.
- More waveforms available: sawtooth, triangle, pulse, square and variations of each.
- The guitar sound can also be processed through the synthesizer's filter.
- You can slide, bend and even copy note dynamics.
- Expands to a larger system by adding additional synthesizers.
- Includes a keyboard, yet costs less than other guitar synthesizers (that don't have one).
- Foot controls for filter sweeps, transposition, and infinite sustain.

EXPERIENCE COUNTS. 360 SYSTEMS invented the guitar synthesizer in 1972 and has been making refined models ever since. And OBERHEIM ELECTRONICS developed the programmable polyphonic synthesizers that are the professional's choice in the studio and in live performance.



The OB-1 and SLAVEDRIVER component system are what the top session men and recording artists have asked for—a guitar synthesizer that's manageable *and* programmable. Write for the whole story, and the name of the nearest dealer with the OB-1/SLAVEDRIVER System.



360
SYSTEMS

Some Things Are Better Than Others
OBERHEIM ELECTRONICS, INC.
1549 9th Street
Santa Monica, Ca. 90401
(213) 393-0136

Electronics For Live Performance
360 SYSTEMS
P.O. Box 1804
Santa Monica, Ca. 90406
(213) 384-8447

DISCOLA



Utopia Oops, Wrong Planet!

Bearsville BR 6970

Utopia has succeeded in making an extremely good, and very listenable rock and roll album. Unfortunately, in light of their previous efforts, as a band that has stretched this type of music to the limits of experimentation, the album is a disappointment.

"Oops! Wrong Planet" continues in the return to public accessibility that began with "Faithful," and was continued in "Ra." As usual the production and arrangements on the ten songs that comprise the album are excellent. Todd Rundgren's talent in this area really is a benefit to the material which is the best of this particular form. The overall style of the album, a very formulated and polished one both in production and in the material presented, is exemplified by the track "Love In Action." This is a very uptempo piece, complete with a strongly oriented progressive AM style and hook line. Most of the album continues along this style, with "Queen"-like vocal arrangements, that on the whole, because of the talent and experience of the band, work extremely well.

There are a few interesting effects used, such as the treated guitar and synthesizer solo on "Windows." Echo and vocal phrasing are also utilized effectively on some of the other cuts, but this is about as far into the realm of electronic music that Utopia goes this time out. All of the solos, especially Roger Powell's trumpet solo, and Todd Rundgren's sax solo, like the effects, are short, tasty, and to the point.

Below the straight-ahead pop style however, there seems to be a

more conceptual and more dramatic undercurrent trying to emerge. This is suggested by the majority of the lyrics, especially those on "Abandon City," "The Martyr," "Armageddon," and both lyrically and musically on the best track, "Rape of the Young." After extensive and close listening, the concept, along with the title, becomes clearer, expressing the idea that we appear to be on the wrong planet, or at least on a different planet than we had previously known. This is Todd Rundgren's warning of impending world destruction as a result of the present corruption and irrationality of big business, greed, politicians, war and current society in general. One of the problems in the expression of this statement by Utopia however, is that because of the slick arrangements and production of the music, each track is too far removed in style from the body of the work to successfully communicate any large concept at casual, or less than completely thorough listening.

For someone who was "born to synthesize," "Oops! Wrong Planet" is a totally different direction to plunge into so deeply. Utopia has the ability and talent however, to pull off both styles effectively, and it is now simply up to the listener to decide which style he prefers.

—Mark Linden



Peter Baumann Romance '76

Virgin PZ 34897

With the release of the first Tangerine Dream albums, it was very difficult, if not impossible to single out exactly who was responsible for the direction that the material took. Later however, as Edgar Froese began to release solo albums, it seemed apparent that he played this role. His albums very closely represented exactly where Tangerine Dream was at that time.

They contained much more abstract, less melodic material, very much in the slow, flowing style of "Zeit." Eventually, with the release of "Rubycon," through "Stratosfear," the style of music began to change into a much more melodic and structured form. Now, with the release of "Romance '76," Peter Baumann is emerging from Edgar Froese's shadow, and his true importance as an individual artist is beginning to come into focus.

"Romance '76" is a brilliant album that joins together almost all styles of electronic music. The first side begins with a track that could easily have come from the "Stratosfear" sessions. The piece, entitled, "Bicentennial Present," is made up, both melodically and rhythmically, of the best elements of that particular style. It begins with a basic, uptempo rhythm-generator track. Over this track, are off-time, varying syncopations, and beautiful, compelling melodic lines that interweave, forming an exquisite texture that cannot be completely taken in after only a few listenings.

The album however, does not continue in this rigidly structured style. The second piece, "Romance," begins like the first, containing both strong melody and rhythm. Very soon, the melodic line falls away, leaving the rhythm as the repeating foundation, over which melodies and sound textures occur in resurgent bursts, very much in the form of Terry Riley's "A Rainbow in Curved Air." As the two remaining tracks on the first side, "Romance" and "Phase by Phase" unfold, the top lines become more abstract and more emotional, with the rhythm track being the only element that is immediately familiar to the ear.

This process is a preparation for the second side. The first track on this side, "Meadow of Infinity pt. 1," with the addition of the Philharmonic Orchestra of Munich, is the complete juxtaposition of "Bicentennial Present." By now, even the rhythm track has fallen away, and the feeling transmitted, with the use of the orchestra and choir, is a very dramatic one, resembling the "eternal moment" compositions of Stockhausen, in which, because of its less superficial structure, each musical phrase, and each of the forceful climaxes, is a separate entity from the preceding and the following ones, but is just as important and compelling as either of those.

There is little distinction where one track ends and the other be-

gins on Side 2. "The Meadow of Infinity" continues into the "Glass Bridge," which midway through, develops a steady rhythm line that previously had appeared to be one of the many brief phrases. The acoustics of the piece are so closely related to tympani and drums that it is hard to tell that the orchestra is no longer playing, and that the percussion is synthetic. "The Glass Bridge" then moves smoothly into "Meadow of Infinity pt. 2," in which the flowing and meshing of the musical phrases that seemed so separate in the first part are combined, and their connection and similarity when combined in this way, is astonishing. The emphasis is again on many interweaving melodic lines, and complex chordal and rhythmic textures, but rather than uptempo and quick, they are full, slow and meditative.

It is extremely difficult to attempt to put so many styles into one album without getting a very schizophrenic effect. Peter Baumann has not only overcome this obstacle, but has done it in a beautiful and cohesive way, which is incredible.

—Mark Linden

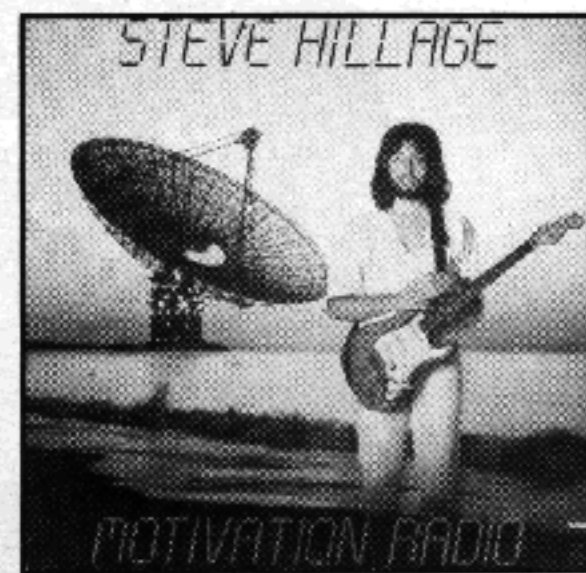

Steve Hillage Motivation Radio

Atlantic SD 19144

There have been many movements responsible for the development and progress of music. One of the most creative and musically important movements has come out of Canterbury, England in the late sixties, and has resulted in the formation of a string of progressive, electric/eclectic groups like Soft Machine, Caravan, Egg, Mike Oldfield, and the group/lifestyle, Gong. Steve Hillage has been associated with all of these groups, and through them, has gained accept-

DISCOLA

ance as an excellent and diverse writer and guitarist.

Hillage's personal vision that he attempts to communicate through his music is a revelation of the coming of the new cosmic age, and the new global awareness. He began this with his first beautiful and much overlooked solo album, "Fish Rising." Following this was his American breakthrough "L," possibly one of the most important fusion albums of electronics, rock and jazz in the last few years. Now, he has taken a new direction with "Motivation Radio."

One of the most striking differences in the progress and change throughout the three albums is that each has dealt more with separate tracks and less with an overall unity of tracks. "Fish Rising" contained a total concept throughout its entirety. Tracks on "Motivation Radio" however, are not at all connected with each other. Partially because of this lack of connection and of the inclusion of too many influences, the album has a slight feeling of disunity and lacks the purposefulness that was so important to "Fish Rising" and "L."

One of the most probable reasons for this feeling, is the use of Malcolm Cecil as producer. Cecil is best known for the production and synthesizer work that he has done with Stevie Wonder. His style of production and the funk influence of bassist Reggie McBride and drummer Joe Blocker's playing seem slightly out of place in Steve Hillage's futuristic setting. This gives a jolting and almost disjointed feeling to tracks like "Motivation" and "Octave Doctors." On the other hand, the resurrection of Malcolm Cecil's legendary synthesizer T.O.N.T.O. (The Original New Timbral Orchestra), which he originally displayed with Robert Margoueff on the LP "Tonto's Expanding Headband," adds a lot to Hillage's inclusion of electronics on the album.

This incorporation of electronic elements, along with his excellent guitar playing, is one of the distinctive and truly important talents of Steve Hillage. This is especially refreshing when multitudes of bands use synthesizers as strictly another type of keyboard or for nothing more than sound effects. Hillage utilizes a wide range of both guitar synthesizers and sound synthesis to enhance the feeling and range of his music and outstanding guitar playing rather than to totally alter it. The best example of this is a breathtaking acoustic/electric solo at the beginning of "Radio." The glissando and sound synthesis techniques are

very subtle, yet greatly contribute to the spacey, meditative feeling of the piece. Extending over many other styles are the fiery, lyrical, jazz solos in the opening track, "Hello Dawn," and "Searching for the Spark," the fusion styles of which are reminiscent of some of Hillage's early work with Gong. Also compelling is the searing, synthesized guitar solo that opens Hillage's startling transformation of Buddy Holly's "Not Fade Away." Another example of Hillage's diverse mastery of styles is the sleek, textured "Light in the Sky," a relentless heavy metal riff song that is one of the most superb attempts of mixing hard-edge rock and roll with the melodic elements of more progressive music.

Steve Hillage is one of the most talented musicians to emerge in this decade, and while "Motivation Radio" is not his best work, it still contains technical brilliance and stunning, inner beauty, along with an uplifting new age vision and optimism.

—Mark Linden

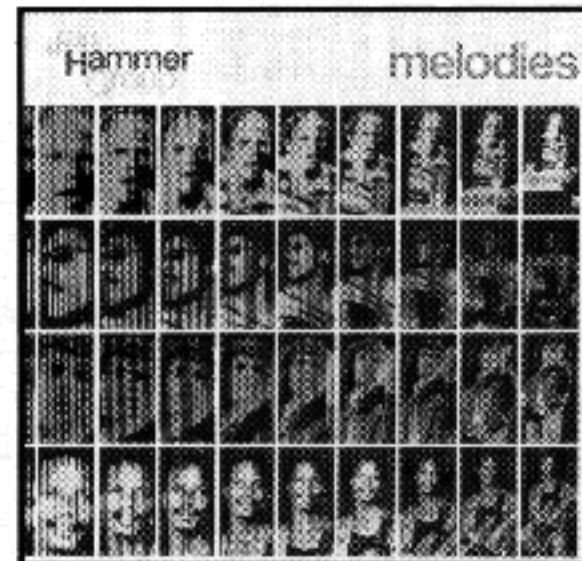

Jan Hammer Group Melodies Nemperor 35003

The Jan Hammer Group has been together in this configuration for three albums now (one with Jeff Beck, live), and they are tighter on this album than ever before. Jan Hammer and violinist Steve Kindler duel ferociously and Tony Smith and Fernando Saunders back them solidly on vocals, drums and bass. The sound is good, although it would be better if they had recorded the drums in a better studio.

There are lots of hot licks on Hammer's Minimoog/Oberheim combination (Hammer has to be the master of the pitch wheel), and on the Oberheim as well.

But all those vocals! It seems like they are making a half-hearted attempt to become more commercial by adding more vocals (on "Oh Yeah!" there are two vocals and seven instrumentals—on "Melodies," nine vocals and two instrumentals). It's no secret that record companies like vocals, but in pleasing the record executives, they may lose their audience. There are some cuts that match the warmth of "The First Seven Days" but nothing with the burning urgency of "Red and Orange" (from "Oh Yeah") or "BlueWind" (Jeff Beck's "Wired" or "Live"). Mostly mellow, not enough funk to be funky, not enough jazz to be jazzy, and they're light years from Fleetwood Mac. It's too bad. These guys are great. To put out an album as mediocre as this one doesn't do anyone any good, least of all them.

—Danny Sofer



Donald Knaack Donald Knaack- Percussionist John Cage: 27'10.554" Marcel Duchamp: The Bride Stripped Bare By Her Bachelors, Even. Erratum Musical Finnadar SR 9017

There is a discrepancy in the music world between "electronic music" and "synthesizers". To the layman, the term "electronic music" denotes a general area of music the same way "classical music" denotes not only classical, but the baroque, romantic, and impressionist periods as well. It is not this vague, general term "electronic music" but the more specific style "electronic music" that contains the controversy. By "electronic music," I mean the style of organized randomness, performed with combinations of timbres not usually found in an orchestra or rock band, with long periods of silence separating clusters of rapid-fire sounds that are rarely pitched.

The discrepancy is that this "electronic music" does not have to be performed with electronic instruments. While Subotnick and Babbit realize this type of music with synthesizers, Cage and Xenakis have written the same sounding music for pianos and orchestras. While it may be true that Stockhausen "invented" electronic music, it was Edgar Varèse who defined its style with his small ensemble pieces in the twenties and thirties ("Octandre" and "Ionization"), and again with his "Poème Electronique" in the fifties.

All of this classical electronic music has nothing whatsoever to do with Walter Carlos, Keith Emerson, or Tomita, who play conventional

continued on page 53

New Releases

Vangelis
Spiral
RCA PL25116(UK)

George Duke
Reach For It
Epic JE 34883(US)

Emerson Lake and Palmer
Works Vol. 2
Atlantic SD19147(US)

Genesis
Seconds Out
Atlantic SD2-9002(US)

Alphonso Johnson
Spellbound
Epic 34869

Gary Wright
Touch and Gone
Warner Bros. BSK 3137

Sensations Fix
Vision's Fugitives
All Ears SF 11478

Chronicle
*... Like a Message
From The Stars*
All Ears CH 11477

David Bowie
Heroes
RCA AFL 1-2522

Tangerine Dream
Encore
Epic PZG 35014

Iggy Pop
Lust for Life
RCA APL 1-2488

David Rosenboom:

Recent Cybernetic Insights

by Bob Davis

David Rosenboom is one of the most technologically sophisticated musicians in contemporary electronic music. He is perhaps best known for his work in the area of combining bio-feedback with synthesizers. For this he received recognition in places like *Electronic Music, A Listener's Guide*, by Elliott Schwartz; *The Development and Practice of Electronic Music*, edited by Appleton & Perera; and *Experimental Music*, by Michael Nyman.

While at SUNY at Buffalo, where he was a Creative Associate in the Center for Creative and Performing Arts, he played viola on the recording of Terry Riley's very influential "In C." This year he is on leave from his position on the faculty of York University in Ontario, Canada and living in Berkeley.

One of David's ongoing activities is his work with ARC. In Canada this stands for the "Aesthetic Research Center" in Vancouver and Toronto. This is a collective of David and John Grayson, with others, on particular projects such as publishing books and records. Some of the collaborators include Michael Byron, J.B. Floyd, and Walter Zimmerman. More will be spoken of this group's activities later. The Berkeley ARC is an independent, but allied organization. ARC in this case stands for "Artists' Research Collective" which is "essentially" David Rosenboom and Don Buchla. Much of this collaboration is at present devoted to the further development of David's personal analog/digital electronic music instrument.

Like so many currently concerned with the live performance of electronic music, high on his list is getting "gestural information into the instrument." Rosenboom: "All the developments of electronic music lead us to a certain point where we have a vastly expanded pallet, but the means of controlling that pallet remain relatively unexplored. There are two areas which I think are really hot right now. Areas which really need work and where the work is going to happen. They are, of course, all of the realtime compositional procedures made possible by the development of digital control through hybrid systems, and the other comes from some of the results of the intensive study of output forms of the nervous system leading to physiological interface with an instrument. I'm not saying that one is always going to be wired to a system, I don't mean that. But, by studying the output forms of the nervous system one can learn and see ways to make intelligent input terminals to an instrument that can extract the nuance of gesture."

Besides the interface with brain signals, David has written routines in software which derive "touch signatures" from performers on the instrument. Rosenboom: "If you extract a lateral and a vertical pressure curve from the action of touching a sensor and think of it as a

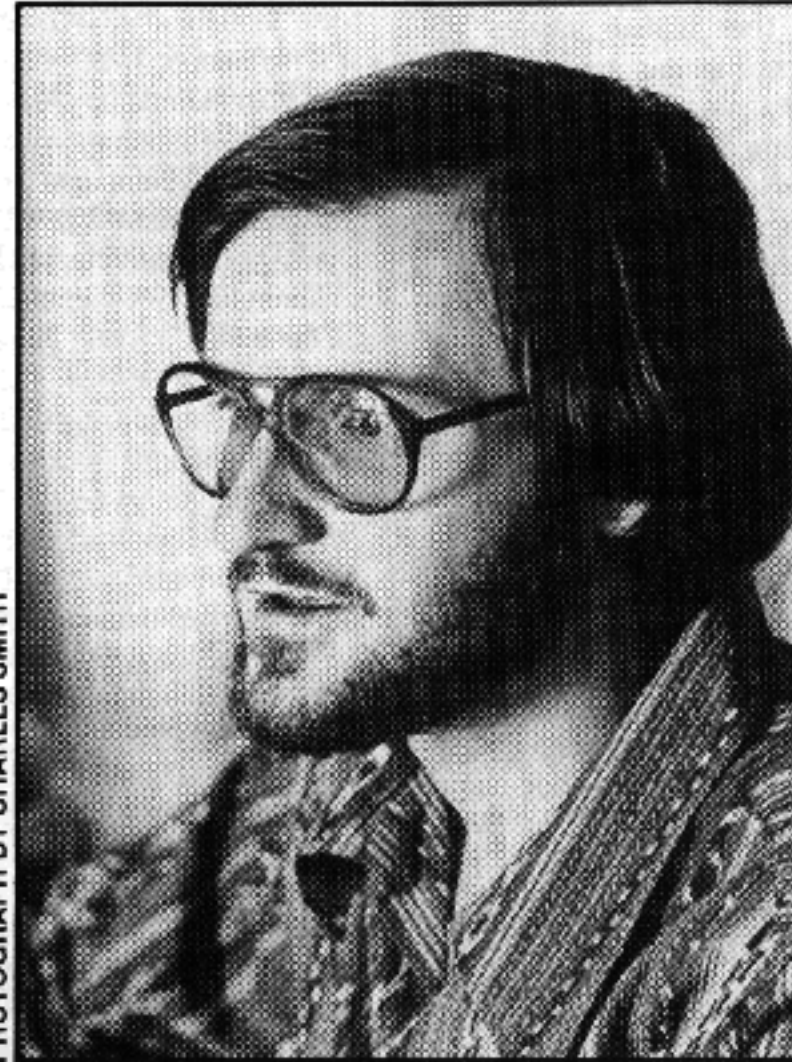

PHOTOGRAPH BY CHARLES SMITH

"I'm not saying one is always going to be wired to a system..."

kinesthetic input to the system, then you can use routines which will take advantage of the fact that the forms of touch that are associated with types of expression are relatively constant over a wide range of humanity.

"Some people might have heard of Manfred Clynes' work. He is a psychologist, neuroscientist, and composer who's done a lot of work analyzing output forms of the nervous system. He found, for instance, that when people touch sensors with the intention of expressing certain emotions or keeping time to music of certain composers, they produce a pressure curve or 'signature' which is relatively constant."

Bob Davis: "In other words, someone wiggling their finger along with Beethoven is going to look pretty constant and different than Stravinsky?"

David Rosenboom: "Right, especially assuming that they're somewhat familiar with the

music. The point is not that everyone will have exactly the same output form, but if there are these constants, even if it's within an individual alone, it makes some sense to use a computer-type procedure that can learn to recognize characteristic touch shapes.

"The idea is to use a pattern recognition routine that teaches itself. As you play it more it gets increasingly used to your feel. So, if you can define the action of touching a sensor with a particular gestural form as an arbitrarily programmable stimulus to the system, then you have an increased range of stimuli recognizable by the system from touching the same sensor."

This ability of the program to recognize similarities in signals from the human nervous system is similar to a technique used by David on a recent recording. On February 12, 1977, before ARC Berkeley began building new boards to incorporate newer ideas into the system, there was a performance in Toronto at The Music Gallery. A recording of this performance, "On Being Invisible" is available through Music Gallery Editions (MGE 4, 30 St. Patrick St., Toronto, Ontario.)

On side one of this recording, brain signals "are subjected to an auto-correlation analysis used to extract patterns from the brain signals that tend toward regularity. This is done by comparing the sampled signal to many stored versions of itself that are incrementally delayed in time. This determines how closely the patterns present at any given moment are related to patterns that occurred in the recent history of the signal. These detected patterns are used to influence the flow of musical time, rhythm, in the production of melodic contours, and in the generating of clouds of timbral relationships in, especially percussive, 'instruments.'" This comparison of a signal with its own history is done in order to find aspects which tend toward stability. These meaningful elements are then converted to coherent voltages which influence the compositional routines used in the performance.

Another type of analysis program is one which looks at the envelopes of different frequency ranges of an input and produces voltages which correspond to these envelopes. One composer, Charles Dodge, has done quite a lot of work in extracting speech synthesis parameters and applying them to other computer generated sounds.

The final application of the digital technology is the ability to call up pre-composed "instruments" or patches. Among the circuit boards is a "control voltage matrix" which controls the routing of control voltages from outputs to inputs. It also specifies fixed or time variant control voltages and can multiply inputs by a scale factor. Rosenboom: "This system can create arbitrarily complex control voltage functions or wave forms within the audio range. . . . The only limitation is the size of the memory of the computer. You have the ability to specify the point to which a particular function should go

and specify how long it should take to arrive there. So it could be instantaneous or it can be delayed for some time. You set the process in motion. The interface hardware does the time interpolating and when it arrives at the specified point, it sets a flag which tells the computer that it needs more data or stops, or whatever you want it to do. These points in the arbitrary function can also be stimuli for other things because they are easily identifiable in software."

When asked how all this is accomplished, David said, "The actual hardware consists of the Interdata mini computer, and the video terminal and keyboard, and then the translations into musically meaningful controls come from a variety of circuit boards attached to the computer's data buss. Among these are the control voltage matrix." The analogue synthesizer's sound sources are not "traditional oscillators, but complex waveform generators. Within what we used to call an oscillator module you have the capability of controlling various aspects of timbre and precise control over all the modulation functions. So there are really two wave form generators in each 'oscillator' module. This means that all the FM or AM routines can be done right in the module. They really are complex wave generators. The whole idea of multiple oscillators in the traditional, studio sense, I think, is on the way out. With the kind of flexibility that software control gives you, (given that, of course, your wave form generator is really well designed and the one I'm speaking of is Don's newest design and it's really beautiful), it's easy to make a fantastically powerful instrument out of each one. You don't really need lots of oscillators in order to get spectral richness or even some polyphonic things because the module can be time multiplexed if you want it to. It can go real fast and produce several voices with the digital control. But the idea of getting a sound source that is as meaningful to play as an acoustic instrument seems to be more important than having a lot of oscillators."

The circuit boards which accomplish the neurological signal interface and the software generation used in this system are David Rosenboom's design and construction. The hybrid synthesizer and its interface to the computer are Don Buchla's. At the time of this interview the instrument itself was awaiting reconstruction by Berkeley ARC.

The construction of this instrument is the work of Buchla & Associates and the Berkeley ARC, but the ARC in Canada is working on very different projects. David describes the original founding of ARC by John Grayson. **Rosenboom:** "John, who has been a musician, sound sculptor, is also a catalyst for things. He organizes a lot of important meetings, computer conferences, and sound sculpture shows. He was working at a place called the Cowichan Center for Gestalt Learning, which was a Perls institution when it first started. He came there as the music director. And as that wave of activity passed its peak, John transformed and reconceived of it as the Aesthetic Research Center (ARC). He and I had gotten to be good friends by that point and we both had similar goals and fantasies about the whole thing. First we were into things like summer workshops and shows, and then we got into publishing, and this has slowly become the major activity."

"In order to get it started John had a small grant from the Canada Council to produce his sound sculpture book. I don't think it anywhere near paid for it, but it helped. And the rest of

Continued on page 42

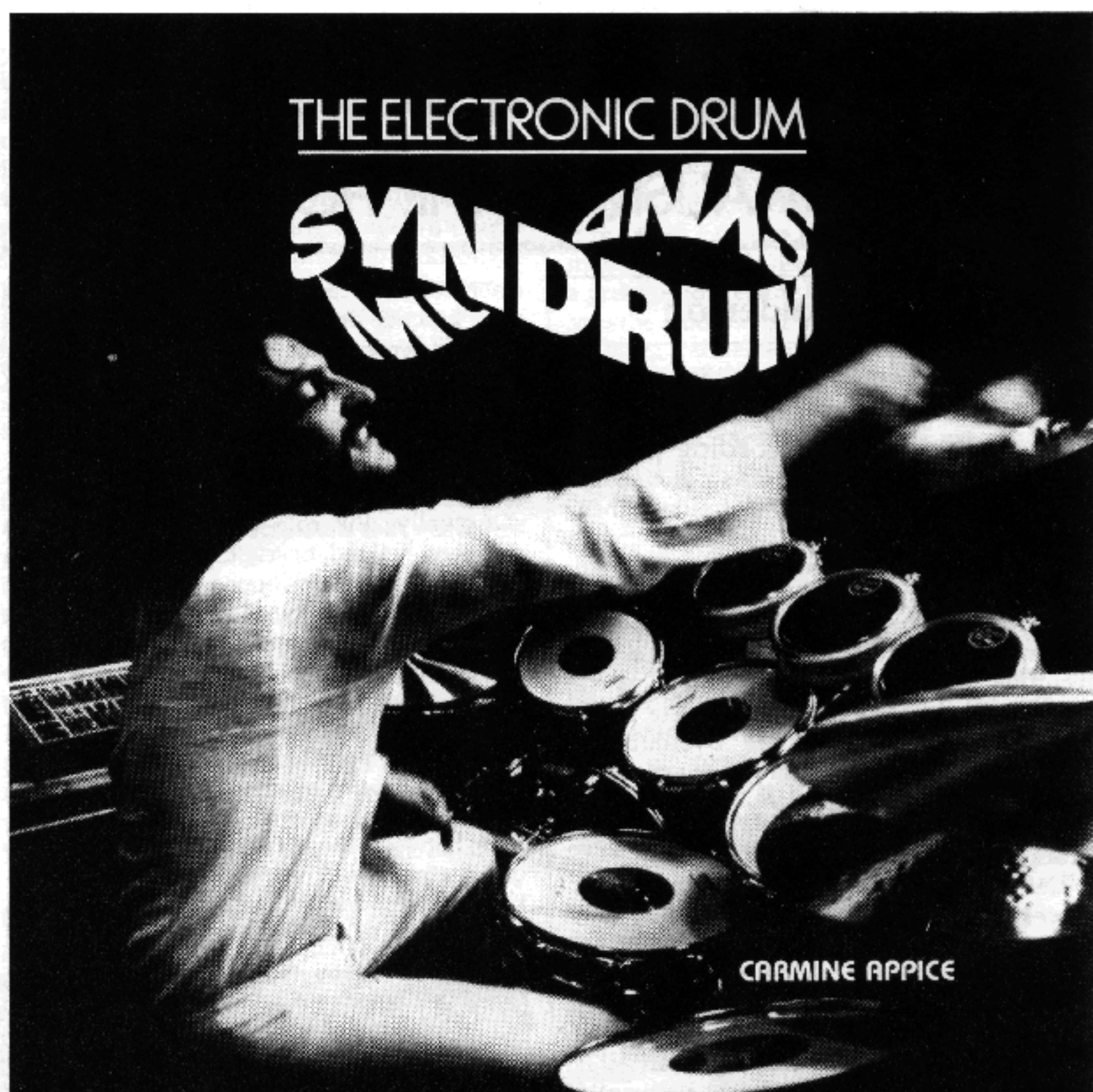

THE ELECTRONIC DRUM

SYNDRUM

CARMINE APPICE

PERCUSSION WILL NEVER BE THE SAME

Syndrum is a totally new approach to percussion. Whether used singly or in sets of four or more, Syndrum allows you to totally exploit the possibilities electronics offers the drummer. And the variable controls of Syndrum allow you all the options of electronic percussion without sacrificing technique. It is this concept of dynamics and control that distinguishes Syndrum as a musical instrument for the drummer. The professional acceptance of Syndrum is unprecedented as the following list indicates:

Carmine Appice (Rod Stewart)
John Barbetta (Jefferson Starship)
Hal Blaine (John Denver, Studio)
Mike Botts (Bread)
Terry Bozzio (Frank Zappa)
Barry Brandt (Angel)
Gerard Boudry (Donna Summer)
Bill Curtis (Fatback Band)
Les DeMerle (Transfusion, Studio)
Graham Edge (Moody Blues)
Phillip Ehart (Kansas)
John Guerin (Studio)
John Hartman (Doobie Brothers)
Evan Kaplan (L.E.M.)
Keith Knudsen (Doobie Brothers)
Russ Kunkel (Section)

Gary Malaber (Steve Miller)
Ed Mann (Frank Zappa)
Jerry Maratta (Peter Gabriel)
Rick Marotta (Linda Ronstadt, Studio)
Ralph McDonald (Studio percussion)
Derek Pellicci (Little River Band)
Jeff Porcaro (Studio)
Dan Pucillo (Robert Goulet, Studio)
Tom Radtke (Studio)
Michael Shrieve (Automatic Man, Studio)
Mark Stevens (Dinah Shore Show, Studio)
Studio 55 (Richard Perry & Howard Steele)
Jan Uvena (Symphonic Slam, Studio)
Lennie White (Studio)
David Williamson (Clinician)

And more!!! Current & soon to be released albums featuring Syndrum include those of: Linda Ronstadt, Hall & Oates, Carly Simon, Boz Scaggs, Roger Miller, L.E.M., Alphonso Johnson, Doc Severinsen, Rod Stewart, Diana Ross, Doobie Brothers, Leo Sayer, Tim Weisberg, Seawind, Ralph McDonald, Jackson Browne, and The Steve Miller Band.

For a complete Syndrum Owner's Manual send \$1 to
Pollard Industries, Inc., 9014 Lindblade Street, Culver City, California 90230.

PRODUCTION

PROFESSIONALISM IN THE HOME STUDIO

by Craig Anderton

Many musicians have taken advantage of the availability of low cost multi-channel recording equipment to create their own home studios. Until now, musicians could only formulate their musical ideas with the help of other musicians, or by renting time at a commercial (and often expensive) recording studio. Now there is an alternative: having easy access to a home recording studio not only allows the recording of musical groups, but allows a single musician to become a complete musical entity through multiple overdubbing techniques (see two of my previous articles in *Synapse*—"What to Do Until the 4 Track Arrives" Vol. 1, No. 5, and "Getting More Tracks from 4 Tracks," Vol. 2, No. 3).

Unfortunately, a number of musicians enter their home studio without having had the experience of working in professional studios, and without having had the benefit of working with knowledgeable engineers and producers. I've had the opportunity to listen to many amateur home tapes, and this lack of professional experience frequently hampers the overall quality of sound. One of the biggest differences between amateur and professional tapes is the style of production. We've all seen producer credits on the back of albums and tapes—but what does a producer really do, and how can we apply a producer's magic touch to home tapes?

In this article, we will examine both aspects. Part 1 will cover production techniques during recording, and Part 2 will discuss techniques applicable to mixdown and assembling of tapes.

Why Learn About Production?

In addition to creating more professional sounding tapes, good production can turn unfocused pieces into musical events of greater power and scope. Also, playing live and playing in the studio require very different attitudes and techniques. Good production can help ease the transition from stage to tape or vinyl and get the most out of the studio.

Traditionally, the producer is an objective voice in the studio, often being the link to a record company (or whoever is paying for the studio time). When sitting in your own home studio it's a little harder to be objective about your own work, but it's worth the effort. The ability to transcend your own outlook to a more objective, production-

oriented overview is a skill that increases with practice and improves your all-around musical perceptions.

What Exactly Is "Production"?

Actually, the role of a producer is not strongly defined or rigidly categorized. At one extreme, a producer will take an artist and choose the material to be recorded, the studio, an overall concept for the album, the direction of the mix, and perhaps even some of the promotional aspects. And the other extreme, you can have a producer who just lets an experienced artist do his or her thing with a minimum of interference . . . as long as everything goes well.

In between these two extremes there are other aspects of the producer's job. Sometimes the responsibilities are psychological; a particular artist may be underconfident and



Craig Anderton in his favorite working place—his home studio.

afraid of the studio, in which case the producer can inject a good dose of morale, much like the managers of sports teams. Sometimes the opposite is true, and the producer must prevent an artist from getting carried away and over-emoting.

Other responsibilities can either be farmed out to specialists or absorbed by the producer. A good example of this is arranging (especially the ubiquitous string and horn parts found on 45s). Some producers do their own work; others hire arrangers. Some producers are very involved with the engineering of a piece of tape, with the engineer more or less relegated to the position of tape operator; other producers work in close harmony with an engineer.

The problem in a home studio is that you can't have arrangers, producers, and engineers hanging around; so you have to assume

these various identities yourself. Let's discuss specific techniques that demonstrate what you can do to improve the production on your tapes.

Before You Start Recording

Spend some time thinking about the piece you are about to record. First, *write down* the overall mood or feel you are trying to communicate. The reason I believe in writing it down is because as the tape progresses, you might start losing sight of what you intended to accomplish; with an objective stated in writing, you have a good reference point to refer to as the music unfolds.

Next, put on your arranger's hat. What instruments, or combination of sounds, will help get across the result you want? Naturally, you cannot anticipate everything before you start recording, but give the matter as much thought as possible.

Finally, before you start to record any tracks think about your track strategies. Since most home studios are based around a 4 track recorder, and since you will often want more than 4 tracks total, you must plot the order of recording tracks. It's always a drag to realize you have two more overdubs to go, with no place to put them . . . so plan ahead.

I'd like to emphasize that all this planning is just that—planning, not execution. You must retain the flexibility to change in mid-stream if the music requires it. A good analogy is planning a road trip. You plot out your direction with the aid of a map, and anticipate what route you wish to take. But should you notice an interesting detour, or run into a traffic jam that needs to be circumvented, you always have the freedom to deviate from your original plan.

While You Are Recording

One of the most valuable functions of a producer is to give you constant feedback about the quality of your musical performance. The better a producer knows you, the better the advice offered; the producer will know if you are capable of giving a

better performance, or will know when you've hit your technical limit. Here is one situation where it is very difficult to be your own producer, since it's tough to maintain absolute objectivity over your own creations. But you must work at it, in order to reach that delicate compromise between just going with the very first take and going over something again and again and again and again and again in an attempt to reach "perfection." For example, let's say you play a tremendous synthesizer part except for one small error. Do you redo the part? Do you accept the error? Do you try to cover up the error? Only you can decide. Another example concerns the limits of endurance while playing. I often find in my own playing that I will play a part a couple of times just to get the feel for what I'm doing; then, my playing of that part will improve over the next several attempts, until it reaches a peak. Then, any more playing and performance starts to go downhill—probably due to a combination of tiredness and excessive repetition. Part of the role in producing myself is to catch that exact moment when my playing is at its peak, and saying, in effect, "that's it." Trying to go for something better can often result in something worse. Sometimes you can keep a part in one track and record an alternate part in a vacant track, but many times there is no vacant track when you need one the most.

Players frequently get into a rut trying to perfect a particular part. Although the part may be technically correct, there can be a loss of spontaneity and excitement which dulls an otherwise good track. In a case like this, try switching directions completely in your playing—chances are you will come up with something fresh that will contribute more to the feel of a piece than a technically perfect, but emotionally sterile, rendition.

There are several sides to the "feel vs. technique" controversy. Some producers believe very strongly that feel is the most important quality to have on a tape, regardless of technical considerations. These producers are looking mostly for an emotional impact from a piece of music, rather than specific musical values. Other producers have no reservations at all about doing a part over 20 or 30 times in a row to achieve a clean paragon of perfection. In my opinion, the ideal producer has the flexibility to know when to go for impact and when to go for technique. Don't be too fast to erase a superb bass part because of one little error—chances are, after you have completed the various other tracks, any error may not even be noticeable. But if there is a glitch that really bothers you, it's best to do another take. Once recorded, an error is on that tape forever . . . and if it bothers you now, it will probably bother you forever also.

A producer must also decide how to record a particular sound or instrument. Many times the safest approach is to record an instrument "dry"—that is, without any effects or modifications; the theory is that this gives maximum flexibility during mixdown. For example, if you record a bass with a certain

effect, you may find out while mixing that you didn't really want that effect after all, but now you can't get rid of it without redoing the track. On the other hand, recording everything "dry" can raise problems since it is impractical to relegate too many tasks to the mixdown process. If you only need to add static treatments during mixdown (like a bit of tone color change or reverberation) it won't distract you from the chores of mixing. But if you have to raise the level in one place, lower it in another, then punch in an effect—you're going to need 14 hands to mix, and it would be better to record the track with those changes already present.

Perhaps you have heard the phrase "we'll fix it when we mix it." Here's an example: you are playing an instrument that generates some hum. While you're playing, the hum is covered by your notes, but it becomes apparent during breaks in your playing. If the producer is in a hurry, he might say "we'll fix it when we mix it," meaning that the hum will be edited out during the mixdown process by, say, turning down the track level when you aren't playing. Again, this has its uses, but don't leave too much up to the mix, or you will find it virtually impossible to devote your full concentration to the sonic balance.

A good producer will also know when the session is over. Musicians feel they can play all night, and are usually hard to pry loose from the studio. But there is a point where fatigue takes over, and efficiency

drops dramatically. Being in the studio can take a lot out of a musician, what with the repeated playing, extended periods of concentration, and so on. It's best to know when you've had enough, so you can get back to your music again with a fresh outlook.

Speaking of having enough, that should do it for Part 1 of this article. One point worth mentioning in closing is that no producer was a great producer the first time he or she went into the studio. Rather, a process of constant learning, refinement, and feedback makes for someone with good production skills. Don't expect to learn the ropes from any article—get into your studio and really use that studio, and think very carefully about what you are doing. Find out what works and what doesn't work. Push yourself some evening just to find out at what point your efficiency drops. Evaluate every piece of music you play; not necessarily while you're playing (you don't want to dilute your concentration) but after your part is frozen on a piece of tape. And don't be too easily satisfied, either; if something sounds funny, or boomy, or grates on you, redo that part. Chances are you can correct whatever problem you have through either a change in attitude or by electronic processing.

See you in Part 2 with techniques for mixdown, assembling, and some thoughts on overdubbing. ~~~~

Copyright © 1977 by Craig Anderton. All rights reserved.

Synapse



Good news from EML
SPECIAL PRICES
 Get more for your money. For a limited time we've reduced our prices on the board.
POLY-BOX
 Now add 26 additional pitch sources and a unique polyphonic capability to your synthesizer. Adapts to most synthesizers.
KITS FOR SYSTEM DESIGNERS
 Do it your way. Design a system that fulfills your own creative requirements. Complete instructions for special applications available.

Write or call today. **NOW CALL TOLL FREE 1-800-243-7270**

EML electronic music laboratories, inc. makers of ElectroComp Synthesizers
 P.O. Box H, Vernon, CT 06066 • (203) 875-0751

REPORT: The International Computer Music Conference.

by Eric Valinsky

The 1977 International Computer Music Conference was held at the University of California, San Diego from Wednesday, Oct. 26 through Sunday, Oct. 30. The conference topics concentrated on the musical end product, and many recorded works and a few live performances were presented during the technical sessions and studio reports. In addition to three formal concerts, reviewed in the Performance section of this issue, an almost continuous exhibition of tape pieces was presented. In all, the participants returned from the conference musically saturated.

The technical session topics were evenly divided between developments in digital hardware: Synthesis Hardware, Real Time Interaction with Computer Music Systems; developments in software: Software for Sound Synthesis, Synthesis Techniques; and developments in perceptual and compositional theory: Compositional Algorithms, Psychoacoustics and Perception.

Studio reports were presented by representatives of a number of computer music installations. On the East coast: Joel Chadabe from S.U.N.Y. at Albany; Barry Vercoe, M.I.T.; Paul Lansky, Princeton; Jon Appleton, Dartmouth; and David Rosenboom, from York University, Toronto. In the Midwest: Donald Byrd, Indiana University; James Beauchamp, John Melby, and Herbert Brün, University of Illinois. On the West coast: about a dozen papers presented from the Center for Computer Research in Music and Acoustics (CCRMA), Stanford; Robert Gross, Jean-Charles François, and Edwin Hawkins from the Center for Music Experiment (CME) at UCSD. In Europe: James Dashow, Rome; Marc Battier and Giuseppe Englert from Groupe Arte et Informatique de Vincennes; Jean-Claude Risset, IRCAM, Paris; Hans Knall, EMS, Stockholm; Pietro Grossi, CNUCE, Pisa.

On the hardware side, a number of digital synthesizers have been or are being built. These include (along with a rough estimate of their cost): the digital hardware being devel-

oped for the Carnegie-Mellon Computer Music System (\$5000); a portable digital synthesizer recently developed at Bell Labs (\$200,000); the Systems Concepts Digital Synthesizer (\$100,000), which is about to be implemented at Stanford; Dartmouth Digital Synthesizer, (marketed by Norlin Music but since discontinued) currently residing at Cal State, Northridge and the New England Digital Corp's "Synclavier"™ Performance Instrument, a portable, computer-controlled keyboard machine (\$13,250).

With the exception of the Bell Labs system and the Synclavier™, which are self-contained, all the above systems require a large computer, such as the DEC PDP-10, to run

them. All of the systems, except for the Bell Labs unit, are designed with some degree of pipe-lining, which is the digital electronics equivalent of pre-patching. In effect, these synthesizers are the equivalent of 16 to 64 Minimoogs controlled and coordinated by computer software.

In contrast, the Bell Labs system is composed of 64 oscillators, 32 digital filters, 32 envelope generators, noise source, and digital delay unit, all independent and patchable in any configuration UNDER SOFTWARE CONTROL. A live performer can interact with the system through an ASCII (digital typewriter) keyboard for programming, and 256 independent manual control inputs, in-



Clockwise from top: Jean-Claude Risset outlined IRCAM's facilities and current activities. Loren Rush (CCRMA) described Stanford's interactive digital recording, editing and processing system. Bruce Rittenbach demonstrating CME's computer music system. John Chowning, Stanford's computer music pioneer, with his wife Ingrid. Many current developments in computer music techniques owe much to Chowning's work.

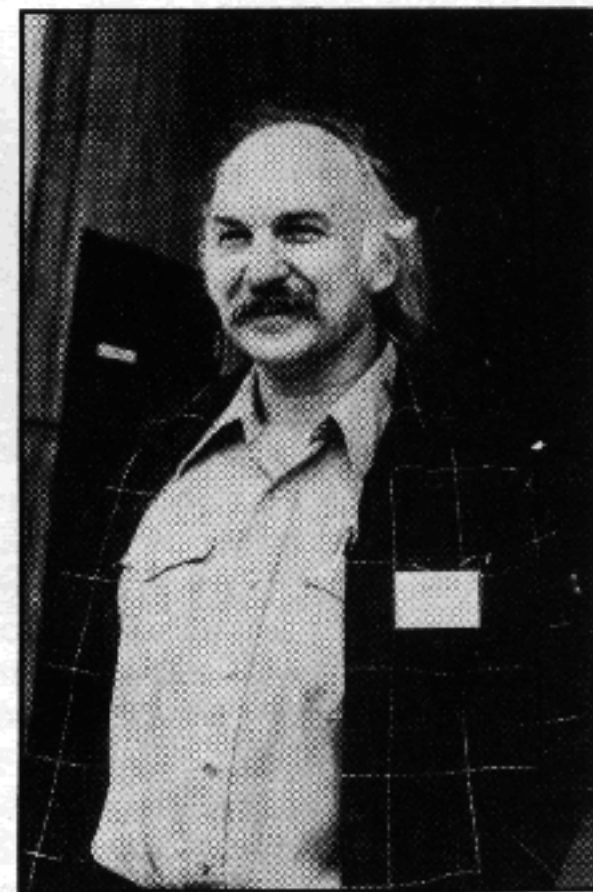

PHOTOGRAPHS BY VIRGINIA QUESADA

cluding two organ keyboards, four three-dimensional joysticks, seventy-two slide pots, and any variety of external control devices. Truly a versatile system.

Equal time must be given to the system designed by Michael Yantis. The presentation lacked elaborate slides, Viewgraphs, or tapes, mainly because the system itself was present. Based on an OSI Challenger micro-computer system, the entire unit is easily carried, set up, and performed upon, and costs less than \$500. In a performance entitled *All One Duet #5*, the system processed signals from two pressure sensitive keyboards played by Yantis and sounds from a live clarinet, and produced some rather raw, dirty sounds. To paraphrase Harry Partch, it did not do very much, but what it did do, it did very well. This was by far the most successful realtime synthesis system presented in that it was the only one on which a complete musical composition was performed in realtime.

On the software side, most computer music studios continue to utilize the should-be obsolete Music 4BF and Music 360 programs for computer music synthesis. In most of the compositions presented, the composer specified a succession of notes, indicating their pitch, waveform, envelope, time of occurrence, and duration, or else the composer supplied an algorithm by which the computer generated a succession of notes, calculating their pitch, waveform, envelope, time of occurrence, and duration. Unsurprisingly, most of the music consisted of a succession of notes, characterized by pitch, waveform, envelope, time of occurrence, and duration.

The program *Sawdust*, by Herbert Brün, is a notable exception. The composer is able to operate directly on waveforms in the following way: the composer specifies a number (which, when converted, becomes an analog voltage level) and a duration for that number (number of samples in which the number is output). He can then Link the numbers to construct waveforms. To compose a piece, the composer directs the computer to *Merge*, to *Mingle*, or to *Vary* the linkages. A fifth command, *Play*, instructs the computer to generate the sounds specified by the composition.

Can beautiful music be produced by this method? The composition presented by Brün, *More Dust*, did not answer this question. It was not beautiful music; it was challenging and exciting music.

To summarize a few trends evident at the conference, first of all, digital computer music is now common and accepted at most universities with large music departments. It is still true that while European governments sponsor electronic music activities, in the United States the activity is mostly limited to the universities.

IBM 360's and 370's continue to be the standard large computers for batch processed (non-interactive) computer music composing, while the Digital Equipment Corporation's PDP-10 has emerged as the leader in interactive musical applications. The LSI-11,

an integrated version of the PDP-11 mini-computer, is becoming the standard for digital control of external synthesis equipment. Now that Heathkit has developed and is selling the H-11, its under \$5,000 (estimate based on a system including a H-11 computer, 16k memory, parallel interface, serial interface, video terminal, paper tape reader and punch and floppy disc.) version of the LSI-11, the future is promising for digital controlled electronic music systems.

In the effort to implement realtime composition, digital oscillators and other external hardware are increasingly being used to eliminate time-consuming calculations and table look-ups. However, the software (i.e. computer programs) has not changed considerably since the development at Bell Labs and at Stanford years ago.

Of the problems that surfaced during the conference, one was trivial and not taken seriously, namely the incompetence in the audio/visual end of the presentations. Slides were upside-down and backwards; tapes were improperly cued. It was amusing that a group of people so well versed in higher technology were unable to cope with the relatively simple technological demands of tape recorders and slide projectors.

The second problem should have been trivial, but was taken seriously. Throughout the conference ran an undercurrent of political activity. It is unclear what was accomplished, and one forms the impression that the political game was played for its own sake. On top of that, the players were not very good at the game, and seemed to derive little recreation from it.

This report will end with some thoughts on a third problem, a non-trivial software problem. A computer system is a general system, and is desirable from the standpoint of flexibility. Unfortunately, composers cannot deal in generalities. A specific product, namely music, must be produced. Therefore, software is developed which limits the generality of the system so that it can be manipulated by composers.

What are the criteria which are used to limit the generality of a system? These depend on the limits of musical imagination of the designer of the software. Responsible for the development of software have been computer programmers, and unfortunately, computer programmers tend to be limited in their musical imagination. This is not to say that they cannot imagine new compositional concepts, but rather that their concepts of musical validity are strictly limited to traditional forms and styles.

Perhaps computer programmers and electrical engineers should not have to worry about musical validity. Let's have their crazy ideas, and let the composers then be concerned with producing musical results from them. This sort of collaboration can eventually result in the development of new compositional methods and, ultimately, of exciting new musical concepts. We look forward to hearing them at the 1978 International Computer Music Conference. ~~~~

EMS VOCODER 2000

for the treatment and modulation of human speech and the production of speech-like effects from music or other sounds. Used by radio, television, studios, groups and theatre.

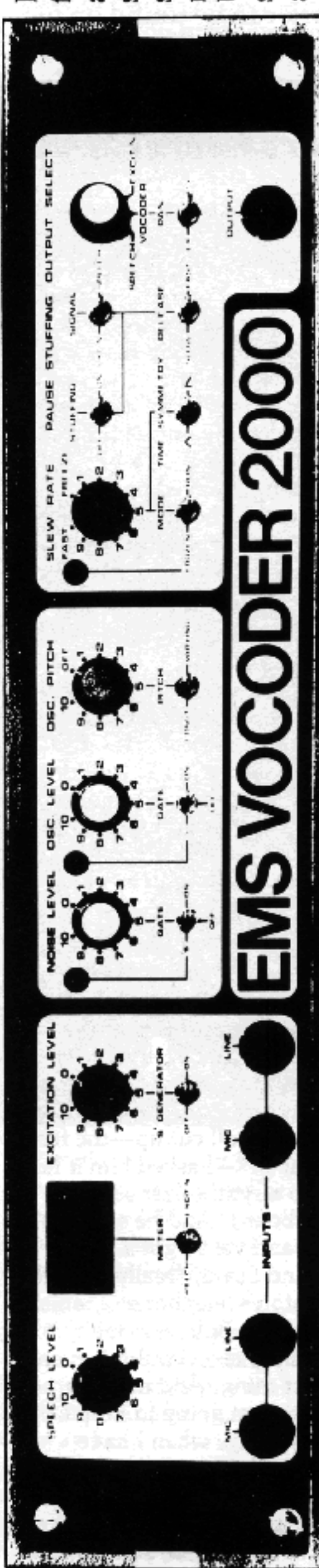

EMS
The Priority
Great Milton
Oxford
08446 - 729

EMS West Germany
7157 Ditzingen 3/Hiemeringen
Finkenstrasse 4
07152 - 53273

EMSA (Electronic Music
Studios of America, Inc.)
269 Locust Street
Northampton
Massachusetts

Piano Center
122 Rue de Paris
Montreuil 93100
Paris

Electronic Music Studio Supplies
5832 Westminister Avenue
Montreal
Quebec H4W 2J8

Zen On Music Co Ltd
25 Higashi Gokencho
Shinjuku-Ku
Tokyo

Timo Laine is one of the earliest users of polyphonic guitar synthesizer technology and has logged more hours of performance with it than any other artist. In this interview he outlines his pilgrimage from straight guitar to mounds of footpedals to the B-300 Guitorgan to his present polyphonic system. Also discussed are the technical demands that a system of this complexity places upon its users. His polyphonic guitar synthesizer work can be found on his A&M disc, *Symphonic Slam*.

by Chris August
& Doug Lynner

Lynner: How did you come into contact with synthesizers?

Laine: I've basically been a guitar player all my life, but I got bored with just playing regular guitar, and when the wah-wah pedal first came out it was like a dream for me. I think that was basically the first step in the arbitration of guitar sound. Then all those little gadgets started coming out, and I bought them all and put them on a big board. Then I gradually hooked up the guitar to those things that horn players use . . . I think they're called arbitrators or something: you know, where you can play saxophone that'll sound pretty freaky. . . .

Synapse: A Maestro?

Laine: A Maestro, that's right. I ran the guitar through that, but the frequency of the guitar was so radical that the unit had trouble figuring out what was going on. It overloaded, it would distort, or it wouldn't work properly. And then the next thing that happened that really got me going into the direction of synthesis was Bob Merrill's invention of the B-300 Guitorgan in Waco Texas.

Chris August: When was that?

Laine: About '74 it came out; I tried some of the prototypes out, told Bob I'd help move that stuff if he'd let me have it. We worked out a deal and I used it, live, for a year, and I bought some Leslies for it. And then I called up Oberheim, and I said, "Hey, I've got this guitar that's all cut up—the frets are all electric contacts."—I asked him if he would hook it up to a synthesizer so it would be like a keyboard. And he said, "It's already been done, and we've got a better way of doing it." And I said, "really?" And he gave me Bob Easton's telephone number. And I called up Bob, saw the machine, and I fell in love—I couldn't even sleep until I had that thing. And now it's not going to stop, it's just going to keep going. Because eventually, when I have twelve synthesizers and the programmer, I'll be able to add six more synthesizers to this, just for special effects. I want to have a Moog for my low E, because on some of the

PHOTOGRAPHS BY BILL MATTHIAS



TIMO LAINE

songs that we're recording for the second album, I could be doing the keyboard player's parts. For instance, I have this one song called "Cyclops," where after the 360 System dies out, there's nothing but pink noise left, sounds like wind—and I have a low frequency oscillator on the low E string making a bubbling sound, like boiling oil. I could be doing the noise, but right now the keyboard player's doing it on a Moog. And now I've got Bob building an interface box for it, where I'll be able to make a multi-pin, y cord so I can hook any part of the synthesizer to any string. You know, I can move on the low E, in addition to the high E, and use a Minikorg, which is cheap, or an Arp Odyssey or 2600.

Synapse: So when will you be getting the programmer installed in your system?

Laine: Before I go on the road. I don't use it in the studio.

Synapse: Do you see any potential for the programmer being right on the guitar itself, on the body?

Laine: I hope not. I don't like anything on the guitar at all. The only thing I really want on the guitar is a volume control.

Synapse: With the expansion of the system to do special effects, will you have the ability to trigger, from your guitar, an effect that would not be related to the string or its pitch?

Laine: I've been experimenting right now, and it's funny you should ask that. There is some difficulty with the trigger; though it seems to be okay for the synthesizer, it is not okay for a digital sequencer. The digital sequencer does not understand the signal. The reason is that when you hit a note on a guitar there's a thud, and then it takes a micro-second or so for the note to identify itself. So what we're doing is trying to put a delay on it to put it just right so that the note will have time to identify to the digital sequencer—then I'll be able to hook up anything to other sequencers.

Synapse: You'll be programming the sequencer and it will tie in with your guitar?

Laine: Yes, that's ultimately it. Ultimately, I want to replace everybody with a machine, so to speak. My whole concept of the expression of music now is the same as when I was studying fine arts, in college: when you have a painting, and you have a vision and a concept of the composition, you don't paint the house or the tree or the ground and then somebody else comes in and paints the clouds and somebody else comes in and paints the people. It becomes less personal. It's great for one person to be able to compose, and play, everything.

Synapse: *So your ultimate goal as a performer is to be able to take care of all the musical parts that before you had to depend on other people for?*

Laine: Yeah, but not so far that it will make the music low quality. I don't think it will be very easy to replace a drummer. I'm really pleased right now with the combination of Jay Medina my drummer using his Syndrums, and regular drums, in conjunction with my system. Just the two of us sound like six, seven, people.

Synapse: *Have you been touring at all recently?*

Laine: I toured Canada. Played with various other acts, Gentle Giant, did a lot of headline concerts around Ontario, Quebec. The company sent me to the United States to do the second album here. I had to become a landed immigrant to do my first album in Canada, because of Trudeau's administration.

Lynner: *You were an American citizen, and you went to Canada to do the album?*

Laine: Yeah, I got turned down by every record company in the United States, so I had no place left to go, and I had to leave the country.

Synapse: *Seems like what a lot of people ought to do.*

Laine: Back here, we got released in 13 countries in just the span of a few months. The record company president told me we don't need the Canadian crutch anymore, because we've got the world. So I'm back home, and I'm happy. Everything's here.

Synapse: *What kind of problems, from a live performance standpoint, are there, using a guitar interfaced with a synthesizer? It's all pretty new, and it would seem there's a lot of room to grow.*

Laine: Well, the first problem I ran into when I bought it was setting it up properly; customizing, special cases, etc. The foot pedals are the only thing that really gave me problems. The pots in the foot pedals were not high quality enough, and I had Bob send me some better pots.

Synapse: *Have you found that you've had to curtail in any way, when playing live, your use of the synthesizer interface compared to what you do in the studio?*

Laine: No, as a matter of fact it's easier to pull it off live, because I hate headphones; you don't get all the frequencies properly. On stage, I've got a couple tons worth of

Cerwin-Vega stuff blasting away at my ears. . . . I can hear every frequency. I can control the synthesizers much easier by hearing them really loud. I can't even get a good sound out of a good studio monitor—and they've got great monitors at A&M Studios and various other studios in L.A. And even when I put my stuff up in the control room, it's still not as good as when I play through my own system. And besides when you're playing live you can stand up, you're bouncing around, and you can get into working your pedals; you can run up to the pedal and press it, and put feeling into your feet.

Synapse: *Are you using any other devices like harmonizers or flangers or . . .*

Laine: I'm using a frequency shifter, on my voice. Vocal synthesis. I use it for raps in between songs, so I can sound like a robot, or I can make my voice sound low. . . . we use it on drums, in the studio . . . I use the Eventide Clockwork phaser on my voice on one song on the album.

Synapse: *Are you interested in people being cognizant that you are using new technology, or are you more concerned about people accepting your music?*

Laine: Well, I've got an awful lot of press in Canada that has put more emphasis on my machines than my music, but it doesn't bother me, because the music is good. The people like the music too, but they've got something to talk about. The interviewers just love to be fed a new thing, and they just talk the hell out of it, too. The machine and the music, together.

Synapse: *Have you been finding that the use of the synthesizer has helped or hindered the success of your music?*

Laine: It's really helped tremendously.

Synapse: *What have you been able to do that you couldn't do before?*

Laine: I've been able to reduce a six-piece band to a two-piece band—it's put a lot more money in my pocket! And I've been able to stir up a lot of interest from the press; I've been able to write more fluently; and I've been able to take different chord concepts on the guitar that normally would sound too jazzy or too classical and put them through my machine and make them sound really cosmic. Before, in writing, I had a keyboard player who had a jillion keyboards in order to get the sound I wanted, and I always wanted to get the sound myself. So I can go into a studio and crank material out much quicker, and have it sound really neat.

Synapse: *You said you could write more fluently: what did you mean by that? Your actual compositional process was more fluent?*

Laine: Yeah, I wrote faster.

Synapse: *But has it changed what you write?*

Laine: Uh-huh. To a certain extent. It's changed my style a little bit—different in the respect that I'm trying to keep more strings

going. It's forcing me, actually, to play more classical. Because you know when you play regular one-line stuff, on a regular straight guitar, you're doing improvisations and you're doing lead blows and stretching notes and making them sing and all that—but with the polyphonic guitar synthesizer, you don't have to. With the new guitar I'll keep two strings doing a completely different thing, and then I'll play lead on top of that with the higher strings, using my third finger as a pick, rather than just using a pick, as normal. In fact for a performance I glue a piece of plastic across the fingernail to use as a pick. So this made me experiment more, to take advantage of the system.

Synapse: *Do you think contemporary*

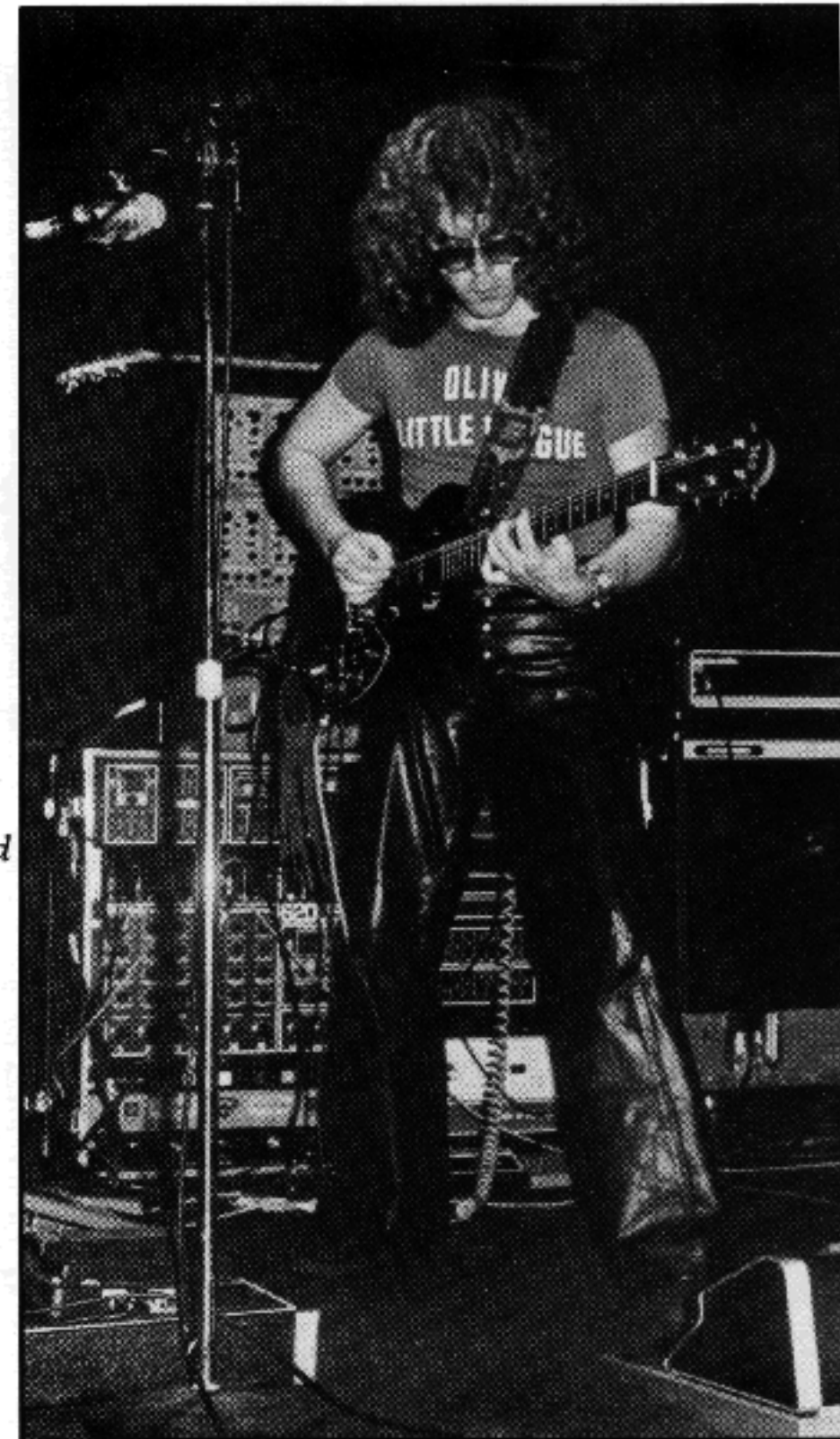

guitar players would be a little bit outclassed by a system of this sort because instead of playing one-line stuff you're playing something that can really utilize all these kinds of voicings?

Laine: Oh, yeah. Any time I let another guitar player use my system, they enjoy the sound they're getting out of it. . . . I know I've seen some that are really frustrated because they can't make it sound the way I can make it sound, because of the way their technique has been developed. I think this kind of system is the perfect mate for a player that is clean: a jazz picker that hits every note just right . . . one thing it

Please turn the page

THE MEDIAMIX JOYSTICK!

If you play keyboard, yet long to play with the musical expression of a guitarist, our JOYSTICK is for you!

With one hand on the keyboard and the other on the Joystick, you can bend or vibrato the pitch as well as timbre, with just the right human touch. Violin, guitar, steel guitar, trumpet, harmonica...these styles and more will be at your fingertips. Each unit is designed for integration into your model synthesizer.

We also make an auto panning device, a superb Ring Modulator, a Triangle Wave Mod (to add that fat sound to your Oberheim), and many other goodies at realistic prices!

Mediamix
4060 Stanford
Dallas, Texas 75225
(214) 368-6846

Write or call for complete information. Send \$2.00 for a stereo demo tape... please specify format desired. THANKS!

Timo Laine's Live Performance System

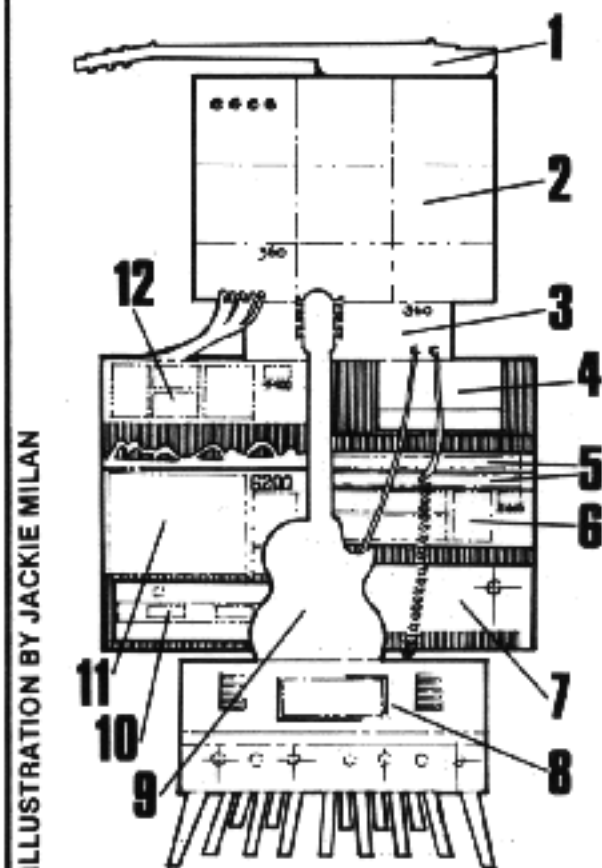
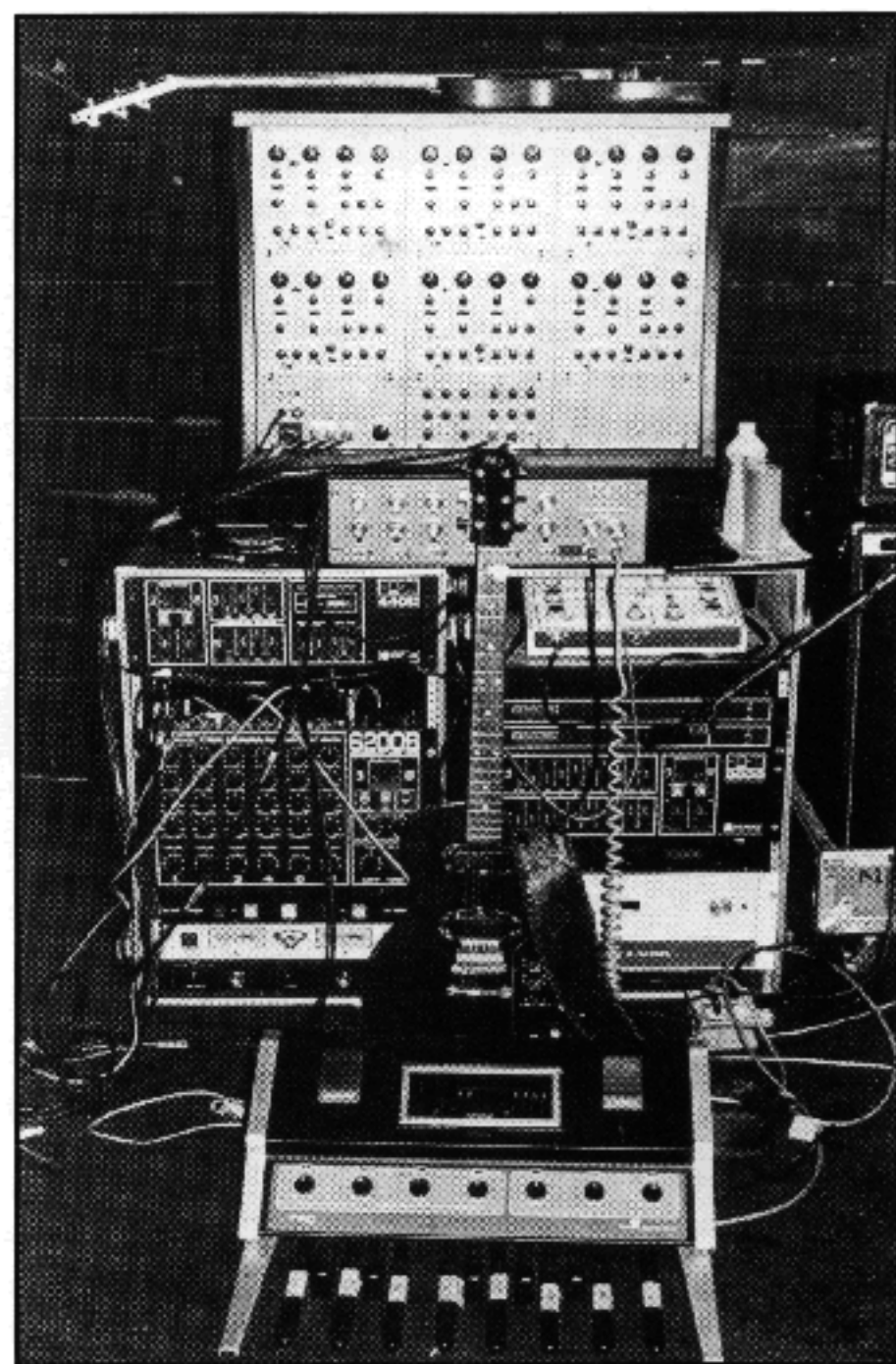

ILLUSTRATION BY JACKIE MILAN



PHOTOGRAPH BY BILL MATTHIAS

... And he says he'd kill for a programmer! Clockwise from top: 1) Rex Bogue/360 guitar; 2) 360/Oberheim Expander Module-based 6 voice synthesizer; 3) 360 pitch to voltage interface; 4) Mutron Bi-Phase; 5) Shure cross-overs; 6) Tapco Two channel graphic e.q.; 7) Crown power amp (for frequencies above 500 Hz); 8) Moog Taurus bass pedal; 9) Rex Bogue/360 guitar; 10) Cerwin Vega power amp (for frequencies below 500 Hz); 11) Tapco six channel mixer; 12) Tapco eq reverb. Timo's pedal board (not shown) includes the following: stereo volume pedal for the guitar synthesizer, a one octave transposer pedal for all six synthesizer voices, a transpose button for fifths or thirds, filter pedal for all six voices, phase switches, preamp distortion switch, Cry Baby wa wa, Talk Box switch, echo on-off, and an envelope switch. The signals from the standard pickups run to a Roland Space Echo then straight into an Acoustic guitar amp.

TIMO LAINE

Continued from page 25

is definitely not for is folk music—you can't do all that garbage-picking where you have all these strings going all at the same time—you have to isolate your strings in sections. You can't just have all your fingers hogging around. It's too much noise.

Synapse: Is it too much for the system or is the sound . . . ?

Laine: It's too much *sound*: your ear doesn't know what's happening. It's overcomplicated, too massive.

Synapse: Do you think that having the synthesizer has cut out a lot of the need for all the foot stuff—this pedal, that pedal . . .

Laine: I have ten foot pedals, and they're all hooked up to the guitar synthesizer. The

only arbitration unit for the guitar itself is the wah-wah pedal and I only use it on one song, that's it. I threw all the other pedals in the garbage can. Literally. I had a whole bunch of them too.

Synapse: Now at this point a lot of bands, even club bands have synthesizers; everybody's got a little Micromoog or something. Do you think guitar synthesizers could become as common as keyboard synthesizers, things like the Slavedriver?

Laine: Yeah, the conglomerate effort of all the companies working together is going to bring it out. It's more likely to happen than not, because everybody wants to go forward. It'll happen slowly, though, because I know the reverb unit took a long time to accept by a lot of pickers, the echo chamber took a long time to accept, the wah-wah was hard to accept, phasing was hard to accept, but gradually it all happens. ~~~

Synapse

State of the art from polyfusion



Meet the Polyfusion 2050 Series, a new line of ultra-reliable synthesizer keyboards. Each of the four new models carries a 5-Year pitch contact warranty in addition to the standard 1-Year warranty on the entire unit. Choose from a wide variety of features including pressure and/or velocity sensitivity, "Micro-Touch" octave transpose, selectable logarithmic/linear glide, one and two voice, and an X-Y Joystick controller.

The **2050 Series Keyboards** are totally compatible with all major synthesizers through use of the optional 2064 Keyboard Interface. The interface contains a regulated power supply and provides all necessary outputs including "S-Trigger" for use with Moog equipment.

With great concern for quality, and employment of the latest "State-of-the-Art" technology, we believe these keyboards are unmatched in the industry. **For complete, illustrated specification sheets and price information write:**

POLYFUSION

160 Sugg Road, Buffalo, New York, 14225

JAN HAMMER

As Jan Hammer moves in a new musical direction with *Melodies*, his recent Epic Records release, *Synapse* thought the time would be right to explore his past, present and future, and considering Hammer's departure from his overt jazz/rock style, there was a lot to talk about. This took the form of questions about the Mahavishnu Orchestra, jazz/rock economics, his escape from the ocean of jazz/rock, his playing as guitar playing, and what synthesizer techniques are important in his playing.

by Doug Lynner

Douglas Lynner: *I listened today to many of the records that you've played on to get a sense of the evolution of your synthesizer playing. It was interesting to see for instance, in the Mahavishnu Orchestra it seemed that you were being utilized still as a piano player.*

Jan: All the time, especially in the beginning.

Synapse: *When were you able to start using the synthesizer as you wanted to? Was it when you were on your own or . . .*

Jan: No, no. It all happened between the first and second album. On the road I would take it into my room and practice to see what I could do. Not necessarily with the sound, because I knew that would take a while and everyday I'm still learning, but as far as the basic playing of the keyboard and utilizing the left hand control (pitch bend wheel) of the Minimoog. To me it hasn't been surpassed yet as far as a versatile all around controller. I spent some time really working out what I could do and it just became really easy and from that point on there was no stopping me.

Synapse: *What was it that attracted you to trying synthesizers in the first place?*

Jan: Expressivity, for sure. There's no way to really bend notes on any other instrument

that I played. I tried with things that came close, like the Oberheim Ring Modulator when it first came out. I had it on the electric piano immediately and it does come close. It takes away though because there's not a definite note. It sort of imitates bending a note but it's more of an effect and I want it to be a lot smoother; to be just like the tone of the instrument that I'm playing. Synthesizer seemed like a natural instrument for that. And I didn't even look at anything else. I just liked Moog's sound. If I had had more money at that point I would probably have gotten a big unit and I wouldn't even have found out about the wheel. Fortunately all I could afford was the Minimoog.

Synapse: *It seemed that on "The First Seven Days" you had found some freedom that you hadn't had before, because the music was so different and also that you decided to play most of it yourself.*

Jan: Well it also connected to the album with Jerry Goodman, where I did all the drums; and the bass lines on keyboards and Jerry did the violins and guitars. But when I did "The First Seven Days" I figured I could produce all kinds of string sounds using not only string synthesizers but also Mellotrons. But it wasn't just freedom, my writing had progressed in the time since the

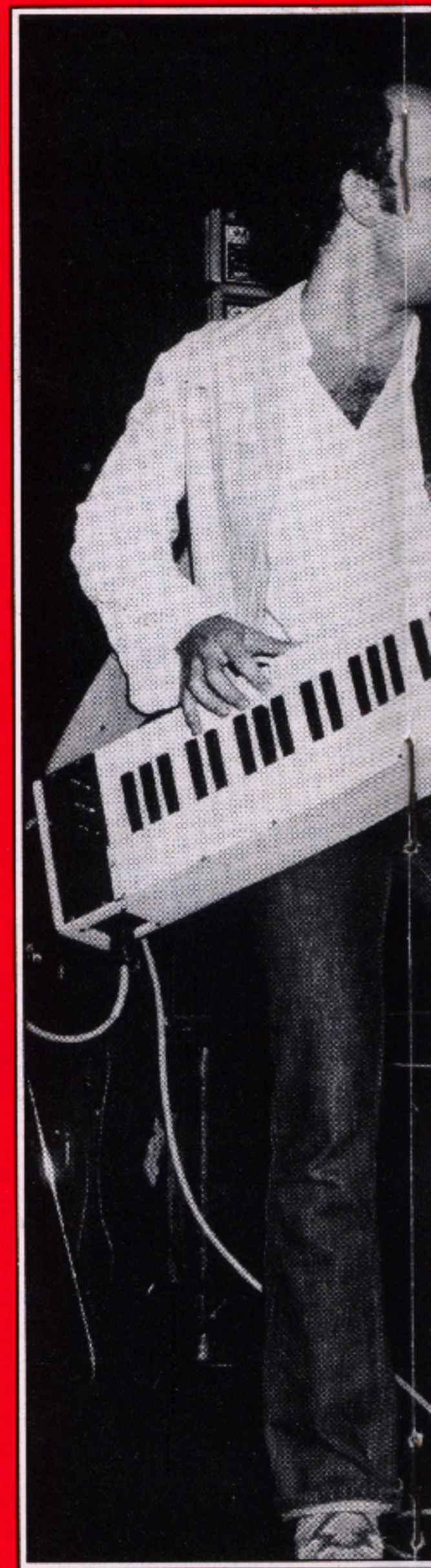

PHOTOGRAPH BY BILL MATTHIAS



Mahavishnu Orchestra broke up. And I moved out of the city shortly thereafter and I began living in the country in upstate New York and just being in the quiet. You know, you hear all that residual noise that's in the city, and when all that ceases you start hearing things that are a lot deeper inside of you and I just could not hear those things living in New York City. My writing has changed radically just from being in a much more introspective mood all the time; being by myself in the country.

Synapse: *Yeah, I can kind of sense that at the opening of the album, there's such a space allowed around the piece.*

Jan: Yeah, and I could do anything I wanted at that point. It's a combination of freedom and also my progress as a composer.

Synapse: *On "Melodies" you've certainly changed what people believe to be your style. Do you feel nervous that some of your old supporters might not understand your change in style?*

Jan: Oh, they will understand it alright. I know they will understand it, but the question is whether they'll accept it. Because a lot of the old supporters come from the real serious jazz or jazz/rock fusion school and those people really take themselves too seriously for my taste; and I got bored with all that and if they don't like it they can listen to those other bands, and I'm not going to be part of it. Whatever I lose I'll gain ten times in other people. I definitely believe that.

Synapse: *I've noticed in recent press material and on the "The First Seven Days" album, that you mention there are no guitars, and there will be none in your band. At the same time, when I listen to your music I get the very strong feeling of a guitar in your playing.*

Jan: Right. That's exactly the point. That's why I had to put the disclaimer on the record.

Synapse: *So that people would understand?*

Jan: Yeah, it's not even for people as it's for reviewers; so they would not confuse people any further—as they have done on the Mahavishnu records and on the one with Jerry Goodman. They assume that it was all guitar but just about half of it was me. So just to set the record straight I had to write that on the record for my peace of mind.

Synapse: *How do you feel about guitars?*

Jan: Well, it's simple. If you listen to music around us, it's about 95% guitar based.

Synapse: *So you feel it's overused?*

Jan: The first requirement to originality, I think, is scratch the guitar. You're half way there; you'll sound original from that point on. I have nothing against guitar, I love guitar, but not in my bands. That's the way I feel about it.

Synapse: *Certainly your playing does fill . . .*

Jan: The void (laughs) . . .

Synapse: *The void—okay.*

Jan: Why should there be a void, right? I mean, why? Who says there's got to be a guitar, but, you know, we're all a victim of it and we assume there has to be a guitar.

Synapse: *And the association is very strong also so I don't think it can be passed by. But I also find a real strong association between your playing and the sitar.*

Jan: Right, true.

Synapse: *I was wondering how much Indian or eastern influence there is in your playing?*

Jan: Years and years of very deep listening, for sure. I've been always very much into Indian music and it's not only Indian music, it's also in Eastern Europe. A lot of the melodies in the folk music incorporate similar tools of expression, like bending notes, slurs and grace notes, that in a way are similar to Indian music. Not in mood or modes, but as far as the instrumental technique.

Synapse: *You've mentioned Eastern European and Indian. Are there other world musics that influence you?*

Jan: Well, I've been playing drums ever since I was a little baby and drums are my big love. I play drums on just about every album at least for part of the album. So far I haven't been able to incorporate it into a stage show because I have my hands full, but a major influence also is African rhythm concepts. Between African and Indian you've got it all covered . . . I guess Latin American, too.

Synapse: *When you say that you have your hands full, that's certainly a technical matter that instrument builders have to consider. What do you need to have designed for your show?*

Jan: Well, right now I'm using a prototype portable keyboard of our own design. It's pretty much put together with Moog hardware but it was built to my specifications by my right-hand man, Andy Topeka, who is just an incredible, very, very sharp guy. He has been with me ever since the Mahavishnu days and he actually built my recording studio where all these records that you mention were recorded; it's all in my house. And he also built this prototype and he's working on a new one which will allow me to play both the Oberheim polyphonic synthesizer and the monophonic synthesizers. Portable, that's where I'm going.

Synapse: *What do you have access to from the box at the left end of the keyboard?*

Jan: At this point it's still fairly simple and quite similar to the Minimoog as far as controls. There's not much more you can do other than maybe bring in switches for a programmable synthesizer which will be on the next version.

Synapse: *Do you feel the instruments you*
Please turn the page



Jan Hammer and violinist extraordinaire Steve Kindler.

PHOTOGRAPH BY BILL MATTHIAS

JAN HAMMER

use dictate in any way what you'll write or play?

Jan: It all depends. There are certain tunes that are definitely influenced by an instrument but mostly, when the inspiration comes, it comes in the least expected moments. You just have to be prepared and that's why you train for long years to capture a complete melody or a whole form and hold on to it before it disappears into the darkness of your subconscious. So you have to either be prepared with a paper or your memory span has to be really long so you can hold the whole form. It's a trip. It takes practice just like an instrument.

Synapse: Often when I interview people I ask them who they feel is responsible for the success of the synthesizer in the commercial market and I always get . . .

Melissa Kojan (Epic Records—Publicity): George Duke quotes Jan Hammer.

Synapse: Yes, it's always one of two people . . .

Jan: Really? You're kidding (looking at the Duke interview).

Synapse: It's either yourself or it's Walter Carlos.

Jan: Wow, great!

Synapse: Herbie Hancock made a similar comment.

Jan: Herbie came up to me in the airport

"Who says there has to be a guitar?"

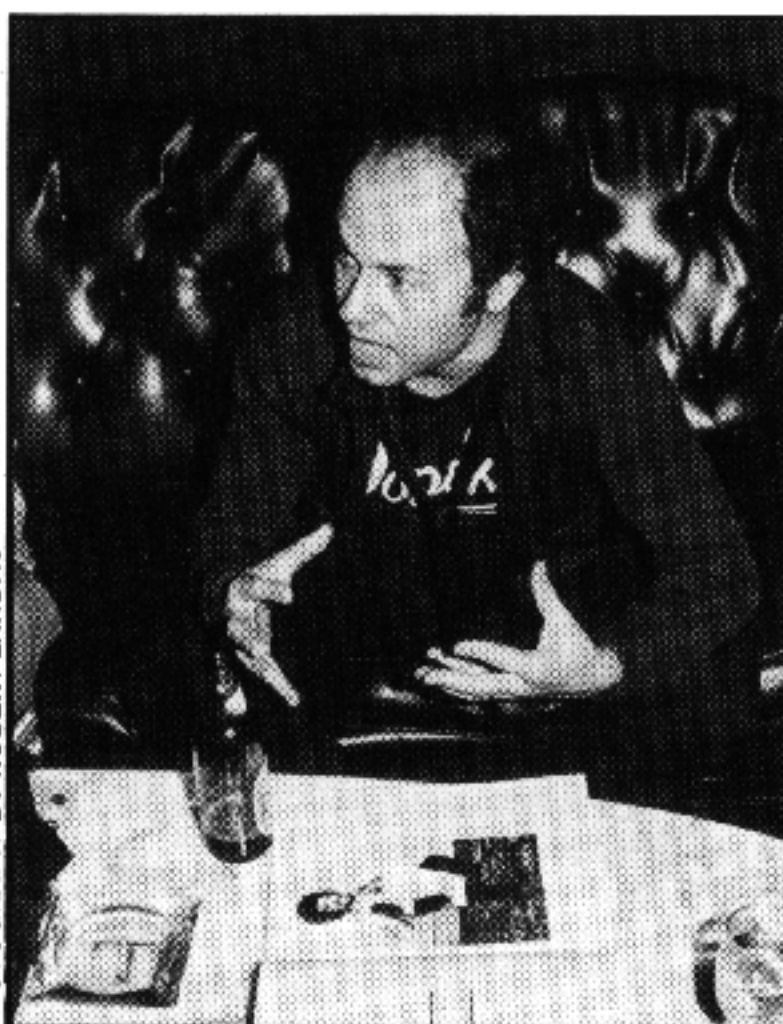

PHOTOGRAPH BY ROBERT LANDAU

in Chicago and said, "When are you going to give me a lesson?" I said (laughing), "Well, it will cost you."

Synapse: How do you feel about that role?

Jan: Well, I sure wish the rest of the industry felt like that (laughs). I've been playing music for musicians for a long time and it shows. I've gotten a lot of respect from fellow musicians over the years. It's great but I think it's time, actually it's overdue and we're doing something about it in the new album, we no longer play for musicians and their friends, for the intellectual underground, you know, the hip crowd. I want to turn on normal people and to me that doesn't mean selling out. It's as much of a challenge to move people as it is to impress musicians. You just use different skills.

Synapse: What is your motivation to approach lots of people as opposed to musicians?

Jan: Joy. I really enjoy a lot of people getting off on what I'm doing. It's a feedback and it really grows with the amount of people, up to a degree, I mean. When there's a stadium it just gets numbing. It's just too many people. But a big crowd is better than a small crowd. Obviously, economic factors come into question as well, when trying to sustain a group of this size. It's just four people but we have about 45 hundred pounds of equipment, and we have a four piece crew that comes with us. So we have eight people on the payroll whether we work or not. We cannot sustain ourselves on playing jazz clubs and that's why the music is also changing.

Synapse: How long have you been on this tour now?

Jan: This is actually the third night; we played San Diego, then here last night and tonight.

Synapse: Do you feel the reaction is what you wanted?

Jan: Yeah—I mean, what more can you wish, right? The reaction was louder than the band. I like that.

Synapse: Is composition of the type on "Melodies" something that you were not able to do before or was it something that you were not interested in doing?

Jan: I was caught up. I was caught up in a circle. Jazz music is pretty much jamming. You know, it can be very advanced but with few exceptions, it will not reach lower than the mental, intellectual level. There are exceptions, of course, I don't want to generalize, but exactly that part of jazz was transplanted into jazz/rock later. It's fun to play that way but it sure isn't fun to listen to. You can be astonished by someone's dexterity and skill but it's not reaching you emotionally. Only a strong melody will do that, or a complete musical statement that includes a strong melody on top of a strong harmony—true composition.

Continued on page 48

Your Instrument of the Future

Technical Research Institute Inc. is committed to the development of a keyboard musical instrument that produces the sound of all acoustic & electronic musical instruments. It uses **Laser-optic memory** discs, does not have tapes to wear & many heads to adjust. It is



ORCHESTRON MODEL X
PHASE FOUR ...

not a souped up combo organ with simulated pre-sets, rather it produces its sounds by **Modulated Light**. It has **Full Polyphonic** capability, every note will play. Laser-optic technology allows the keyboard musician to produce the actual sounds of human vocals, string sections, horns, pipe organs, synthesizers, or any sound that can be recorded. Every



ORCHESTRON MODEL
DOUBLE "D" ...

Orchestron is packaged in the worlds most rugged keyboard case by **Voyager Keyboard Systems** Call now for more information 813-522-2118.



ORCHESTRON
MODEL "D" ...

There's none other like it.
Orchestron
A PRODUCT OF TECHNICAL RESEARCH INSTITUTE INC.

Box 1800, Pinellas Park, Florida 33565

The Most rugged keyboard system...custom built for you!

You have a need for a system that provides function, size, rugged roadability, for your keyboards at a price you can afford. From this need evolved **Voyager Keyboard Systems, Inc.**

The Voyager people provide a custom packaging concept for Keyboard equipment and accessories, pedal systems for Guitarists, special mixing consoles, and discotech turntable systems. Modular construction and wiring allow fast service and repair. Aircraft electronic shock mounting technology gives your equipment the protection necessary for commercial shipping.

Custom etched panels provide you with controls designed with your needs in mind. One power cord and a single output panel reduce the set up time and trouble of several instruments and modifiers to minutes. Your complete system is powered at the touch of a single switch. Our quality standard is high and displayed by the **Voyager Case** in which all your instruments can be repackaged. Ph. 813-522-2118



VOYAGER
KEYBOARD SYSTEMS

Bringing It All Together For You.

Box 1800, Pinellas Park, Florida 33565

by Janet Henshaw
Danielson

Danielson: *What are you working on at the present time?*

Stockhausen: *Sirius*. The last section of *Sirius*, the spring section, must be finished now, and it will be finished in about two weeks.

Danielson: *And it has long sections of electronic sound?*

Stockhausen: It is all electronic.

Danielson: *Uh-huh. What sort of notation are you using?*

Stockhausen: Well, I have transcribed the entire tape as precisely as possible only with respect to timing—everything is precise down to one-tenth of a second in the score of now about two hundred pages, whereas the timbres are not described. The pitches are approximate—sometimes I indicate when the pitch is within the degrees of the chromatic scale, but that's all I can do. It's mainly a score for the musicians who can follow the tape precisely and always know where they are. And then I wrote the four solo parts, in addition to the tape part.

Danielson: *Did you realize the tape here?*

Stockhausen: Yes, in this studio.

Danielson: *Are you still doing a lot of music-plus-drama things like Musik im Bauch?*

Stockhausen: Yes—oh, the last few years are all more or less scenic works—I mean scenic music. For example, *Inori* is for one or two mimes (or dancers) and orchestra. The last performances we always did with two, a man and a woman. They have parts like musicians, as precisely notated as musician's parts. I have also composed a piece, "In the Sky I am Walking . . ." the "Indianerlieder" (*American Indian Songs*), in which all the actions are precisely notated—the dance, and everything else that is happening. Then *Sternklang* is outdoor music in which the runners have an important role. Also, there are certain moments

Karlheinz Stockhausen is world known as one of the earliest and

most prolific explorers in contemporary music. Last issue, Synapse published part one of Janet Henshaw Danielson's in-depth interview, concerning basic influences in both Stockhausen's life and music. In this last installment, he discusses the present, in terms of his own work and the prevailing social/cultural/political climate that is affecting cultural advancement in this day.

Part Two

THE FOR

when the musicians—not only the runners with the torches, but also the sound runners have specific gestures to make. Then the last piece which I composed, *Breathing gives Life*, is for choir, and orchestra. We play the orchestra through loudspeakers if the orchestra cannot be put into the pit; if the performance is not in an opera house, then we do performances on concert stages with the orchestra played over loudspeakers, and the singers have to act all the time. There are twelve soloists from a choir, who have different roles—like someone who's like a magician, someone who's like a star-viewer, et cetera—twelve different roles.

And *Harlekin* is danced in costume, and played at the same time by a clarinet player. It's an extremely virtuoso dancer part, completely notated, forty-three minutes long.

Danielson: *How did you notate the dancer's part?*

Stockhausen: With words and designs. And for *Inori* I have invented a complete new

notation which is very precise. For every twinkle of the eye, everything is notated with musical notes and durations and dynamics and everything.

Danielson: *Do you still work with the group of musicians you've been working with for years—Kontarsky, Bojé—*

Stockhausen: Oh, yes, yes. We just did a series of concerts last month.

Danielson: *You're still doing a lot of concertizing?*

Stockhausen: No, not a lot. I have reduced it extremely, which means I perform perhaps half-a-dozen concerts with Kontarsky, Bojé, Eötvös, Krist and Caskel in a year, and then I conduct perhaps three or four months in a year the works which need my conducting, as long as the scores are not yet printed. So I conduct *Inori*, or *Spiel* for orchestra, or *Trans* for orchestra, or *Punkte* or *Hymnen* a lot—all the scores of which are not yet printed. The moment they are printed then I pass to

something new, so I usually conduct the first ten to twenty performances of each work until everything is controlled and corrected, and then I go on to the next pieces. For example, I now perform mainly *Sirius* with a new group—Suzee Stepheus, Annette Meriweather, Boris Carmeli, my son Markus and two sound technicians—because *Sirius* is a new work, and we have performed it twenty-five times up to now and another half-a-dozen performances are coming up very soon.

Danielson: *Do you think it's important for a composer to work with musicians that he or she has worked with for a long period of time and has a lot of rapport with?*

Stockhausen: Yes, that's important, but not the only thing. For example, now I work with these four musicians. With two of them I've not worked before—the singers in *Sirius*. No, that depends. I also want to enlarge the number of musicians with whom I have worked

Karlheinz Stockhausen: SEARCH CONTROL

extensively so that, one by one, the number of competent musicians becomes larger.

Danielson: *Sternklang* was written, I believe, as a greeting for extra-terrestrial beings. Could you say that you have had contact with extra-terrestrial beings?

Stockhausen: No, I haven't.

Danielson: Back to—

Stockhausen: Just a moment. I should make a comment. When you say with extra-terrestrial beings, you really mean with people—people, I mean—who are recognizable in bodies and who come with flying saucers. Is that what you mean?

Danielson: No, not necessarily.

Stockhausen: Oh, I see. Because usually one thinks extra-terrestrial people. That's what I meant when I wrote the text. I meant it really for people landing here. But besides that, I have naturally had contact all the time with spirits, who do not appear here in the flesh, in bodies. There are two different

things. *Sternklang*, I set *Sternklang* in a more—how can I say—humorous way.

Sternklang is a piece that could very well be the reception music for a team of people from other planets, from other stars who come to visit us. And certainly one day this will happen.

Danielson: Back to the concert, anyway. A lot of composers are dissatisfied with the standard concert situation, and you yourself have done various things to alter this standard concert situation. Could you talk a little about this?

Stockhausen: Yes—the institutions exist, and I think the change that is taking place in the field of music, as in all other fields since 1950, should not only take place outside of the institutions, because that would mean losing all the good musicians who are employed in the orchestras and choirs and as soloists, as they will continue playing there. It would be stupid to simply abandon them because then you would get stuck with

bad musicians. It is necessary that musicians perform a lot, and not only practice, also that they are in competition. So the best musicians, no question about this, are in the field of institutionalized music. But *inside* the institutions every now and then I have tried to arrange different kinds of concerts.

For example, in Bonn, in the Beethovenhalle, I arranged programs in three different halls—programs of four hours each—with chamber music, orchestra music, choir music, soloist music of my own compositions. I had done the timing so well that the intermissions took place at the same time in the different halls so that people could switch from one hall to another. I assumed that there were a lot of people who know certain pieces and have heard them, who would like to listen to other pieces, but that is a special situation for a public that is *really* familiar with my music, which is rare, yet . . . in one city. But it *will* come. I

have proposed a situation like that of Osaka, in the World Fair, which was, as you can imagine,



Stockhausen: "99% of the present-

financed by the German government, as all the other pavilions were financed by the governments of the different countries. There I performed for six months for over a million people, five-and-a-half hours every day, with twenty-one soloists whom I had chosen. Every player would play only every second day, and we had performances between twenty minutes long—each time for about six hundred people—up to one-and-a-half hours long, with one pause in the evening. So we had longer pieces and shorter pieces, but everything was performed live during these six months. And this could be done immediately in any city which is willing to have a Music House, and I have suggested that this Music House should not be too far away from the center, but somewhere on the roof of a big shopping center or something like that—or close to it, so people could just go in for an hour and listen to some music and then go away. But that needs very good management with respect to the engagement of musicians.

Or I have suggested—well, let's not talk about my music for three or four orchestras which takes place in concert halls, or sometimes in halls which are used for dancing because these pieces need flat floors and a square room, if possible, and good acoustics, so you only find this every now and then. But many of my pieces have been performed all over the world in halls which have not been used by orchestras up to now but which are available in these cities. And they are used by the institutions, by the radios or by the city people. They say, "Why shouldn't we go for a Stockhausen concert in another hall?" This has taken place.

But perhaps you meant different situations, like I said before, the World Fair, and then in Bonn. Or in Darmstadt we made *Music For A House*. We had music on three different floors in a house which we rented for one week, rehearsals included, and the public would walk through the house during the performances with a very special set-up, with carpets, and

people behaved very nicely. It was very silent. And in each room you had two, three, four or five musicians, even with a changing number of musicians, for four-and-a-half hours. Everything was made in a way that the people *could* walk without disturbing.

Danielson: *So the audience could create their own music by choosing where to go next?*

Stockhausen: Not create, but choose—I see what you mean, yes—by their movements. Well, at least the acoustical landscape

different rooms. I'm sure this kind of music will come, where the polyphony of the music corresponds with several rooms, several spaces, so you can analyse the piece by walking through the place, you understand that. And in the basement there was a room with four loudspeakers in its four corners where you could hear everything that was happening in the house.

Danielson: *So there was creativity on many different levels, then—not just physical levels, but—*



PHOTOGRAPHS BY BERNARD PERRINE/PARIS

was influenced by the people moving, and the whole thing was composed like a piece that also has polyphony in space, which means the different sound layers would take place in different rooms, and in each room you had loudspeakers, so at certain moments the musicians in one particular room could choose, by opening a potentiometer of another room, to hear what was happening in the other room and even to have dialogues with the musicians in the other room over loudspeakers. That was easily possible. It was a house which allowed individual stratas of sound and made possible connections between the

Stockhausen: Well, I don't know if it's a high degree of creativity—creativity can exist on every level, but it's just multi-spatial. It has more spaces than ordinary music. I mean it's a special case that you have music only in one room, because already when I sit here with you I hear what's happening on the street and there's a soft radio coming from somewhere else. So I am trying to integrate spaces of different kinds more and more, also because every space has a different acoustic and I would like to use that in one piece.

Danielson: *Do you think that music will eventually fulfill the role that the church once filled?*

Stockhausen: What do you mean? The church was the mediator between God and man, and the music is not this, to a large extent. Most, or ninety-nine percent, of the present-day music is materialistic music. It's not religious at all. I'm not talking about music with text—I mean religious music which creates that atmosphere where you feel elevated, where you feel you make contact with the universe.

Danielson: *And this is what you hope for your music to do.*

Stockhausen: I think so. I hope so.

Danielson: *You've said that music today is treated as a commodity or as a toy for people. Don't you think it would be necessary—*

Stockhausen: No, entertainment, maybe. They want to keep people entertained, otherwise they might become dangerous. So music is used now as a means to entertain people, to keep them quiet, to have something that is happening that attracts them, that gets them away from their roles or whatever.

Danielson: *Don't you think it would be necessary to overthrow the current economic system in order to remedy this situation?*

Stockhausen: No, what's necessary is just that this world stops producing so many children, because once it is a fact that we keep the number constant, and that won't happen so soon, then people will rise in consciousness and in demand for cultural food. However, the main demand nowadays is for normal food, like animalistic food. Most of the people are *hungry*, you know that, and have no food and shelter, and the forces of nature are still so violent and so demolishing, so destructive, that most of the human beings have other problems than having the freedom and the inner education—self-education—to enjoy spiritual education. Though what I'm saying seems to be contradictory because in Bali, which is not a very—what can I say—rich society, it is

day music is materialistic music.”

relatively rich, compared to us, because their demands were not for cars and all this. So they are rich, as long as they don't want too much. When they're happy with rice, they can dance and make music. But when they're no longer happy with rice, they can no longer dance and make music, and that's what's happening now. Now they want Japanese cars, and television, so they become unhappy for quite a long while and the music will stop. The evolution of music will stop to a great extent because they will spend less time in making music, and they will spend less time in making instruments and that naturally will lower the level of music and lower the quality of the instruments. So I am giving an example, that you cannot expect that the politicians who are trying to find the votes of the people, are very cultured because they want to keep the people quiet, and in order to keep the people quiet, they are first concerned with the problem of how to find old-age pensions, and all this security business, which means *money*. Money for things other than music. And only if the number of people is constant in the world, can the culture rise on the whole level. You see, Germany is now overflowing with Czechoslovakians and Turkish people, and Hungarians, and as soon as East Germany will be opened and Germany will be reunited we will have a lot of poor people who, again, want television, cars, dresses—all this and that. So the budgets for music will still be cut, and they have already been cut since we have had a socialist government. They were cut half and half again, last year, and this year, again half. So music has no chance, and culture has no chance to develop as long as the politicians need to fulfill the desires of the people who want other things. It's a long process.

Danielson: *Do you think there will be great developments in the technology of music in the next fifty years?*

Stockhausen: Absolutely. What has happened in the last ten years in the field of

construction of synthesizers and additional devices for live performance—even the synthesizer which we have, though it is so imprecise—has improved tremendously our old way of making music. Every day there is a new invention.

Danielson: *Do you think in the future there will be a lot more use of computers, or more hybrid systems where you have a synthesizer and a computer?*

Stockhausen: I don't think the computer will play a very important role.



Danielson: *No?*

Stockhausen: No, absolutely not. Only insofar as the computer can be used to analyse recorded sequences, as I told you before, and quickly use this information for driving filters and generators with this information and transforming other sequences which are played. Let's say a musician plays a melody, and I want the timbre of another musician who plays at the same time to immediately, in real time, be transformed with the melody of the first musician. Then I need a computer, because a computer can analyse the melody of musician number one and drive the timbre of the second

musician with the voltage of that melody. So I always need computers for the intermodulation of different sound sources. There the computer becomes interesting.

Danielson: *So is voltage control going to continue to be very important?*

Stockhausen: Well, I think that is a very good help. If it can be done otherwise, fine. But I don't have any other means. So the best thing is to have a device to instantly store something, and to use that information for modulating something else,

instantly or with any time delay, let's say up to two minutes—two, three minutes—and I don't care how you call it, if it's a computer or a synthesizer or whatever it is.

Danielson: *One last question: do you think electronic music technology helps produce better music?*

Stockhausen: Yes. In the long run, yes, because we cannot go backwards in consciousness, and we are expanding our consciousness of what music can be and how rich music can be at certain moments, or even how relevant dynamics and fine changes of color of sound and the movement of a sound in a given space can be. In order to

achieve this new precision and this new clarity, we need new means. So the well-tempered piano has naturally helped, in the long run, the composition of better music for piano than before that invention, because you simply couldn't compose this brilliant piano music—all the music that is for piano is distinct from a harpsichord or clavicord—music which is unthinkable without the piano. And the orchestra music is unthinkable without the orchestra. So it's like asking if you think that the modern orchestra—or the orchestra altogether—has made better music. Well, yes, because all the orchestral music that has been composed since Beethoven has been composed for the orchestra because the orchestra was there. So it's not that at the beginning of the invention of new instruments you would find the best music, but after a while, the musicians who use these new means will simply compose music which is also, in the long run, better music, because it's more rich, and it enlarges man's consciousness of what music can be. So there is an intimate relationship between the means and the spirit that uses these means, though in the beginning of a new era, this is not quite visible. We think nowadays that music is full of dilettantism, and many people are fooling around with these modern instruments, thinking that is of value already in itself. It's nothing in itself naturally, but it will take a while. And after a while, the musicians, who are forced to make an effort to be precise because they use these instruments and the instruments demand that precision of composition, will, little by little, change their way of composing, and then better music, more complex and with more relationships, so music with more content and also with more profoundness in the psychic sense, more depth—because it is simply more rich, it has more layers—will be composed.

Man's toys will become more and more stimulating and fantastic so that his playing comes always a bit closer to the music of the Divine. ~~~

Time scale is the ratio of the time needed to generate an electronic sound to the actual duration of the sound. For example, if a computer takes twenty-five minutes to generate ten seconds of music, the time scale is 150:1. Similarly, an electronic music composer who works four hours editing a five-minute sequence is operating under a time scale of 48:1. Substantial savings in time and studio cost can be realized by reducing the time scale to its absolute minimum, 1:1. This is known as working in *realtime*.

Most tape techniques, such as overdubbing and editing, are time consuming. In order to achieve a 1:1 time scale, the composer must abandon them in favor of synthesizer programming techniques, including those of analog programming and electrophony covered in past *Synapse* articles.

What are the advantages of working in *realtime*? In the studio, much time and money can be saved in reducing time scale, as was mentioned. More material can be put on a single track, thus reducing the number of channels needed for tape and mixing equipment, and thus reducing equipment cost. If multiple tracks are desired, they can be recorded simultaneously in *realtime*, again saving studio time. Out of the studio, *realtime* techniques enable performances of live electronic music.

There are no disadvantages to the use of *realtime* techniques, only problems. More synthesizer equipment is needed for *realtime* work than for conventional studio methods. On the other hand, synthesizer equipment is cheaper than sophisticated tape equipment.

This article will be concerned with the problems of live electronic music. In order to produce desired electronic sounds live, the synthesist must learn to interface with the synthesizer. Acoustic musicians spend years practicing the techniques of controlling their instruments. Similarly, though in much less time, the techniques of using synthesizer knobs, switches, buttons, foot pedals, and other manual control devices can be perfected. These manual techniques are sufficient to produce electronic music structures of virtually any complexity, given an orchestra of synthesizers and synthesists to play them.

What can a lone synthesist do, with a limited amount of equipment? The flexibility of manual control is limited by the number of hands and feet the performer has. Moreover, it is difficult for one person to follow many different events at once, much less control them. Additional flexibility of patching and repatching is required to increase the variety of electronic sounds available from a limited amount of equipment.

In other words, to permit production of electronic music in *realtime*, with multi-event complexity, and controlled by one synthesist, first, the equipment must be made more flexible, and, second, the synthesist must employ means of automatically controlling the

REAL-TIME

synthesizer, and/or he must interface the synthesizer with the outside world. Means of automatically controlling a synthesizer were covered in past articles. This article will explore means of extending the synthesizer's range and methods of interfacing it with the outside world.

Adding Synthesizer Modules

Extending the range of a conventional analog system is most simply accomplished by expanding the system. Given sufficient duplication of modules, many patches can be available simultaneously and used as needed. The addition of switching matrices and hard-wired connections can simplify the patching situation somewhat.

What if a single patch is used frequently and ties up a large number of modules? For example, a complex filtered drone of four partials requires at least four VCO's and four VCF's. Adding these to an existing system is not cheap. One pays for the stability and trackability of general purpose modules such as VCO's. Besides, standard synthesizer modules may not be best suited to a particular application.

More efficiently, a special purpose module could be added, in this case a drone module. The frequency of a single, inexpensive, manually controlled oscillator could be divided or multiplied inexpensively to produce drone partials. Low-cost VCF's could be used in the module, since exceptional tracking and stability is not needed for this application. Clearly, this is the cheaper solution. Moreover, the module can be pre-patched, eliminating set-up time.

Bear in mind that special purpose modules have limited applications and should not be overused. The sequencer is an example of a special purpose module gone cliché. However, some sequencers have special features which allow them to be used in more interesting applications. A sequencer that provides a separate trigger output for each stage is useful as a master timer, as is described in the author's article, "Analog Programming." A control voltage into a Buchla Series 200 sequencer will determine which stage is on, which means that a finite set of pitches can be generated, but in voltage controlled order, as well as sequentially.

Acoustic Instrument Controllers

The most commonly used manual controller is the analog keyboard, basically a variable resistor adapted to keyboard technique. Other acoustic instrument techniques have been incorporated into controllers such as the Lyricon (a woodwind controller) and

the Universal Valve Instrument (a brass instrument-like controller).

Acoustic and electro-acoustic instruments themselves can be used to control the synthesizer through special interfaces. An interface unit will generally include a "pitch" follower, which produces a control voltage proportional to the instrument's frequency, and an envelope follower, which produces control voltages based on the instrument's amplitude. Trigger pulses and gates are then generated from the envelope follower voltage. In this way, the frequency and the amplitude of the acoustic instrument sounds are preserved and transferred to the synthesizer.

It seems a waste to reduce a naturally rich acoustic or electro-acoustic sound to a boring electronic waveform. Besides, one or more VCO's must be tied up in the process. More attractively, the instrument sounds are input directly into the synthesizer, where they are filtered, resonated, clipped, modulated, given new envelopes, etc. In addition to its timbral advantages, this procedure frees the VCO's for use elsewhere.

In a like manner, pre-recorded concrete sounds can be used to control the synthesizer automatically. An envelope follower processes the sounds to produce control voltages and non-periodic timing signals. In addition, the concrete imagery enriches the electronic sounds.

Interfacing With The Outside World

This section explores methods of interfacing a synthesizer with the outside world: with performers such as dancers or actors, with films, with the audience, and with the ambient environment of the performance area.

The position of actors and dancers in a performance space can be monitored in a number of ways. Capacitance plates and other proximity sensors measure the closeness of a performer to a particular fixed area. (The closer the performer to the sensor, the higher the voltage produced.) An electric eye responds when a performer passes through a certain point, breaking its beam. Arranged in a grid pattern and decoded by the appropriate interface, electric eyes can be used to pinpoint the position of the performers in space. Microwave fields are sensitive to the presence and the speed of movement. The sounds of the performers can, naturally, be picked up by microphones.

Theoretically, dancers can be wired directly into the interface system, a proposition generally viewed with hostility in the dance world. Mercury switches, attached to a dancer's costume, will turn on when the dancer's body is in certain positions. In this way, gates and triggers can be produced. The gal-

ELECTRONIC MUSIC

vanic responses of the dancers can be monitored through electrodes, if the dancers consent to having electrodes glued to their skin. To disencumber dancers from long wires, the information from the switches and electrodes can be transmitted through radio waves.

The problem of recording high fidelity sound on film can be circumvented by using a live electronic music soundtrack. Pulses can be recorded on the film's soundtrack and used to control the synthesizer, thus synchronizing the sounds with the film. Photocells (light sensors) are basically light controlled pots and can be used to produce a control voltage output. Mounted on the screen, they can cause a synthesizer to respond to the position and intensity of the visual image.

Photocells have performance uses also. Performers, aiming flashlights at photocells, can control sound event parameters in a dramatic way.

Many of the above techniques can be used to monitor the audience: their movements (electric eyes, microwaves), their proximity (capacitance plates), their sounds (microphones). Of course, if the audience is seated and quiet, the results obtained will be uninteresting. At this point, members of the audience may attempt to walk out, where they can be intercepted by electric eyes, microphones, etc. In many of these situations, the audience learns to control the sound consciously, and thus becomes the performers.

Various parameters of the environment can also be monitored. Photocells can be used to measure ambient light. Thermistors (temperature controlled resistors) measure changes in the environmental temperature. Also usable are: traffic flow meters, switches on doors, windows and seats, barometers for air pressure, anemometers for wind speed, seismographs for earth movements, and much more. Probably anything can be monitored.

How are the signals from the above measuring devices interfaced with an electronic music system? Some of the devices generate control voltages directly proportional to the amount of the parameter they are measuring, for example photocells, proximity sensors, and temperature sensors (thermistors). These voltages require simple additional circuitry to be compatible with synthesizer control voltage inputs. Other devices directly provide pulses (electrodes, electric eyes) or gates (switches), which are then conditioned by additional circuitry to provide synthesizer compatible timing signals. Microphone signals can be used directly or processed as acoustic instrument sounds are above.

Timing signals can be produced from control voltage outputs by comparator circuits. A positive voltage comparator outputs a gate signal when the control voltage rises above

a given threshold level. Negative voltage comparators respond to voltages below the threshold. A window comparator produces an appropriate gate signal when the control voltage falls within a specified range. By connecting window comparators end to end, the full voltage control range from a device is divided into segments. Each segment will produce a separate gate signal when the control voltage level falls within that segment. If the output from each segment is routed to the input of a different event, one sensing device can effectively control the timing of a number of events.

Digital Techniques

The application of digital circuitry is perhaps the most important contemporary development in electronic music. This section will show merely how digital circuitry can enhance the techniques of the preceding sections.

Digital circuitry can be used in special purpose modules. The digital sequencer, for example, is functionally similar to its analog counterpart. It has a greater capacity to store voltage levels, but still must be set up manually, and lacks the triggering flexibility of the analogs.

A step in complexity above the digital sequencer is the intelligent keyboard, which accurately repeats a sequence of notes that is played on it. Another special purpose module, the digital polyphonic keyboard, has unfortunately fallen prey to overuse.

A microcomputer can be effective in controlling an automatic patching system. Selected outputs and inputs of synthesizer modules are routed through a matrix of electronically controlled switches (CMOS analog switches, for example). Connections between modules are made when a gate signal from the computer turns on the appropriate switch, or switches. Entire patch configurations can be stored in computer memory, tape, or disk and recalled (connected) at will.

The initial settings of the synthesizer modules are as important to a patch as the actual interconnections between the modules. In a hybrid (computer controlled analog) system, for example the Buchla Series 500 system, the computer furnishes offset voltages to the modules in addition to patching them together. A large computer system can also generate voltage sequences and functions, which can eliminate sequencers, sample and holds, and other control voltage sources.

A microcomputer can coordinate signals from the outside world, generated as in the preceding section. Suppose every time a performer or audience member came near a capacitance plate, Event A was heard. Or suppose that every time a dancer raised his or her hand, a sound was heard. These types of

one-to-one control are easily learned by the performers, but soon become obvious and boring.

On the other hand, suppose that the proximity of a person to the sensor would randomly either cause or not cause some randomly determined event to occur. This situation, though more interesting, is uncontrollable.

What is needed is an algorithm for interfacing the control signals from the sensors with the synthesizer that is fairly predictable, but not one-to-one. The gate output from each sensor appears at the microcomputer inputs. Using the algorithm, the microprocessor makes decisions and outputs control signals to the synthesizer based on which gates are on or off, or else which gates *have been* on or off in the recent past.

Many possible algorithms can be programmed into the computer. For example, a gate signal from Sensor 1 causes Event A to occur, but only when the gate from Sensor 2 is on. Or, the control voltage from Sensor 1 controls Event A if there has been a previous gate from Sensor 2. If not, the control voltage from Sensor 1 controls event B.

What does the future have in store? As the price of digital technology comes down, microcomputer systems become more and more sophisticated. Moreover, their power can be amplified by using more than one microcomputer in a master-slave configuration or in parallel. Eventually, a low cost computer system will be powerful enough to perform direct digital synthesis. Rather than control analog equipment, the computer outputs will be directly converted into sounds.

With sufficient memory, an entire musical composition could be generated at the push of a button, or at most the typing of a few keys. The composer will be required to learn digital programming techniques. Analog programming techniques will become obsolete. The techniques of this article will become obsolete. In fact, analog synthesizers themselves will become obsolete. Conventional manual control techniques are already obsolete, but they will become even more so. Performance practice in general will become obsolete. Since a computer is not particularly interesting to watch, maybe audiences will become obsolete.

This is getting increasingly far-fetched. But, seriously, techniques of digital synthesis should be interesting from a performer standpoint. If not, the music produced is about as interesting to experience as tape music, but without the excitement of watching the reels go round and round on the tape machine. Although the techniques of analog control presented in this article lack the sophistication of direct digital synthesis methods, they are nevertheless exciting to perform and to observe. ~~~

THE BEAT GOES ON

In part one, the author discussed the basic behavior of sound waves and their interaction. Part two explores combination tones and the effect of temperament on combination tones. For instance, will the combination tone produced by the notes D# and E (with the same tonic frequency) be the same in both the natural and tempered harmonic series? Read on and find out.

by Jon Dattorro

When two or more tones of sufficient presence relative to each other occupy the same space and have slightly different frequencies, the phenomenon known as *Beats* will occur.

The addition of waveforms A and B in Figure 4, results in the new waveform C. It can be seen that C modulates from an amplitude which is greater than A or B to that which is less than A or B. We may conclude that *Beating* is a form of amplitude modulation (AM). The frequency of the AM heard in the interference pattern will be equal to the difference between the original waveforms. The perceived pitch will be the average frequency of the same waveforms.

A phenomenon related to beats is the occurrence of *Combination Tones* which are produced whenever any two or more tones of audio or ultra-sonic frequencies are simultaneously present. They can actually be heard as tones which equal the difference and summation of the pitch-frequencies involved and again are a function of the interference pattern produced by the simultaneity. Thus, *Combination Tones* also come about as the result of a form of *Amplitude Modulation* which takes place at audio frequencies, and their spectra will be related proportionately to the tones which produce them. To reiterate: the pattern of interference created by a group of waveforms will repeat itself at a rate equal to the sums and differences of the frequencies involved simultaneously!

Now we are able to understand that the definition of a "repetitive waveform" need not limit itself to a description of such simple modes of vibration as the sine wave, but may even describe the repetition of an intricate pattern within which each cycle of repetition, while internally evolving, creates a spectrum possessing sub-components (combination tones) not present in any of the original component waveforms, and which pattern will therefore vibrate in whole (the interference pattern itself) and in parts (sub-components & components).

The point at which beats turn into combination tones is as much in dispute as whether they are related phenomena at all. In any case, that approximate point of metamor-

phosis depends upon the perceiver and his own conception of the two.

A major discrepancy between the two phenomena of beats and combination tones is that in the case of the latter, the overall pitch perceived will not be the average of the pitch-frequencies involved, but will be both (or all) of the pitch-frequencies and their sum and difference tones. In many cases the difference tones are easier to hear due to the effects of masking especially on tones which lie relatively higher in pitch. The individual amplitude of the combination tones will be proportionately much less than their progenitors, but under some conditions combination tones may become musically vital or obtrusive depending upon the composer's intent.

A superb acoustic example of combination tones used as a compositional device is to be

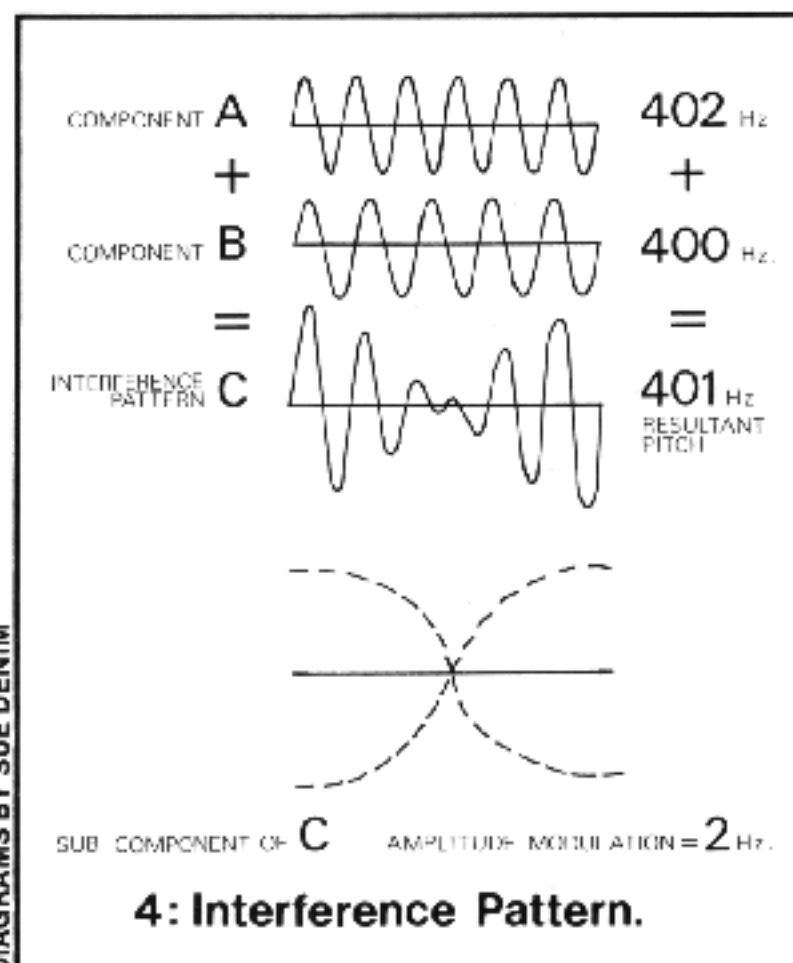

found within the manuscript of Gyorgy Ligeti's "Atmospheres." (If you have seen Stanley Kubrick's film *2001*, you may have heard it there.) Towards the ending of this work (bars 85 through 87), several flutes play closely together in their uppermost register creating low frequency difference tones which seem to buzz like bees.

Electronically generated combination tones are much easier to produce and hear than are the combination tones produced by acoustic instruments because the comparably more intense raw electronic waveforms are much more steady-state and the frequencies not as variable. All that is required are two oscillators which are then heterodyned by a mixer (simply pass two or more audio signals through any mixer then out). If a VCA is used instead of a mixer, the Amplitude Modulation aspect of the phenomenon is enhanced due to the electronically increased depth of modulation, and the relative loudness of the sidebands becomes greater (Pass

one audio frequency oscillator through the signal input of a VCA and the other through the control input).

The vibrations produced by most strings fall into the category of the aforementioned intricate "repetitive waveform" since they tend to vibrate in whole and integral parts simultaneously, the integral parts producing frequencies which are successively higher multiples of the fundamental frequency. These multiples can be graphed musically as the *Natural Harmonic Series* (Fig.5).

The *Natural Harmonic Series* is made up of pitch components whose individual amplitude coefficients by definition do not exceed the amplitude of the resultant total interference pattern, and whose waveforms are sine, the simplest of waveforms. By examining the accompanying table of frequencies (Fig.5) for the natural series only, it will be noticed that the difference in frequencies between any two adjacent component-harmonics will always be equal to the frequency of the fundamental (low A). This has the effect of tremendously reinforcing the fundamental pitch since the combination tone produced by each adjacent harmonic will be part of an interference pattern whose mode of repetition will be preponderant upon a frequency of 110 Hz.

For example, suppose we were to filter out just the third harmonic of the series (E at 330 Hz), it would still effectively be present and audible due to the combination tones produced by the frequency differences of harmonics: 1 & 4, 2 & 5, 4 & 7, etc.

If we were to perform the same experiment on the lowest C of a piano, this time just filtering out the lowest component harmonic (C), we would hear no audible change in timbre or pitch since the piano is one of those special cases where the fundamental frequency does not necessarily determine the frequency of the perceived pitch. This is due to the stiffness of the piano's steel-wire strings. Many of the perceived pitch-frequencies differ from the fundamental frequencies as the result of progressively deviated harmonic series. Those piano strings' harmonic series therefore produce interference patterns whose preponderant modes of vibration are either sharp or flat in their frequencies, relative to the fundamental. The consequence of this idiosyncrasy of the piano is that the fundamental of each affected string must be tuned sharp in higher registers and flat in the lower to compensate for the aberrated combination tones. Although this peculiarity seems to complicate matters, it does not prohibit an experienced tuner from making the piano conform to its equally tempered system of tuning.

The previous filtering experiment is performed every day when we listen to a concert pianist or symphony orchestra broadcast over a transistorized pocket radio. Were it not for our ability to perceive this natural phenomenon of the *Interference Pattern*, the 300 Hz or so lower frequency response limit of the tiny speaker inside the radio would prevent us from discerning the pitches of all

ASSUMING A=440 Hz



5a: Natural Harmonic Series.

	Natural		Tempered
1/1	or 1.0	unison	1.0 or $(\sqrt[12]{2})^0$
12/11	or 1.09091	minor second	1.05946 or $(\sqrt[12]{2})^1$
8/7	or 1.14286	major second	1.12246 or $(\sqrt[12]{2})^2$
6/5	or 1.20	minor third	1.18921 or $(\sqrt[12]{2})^3$
5/4	or 1.250	major third	1.25992 or $(\sqrt[12]{2})^4$
4/3	or 1.33333	perfect fourth	1.33484 or $(\sqrt[12]{2})^5$
7/5	or 1.40	tritone	1.41421 or $(\sqrt[12]{2})^6$
3/2	or 1.50	perfect fifth	1.49831 or $(\sqrt[12]{2})^7$
8/5	or 1.60	minor sixth	1.58740 or $(\sqrt[12]{2})^8$
5/3	or 1.66667	major sixth	1.68179 or $(\sqrt[12]{2})^9$
7/4	or 1.750	minor seventh	1.78180 or $(\sqrt[12]{2})^{10}$
11/6	or 1.83333	major seventh	1.88775 or $(\sqrt[12]{2})^{11}$
2/1	or 2.0	octave	2.0 or $(\sqrt[12]{2})^{12}$

5b: Natural vs. Tempered Harmonic Series.

the tones played below that limit, probably resulting in a pandemonium of unintelligible sounds. The same of course holds true for the upper range.

The *Natural Harmonic Series* is produced of its own accord whenever capable vibrating bodies are set into harmonic motion by external forces. This means that we can directly hear its effects in musical instruments as a function of subjective impressions: that is, when an instrument sounds bright or brassy, we know that many harmonics may be present; conversely, dull or mellow sounds usually possess fewer or lower component harmonics and may sound less loud.

Returning to the graph of the harmonic series (Fig. 5), it can be observed that the numbers denoting the location of each harmonic within the series also tell us something about the intervallic relationship the corresponding pitch has to the fundamental and more so, its neighbors. For example, if we multiply the frequency of the fundamental (110 Hz) by (location) 8, we get 880 Hz which corresponds to the eighth harmonic. But, what is more interesting, if we form a fraction of two location numbers by using the higher location number as the numerator and the lower as the denominator (e.g., 4/3), and multiply that fraction by the frequency represented by the denominator (330 Hz), we get the frequency of the pitch represented by the numerator (440 Hz).

With this new knowledge we can therefore determine the intervallic relationship of any two harmonic frequencies: e.g., given frequencies 1870 Hz & 1320 Hz, we divide 1870 by 1320 which equal 1.4167 or 17/12. The intervallic relationship of the 17th harmonic to the 12th harmonic is the tri-tone. Extending this logic, we should then be able to construct natural scales and chords using interval ratios found within the *Natural Harmonic Series*; but here a problem crystallizes.

To illustrate: suppose we wish to construct an augmented triad (A-C#-E#) using an interval ratio for the Major 3rd within the *Har-*

monic Series (5/4). Multiplying 440 Hz (A) by 5/4 we get 550 Hz which corresponds perfectly to the frequency of C# in the *Harmonic Series* using A at 110 Hz as the fundamental. We proceed again using the same process to find the frequency whose pitch lies a Major 3rd above our C#, and we get (550 Hz x 5/4 =) 687.5 Hz which frequency corresponds to the pitch of our desired E#. We have thus constructed a natural augmented triad . . . or have we?

If we should choose to determine the frequency of the pitch which lies a natural Major 3rd above the E# we just calculated, we can use the same formula thereby insuring that the Major 3rd interval between A, C#, E#, and the new pitch, remains the same. So, proceeding from E# at 687.5 Hz, we multiply by 5/4 and get 859.4 Hz which corresponds to G-double-sharp, or rather, A-natural. But we already know the frequency of A-natural to be instead 880 Hz (not 859.4 Hz) an octave above A at 440 Hz. From this we learn that in Nature, three Major 3rds do not add up to an octave.

The moral is that all natural intervals are not created equally. Rather, the creation of equal musical intervals is a concept of *Man* superimposed upon *Nature* who does not allow equal parts to exist within its boundaries.

Many sizes of the same interval-class can be found among the ratios of the *Harmonic Series*. For example, in Figure 5, the several intervals of the Major 3rd formed by the ratios of location numbers: 5/4, 9/7, 11/9, & 17/13, have a standard deviation of 21 Hz from their average frequency span when figured with A at 440 Hz as their root. In comparison, there is always only one ratio for the interval of the Major 3rd in the Tempered system.

Only in *Man's* musical convention will the "Circle of Fifths" lead back to the beginning. *Nature's* is not a "circle" at all, but is a spiral helix.

Although there exist a limitless number of

itches, *Man* (in his orderly way) called A "440" and decided to divide the octave (represented by a 2 to 1 ratio in nature) into twelve equal musical parts (now called semitones) and limit the number of available musical pitches by delineating those pitch-frequencies to be used. Variance within this convention would be called "nuance." So, using his knowledge of mathematics, *Man* invented the system of *Equal Temperament* according to which forever after no interval—except the octave—would remain pure.

Since the octave ratio is 2, then the interval ratio of each semitone is figured by successive powers of the twelfth root of two. (Equal Temperament interval ratios = the 12th root of 2 to the N; or, 1.05946 to the Nth power: where N = the chromatic location number of the semitone [0 to 11])

Using the table in Figure 6, derivations for the frequencies of the tempered pitches in Figure 5 come to light. To find the frequency of the tempered C# above A at 440 Hz, for example, one need just multiply 440 Hz by the 12th root of 2 to the 4th power (1.25992) to get the Major 3rd at 554.4 Hz. (C# is the 4th semitone up from A, so N = 4) If we perform the augmented triad experiment in the Tempered system, we will find the exact octave above the root to be the result. As proof, we can proceed from our C# at 554.4 Hz and multiply by the 12th root of 2 (1.05946) to the 4th (1.25992) which equals (E# at) 698.5 Hz, then, x 12th root of 2 to the 4th = (A at) 880 Hz! In the Tempered system, three Major 3rds always add up to an octave.

Since there exists no "tempered natural harmonic series," the frequencies of the tempered pitches most closely corresponding to those of the *Harmonic Series* were just given in order to be able to compare the differences in frequency between naturally derived pitches and their counterparts in the equally tempered system (Fig. 5).

continued on page 40

NATURAL Hz	TEMPERED Hz
20C#	2200
19C	2090
18B	1980
17A#	1870
16A	1760
15G#	1650
14G	1540
13F#	1430
12E	1320
11D#	1210
10C#	1100
9B	990
8A	880
7G	770
6E	660
5C#	550
4A	440
3E	330
2A	220
1A	110
20C#	2217.5
19C	2093.0
18B	1975.5
17A#	1864.7
16A*	1760.0
15G#	1661.2
14G	1568.0
13F#	1480.0
12E	1318.5
11D#	1244.5
10C#	1108.7
9B	987.8
8A*	880.0
7G	784.0
6E	659.3
5C#	554.4
4A*	440.0
3E	329.6
2A*	220.0
1A*	110.0

**There may be more than 20 harmonics in a series. *Only the octave relationship remains pure in the tempered system.

6: Interval Ratios.

BEAT...

continued from page 39

Thus far, it has been shown that tones sounded simultaneously produce combination tones. It has also been shown that the components of the Natural Harmonic Series produce very specific difference tones. But we have not examined the combination tones produced by pitches in the Tempered system. We have seen that those difference tones produced by the Harmonic series are *already* components of the series from which they were derived. (The same holds true for the summation tones.)

To reiterate: the difference tone produced by Natural series A \sharp at 1870 Hz, (Fig. 5) and B-natural at 1980 Hz, is the fundamental component of the Series, A-natural at 110 Hz. (1980 - 1870 = 110) However, the same two corresponding components of the Tempered system do not yield a similar result.

The frequencies of the tempered A \sharp and B-natural above A at 1760 Hz are exactly 1864.6550 Hz and 1975.5332 Hz respectively. The difference tone produced by these two pitches is a tone whose pitch-frequency is exactly 110.8781 Hz. This new tone is very close to the tempered A at 110 Hz, but no cigar! As a matter of fact, none of the combination tones produced by the tempered

system will yield a pitch-frequency that already exists as a component of the system (except those produced by octaves and unisons). This means that whenever tempered pitches are sounded together, the resultant combination tones are going to be either sharp or flat, or rather, just plain "out-of-tune" relative to the interval of the progenitors. (e.g., tempered C \sharp at 554.4 Hz and A at 880.0 Hz yield a difference tone at 325.6 Hz which is close to E at 329.6 Hz of the Tempered system, but off by an amount of 4.0 Hz)

These discrepancies within the Tempered system do not detract very much from the beauty of a well tuned piano, however, because a piano is made to resonate well at all frequencies up to approximately 5000 Hz. So, when the dampers are up, the out-of-tune combination tones will be strong enough to make the correct strings, whose pitches lie closest to them, sympathetically vibrate thus causing a "forced harmonic reinforcement".

"Out-of-tune" combination tones will be very audible in the electronic medium though, because there are no convenient broad-bandwidth resonances to cover them up. Take for example, automatic electronic frequency dividers, which are most always found to produce intervals whose ratios are derived from the Tempered system. The quickest way to determine the truth of this statement is to program one to produce an interval such as a "perfect" 4th at a comfortable loudness level. Beating of coincident harmonics, whose rate depends upon which

octave the interval is in, should be very prominent (making the interval in reality an imperfect 4th) and in this case, a difference tone two octaves below the upper pitch should quite easily be heard to be sharp! Automatic frequency dividers are calibrated this way in order to adhere to past convention. What seems to be taken for granted is the flexibility of existing electronic music instruments which makes it possible to simultaneously incorporate natural tuning (given an adequate control system) and/or any other tuning system the user wishes to work within. Indeed, one does not need to use a tuning system at all. If the Beat phenomenon is found to be a pleasant side-effect of the Tempered system, then what is to prevent the artistic use of beats within natural intonation?

The piano and violin are only two of many acoustic instruments which rely upon the natural phenomenon of the Harmonic Series to structure their timbres. Even unprocessed electronically generated waveforms (such as the sawtooth) imitate the Harmonic Series' internal structure. All those intervals found within the first twenty or thirty harmonics of the Natural Series, however, are still only a few of an infinite possibility. The artist does not *need* his intervals to produce combination tones that are integrally related. Many great artists have found the Tempered system to be quite suitable to their needs.

The Tempered system of intonation was an ingenious invention which, since the advent of the synthesizer, need no longer reign. Its interval ratios are not only very close to those of the Natural Series, but the Tempered system also facilitates tonal modulation without loss of the original tonic pitch-frequency.

Although the natural intervallic ratios may seem to be more consonant due to their relative absence of Beats, the choice of intervals to use is as limitless as the number of audible pitches, and the voltage-controlled synthesizer can be most agreeable to facilitating choices. If an artist should choose to employ the use of a conventional keyboard controller, it need not be fixed to the Tempered tuning system and neither must a frequency divider offer only twelve intervals from a countless variety. But, the option to choose the Tempered system must remain since the universality of the synthesizer implies an absence of prejudice to one system over another.

Perhaps when the full potential of the synthesizer is realized, giving enough individuals a glimpse of the future, then maybe manufacturers will be forced out of a new necessity and demand to produce instruments which are more universal in their applications. Sound is not only the "metier" of a musician but is Man's primary form of communication as well. There is no reason why all people should therefore not be able to take advantage of a new sound-source. Given an adequate interface (control system), many ingenious new applications of the synthesizer will most definitely be found; hopefully, some will be in the realm of music. ~~~~

Synapse

**ELECTRONIC MUSIC:
IN-HOUSE PRODUCTION
SCORING/ARRANGING
RECORDING • RENTAL
SALES • CONSULTATION
INSTRUCTION • 2825
HYANS ST. LOS ANGELES
90026 • (213) 487-5148**

Sound Arts

String Synthesizers Can Be: Just strings...

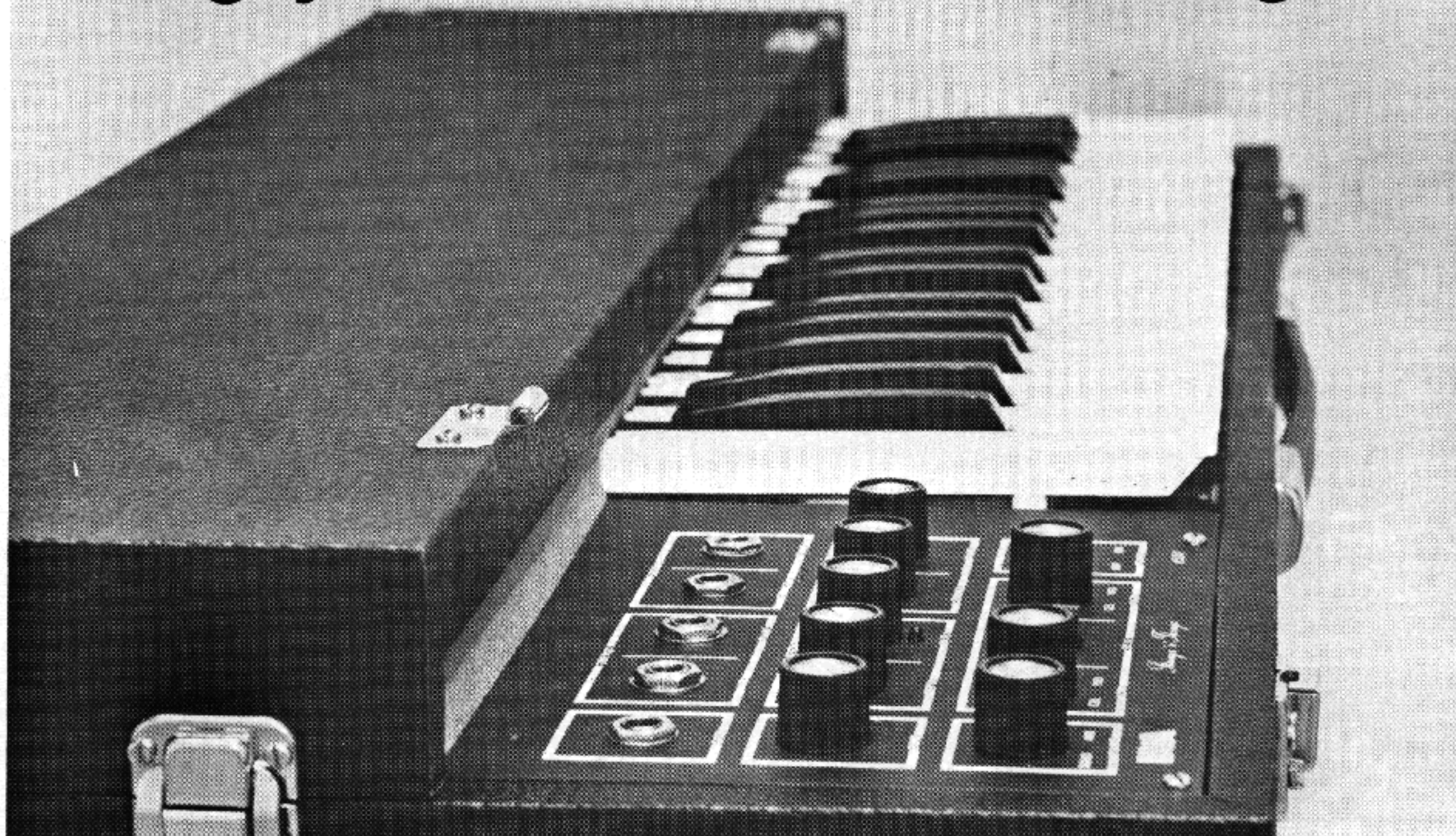

.... **OR they can have:** violins/cello/piano,
separate mixable piano output, synthesizer interface, variable
chorusing, variable sustain controls, jacks for foot controls,
keyboard split, dual violin/cello mixers, stereo string option,
even a modestly priced computer interface option.

You're gonna love it!

Stringz 'n' Thingz just \$295 from **PAIA**

TELL ME MORE

Send FREE CATALOG featuring this and other PAIA Kits.

Send Assembly and Using Manual for
STRINGZ 'N' THINGZ (\$5.00 enclosed)

name: _____

You've said enough, send complete kit for
STRINGZ 'N' THINGZ (\$295.00 enclosed)

address: _____

-shipped freight collect-

city: _____ state: _____ zip: _____

PAIA
ELECTRONICS

DEPT. 2-S, 1020 W. Wilshire Blvd., Oklahoma City, OK 73116 (405) 843-9626



Rosenboom:

Continued from page 19

the money came from his own personal indebtedness. He was absolutely dedicated to high quality publication so he didn't want to spare any expense in starting out right. I financed, along with John and J.B. Floyd, the records. So it was all out of our personal savings and scrapings together . . . John is the one who does most of the physical getting together of the publishing. My input is pretty much on the editorial side there. I do it more for the records."

So far ARC has printed two books by John Grayson (*Sound Sculpture and Environments of Musical Sculpture That You Can Build*), and one book edited by David (*Biofeedback and the Arts—results of early experiments*). Michael Byron is editor of *Pieces: An Anthology* and *Pieces: A Second Anthology*, which have included scores by such composers as Harold Budd, Philip Corner, David Mahler, James Tenny, Lou Harrison, David Behrman, Charles Amirkhanian, Frederic Rzewski, and Richard Teitelbaum among others.

This publication of ARC's has been particularly successful, with the first anthology going into a "hard back, gift edition." The second and the forthcoming third and fourth *Pieces*, however, are published entirely by Michael Byron, himself. There was originally a release of three records: "Suitable for Framing," David Rosenboom and J.B. Floyd, piano, with Trichy

Sankaran, south Indian mridangam; "Sounds of Sound Sculpture," made at the sound sculpture show in Vancouver, February, 1973; and "Brain Wave Music" which contained early bio-feedback pieces of David's.

This year's releases include an important document by Walter Zimmerman called *Desert Plants: Conversations with 23 American Composers. The Journal of Experimental Aesthetics'* first issue contains essays like, "META Meta + Hodos" by James Tenney; "Biofeedback with Cerebral Evoked Potentials and Perceptual Fine Tuning in Humans," by Christopher Mark Nunn; and an article about socio-political concerns in new music notation by Robert Ashley, entitled, "When The Virus Kills The Body and Is Buried With It, The Virus Can Be Said To Have Cut Its Own Throat: On The Problematic Nature of New Music Notation." It made its appearance this year, as did a series of books called *From The World Soundscape Project*, which at the time of the writing of these books was headed by R. Murray Shafer in Vancouver. This series concentrates on problems like "acoustical ecology" and what can be done about these conditions.

ARC's typical run is 1,000 copies. Rosenboom: "Even when a big publisher does a book about contemporary music like any of these, he really doesn't sell that many more than we do. The audience is very focused.

"You just have to contact the community you're speaking to yourself. It's pretty difficult to involve commercial distribution companies because they want such huge discounts that we can't afford to deal with them and survive on the quantities we print."

Beside spending his time with electronic music, David is also working on several instrumental scores. One wind piece was commissioned by a group in Canada called The York Winds, and makes use of some new approaches to the handling of contour shape information in computer composition routines. Another project is a record for the Ann Arbor Film Festival of new song poetry by artist Jacqueline Humbert. George Manupelli, founder of the festival and a teacher with David at York University, "is into making them and using them as a kind of gift to each film maker who enters." George, David, Jacqueline Humbert, Mary Moulton, and others have formed a group called *Maple Sugar*, which has done "improvisational opera" over the past year and this group will be making a new, full length film in the near future.

There is one more, by no means final, project which bears mentioning, that is, **Rosenboom:** "The development of a high level compositional language for implementing real-time compositional process in live performance. That's what I'm doing here with my instrument, but I want to develop a language which has a structure which is most ideally suited for composition in real time. And that may become standardized. I'll certainly publish things about it and present it in whatever form seems most useful. It's a big development project . . . and it is a time for me of getting down there and working on a number of pieces plus doing the research that leads up to the development of this language, which I see as a place where I'm going to pull together a lot of work I've been dealing with in the last few years, but haven't yet really applied." —VV—

Synapse

STUDIO or STAGE



IT'S A CLEAN SWEEP!

THE FLANGER 900-A MEETS THE CRITICAL NOISE AND DISTORTION REQUIREMENTS OF THE STUDIO WHILE MAINTAINING THE RUGGEDNESS AND VERSATILITY DEMAND-ED FOR STAGE USE. THE 900-A PRODUCES OVER 6 OCTAVES OF FLANGING WITHOUT INPUT ALIASING OR OUTPUT QUANTIZATION NOISE. PROBLEMS COMMON TO OTHER UNITS. BUT ITS VERSATILITY DOESN'T STOP HERE; OTHER EFFECTS SUCH AS DOUBLE TRACKING, PITCH SHIFT, CHORUS, VIBRATO, ROTATING SPEAKER SIMULATION AND CARDBOARD TUBE ECHO ARE EASILY PRODUCED. THE 900-A CAN BE EXTER-NALLY VOLTAGE CONTROLLED FROM VARIOUS CONTROL DEVICES.

SIMPLY THE FINEST ANALOG FLANGER AVAILABLE! INTERESTED? WRITE US.

WMS

WASATCH MUSIC SYSTEMS
805 EAST 3300 SOUTH

• PROFESSIONAL PRODUCTS DIVISION • DEPT. S
• SALT LAKE CITY, UTAH 84108 • (801) 467-4722

FREE

FENDER RHODES STAGE 73 PIANO

WITH PURCHASE OF OUR NEW

OR ARP OMNI POLYMOOG OBERHEIM

POLYPHONIC SYNTHESIZER



Only at the
ORIGINAL



Free!!! Echoplex
with purchase of our great

Arp Odyssey,
Minimoog or
Oberheim TVs

Open
7 days.

uitar Center

HOLLYWOOD · SAN FRANCISCO · SAN DIEGO

7402 Sunset
213·874 1060

928 Van Ness
415·441 4020

630 C St.
714·234-8731

by John Blacet

In any synthesizer system, the production of complex events is usually handled by an array of sequencers. In this project we will be looking at a VCC with an "event arranger" which may be thought of as a sequential base 2 timer having a range of 2048:1. The "event arranger" will trigger or clock external devices according to programs set up on front panel switches. The 12 timer outputs will span a wide range of time. For example, if the number one output is running at 10Hz, the output at 12 will change every 3.4 minutes.

Hardware

IC1 is a phase locked loop IC that contains a fairly linear VCO whose operating frequency is set by the 0.1 mylar capacitor, the RANGE control, the SPEED control and the voltage at either of the VC inputs.

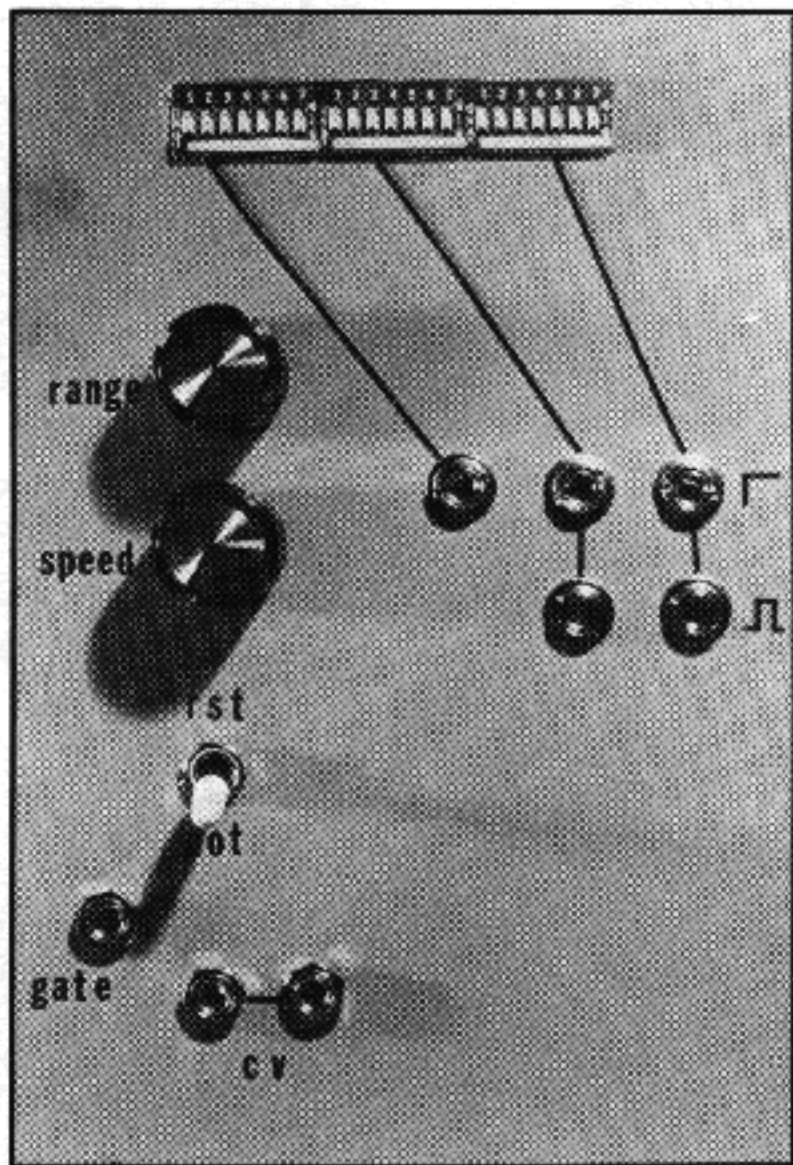

PHOTOGRAPH BY JOHN BLACET

Suggested front panel layout.

The exclusive OR gate is contained within IC1 and we are using it to gate the VCC on and off. By connecting the 1 M resistor from pin 14 to +, the VCC is wired on and does not require an input to operate. A low, or ground input will stop the clock. Wiring the 1M resistor to ground would have the opposite effect. The RST OR NOT switch allows you to optionally reset the sequential timer, IC2, when the gate input is low.

Clock pulses from pin 4, IC1 enter IC2 and are divided by 2 through 4096, appearing at pins 9 through 1 respectively. The clock pulses also serve to light an LED.

Miniature SPST DIP switches serve as the programming elements for three separate

CONSTRUCTION

Voltage Controlled Clock with Event Arranger.

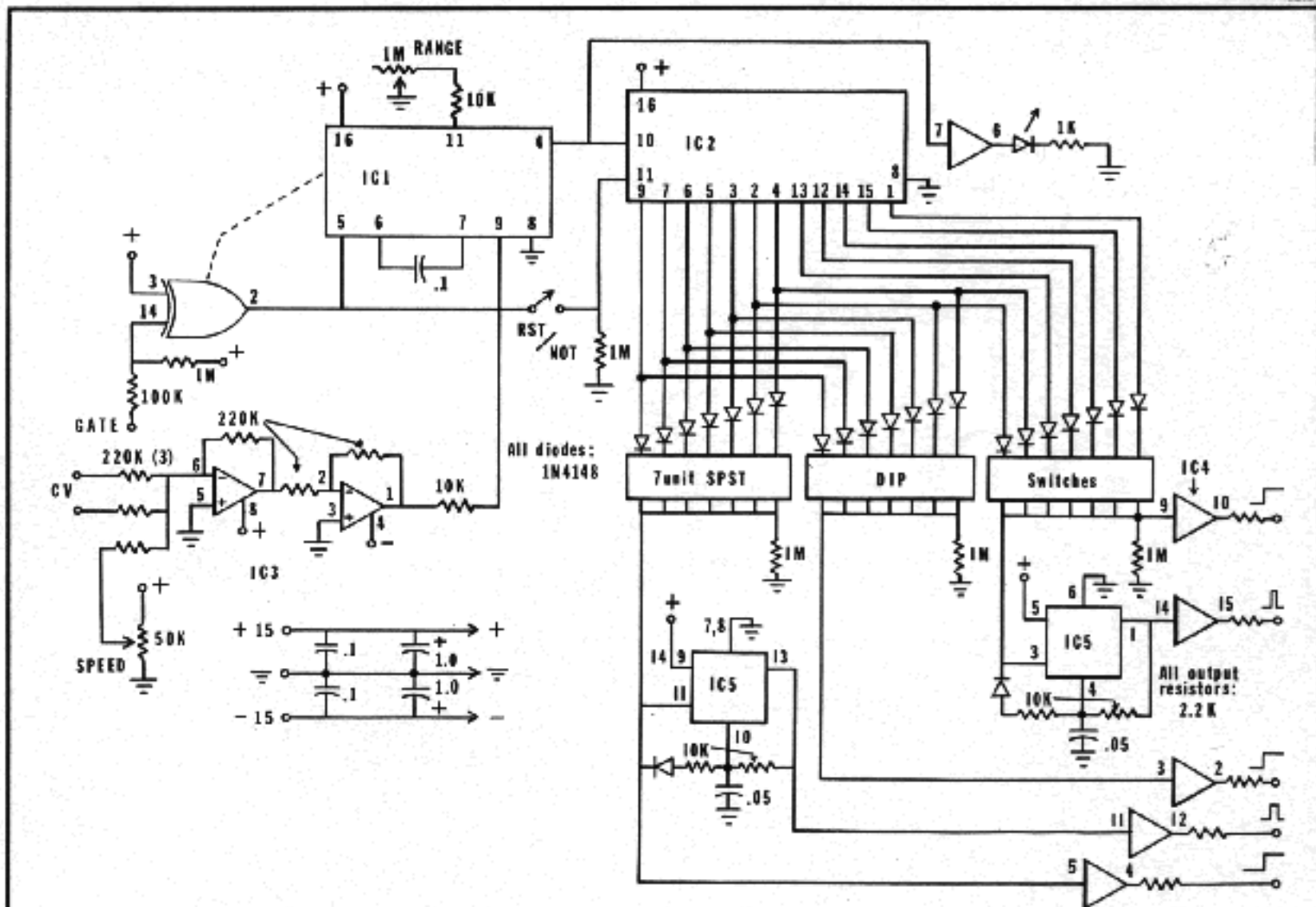

Above, voltage controlled clock schematic. Below, a sampling of event arranger settings and output patterns.

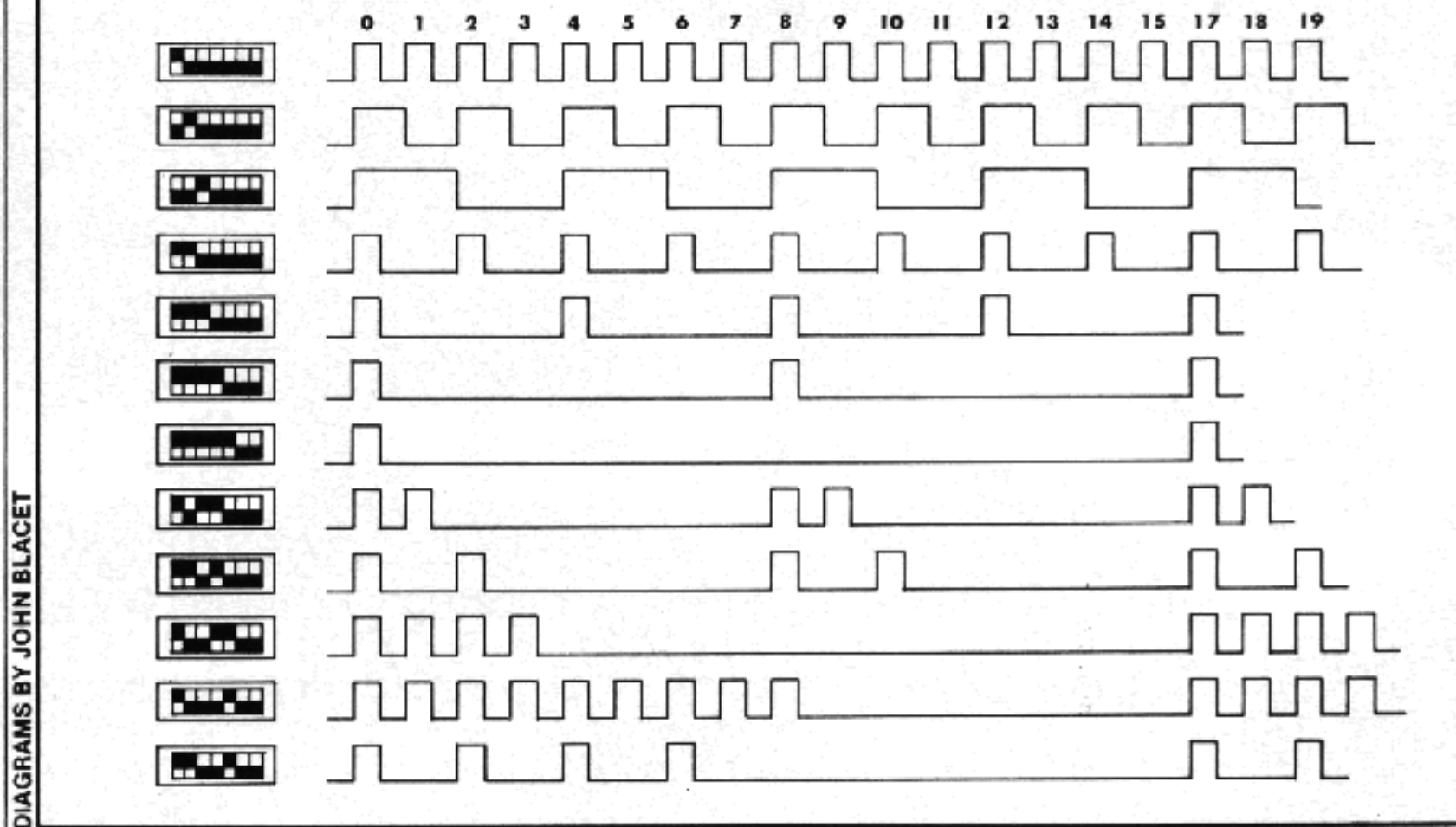

gate outputs and two trigger outputs. The first two switches are duplicates while the third one takes care of the longer delays and overlaps on the last two inputs of the first two. Trigger pulses are derived from the two

monostable circuits formed by IC5. This IC should be a "B" type in order to work properly.

A hex buffer, IC4, buffers all outputs. By the way, this IC will drive TTL type IC's

providing you eliminate the 2.2k output resistors and use a 5 volt supply for the IC only.

Additional outputs may be added by duplicating the diodes, switches, the monostable circuit for trigger pulses if desired, and the output buffer.

Construction

The circuit may be assembled by almost any method. The easiest route may be by using a general purpose p.c. board such as those sold by Radio Shack. The DIP switches were mounted directly on the board for the prototype. If all the wiring is kept below the level of the switch tops, the p.c. board may be mounted parallel to the front panel, with the switches protruding through a cut-out. Some shrink-fit tubing will come in handy for insulating the diodes.

CMOS IC'S are somewhat sensitive to static. Your soldering iron should be grounded and your clothing, general environment, etc. should be non static-prone.

Operation

Some of the various output patterns are shown in the diagram. Note the first three examples are square waves differing in frequency by multiples of two. The next four outputs show how to space pulses by multiples of two, by activating more than one

switch. The last five examples illustrate how to program two, four, or eight pulses with varying spaces between pulses and groups of pulses. The trigger outputs occur on the rising edge of the waveforms.

As a quick example of patching, connect a sequencer to the first switch bank, a percussion generator or VCF to the second and a balanced modulator to the third. Use the sequencer to drive a VCO, and use its pulse or square output for the second input to the bal. mod. Set up the switches to form an interesting pattern. Going further, use a control oscillator to voltage control the VCC and set the range control for the desired effect.

The voltage controlled clock and event arranger should help maintain coherency in complex sound events. Try to make full use of its extended timing range in your applications.

PARTS LIST

All IC's CMOS:		Capacitors:	
IC1 4046		1 .1 mylar	
IC2 4040		2 .05 disc	
IC3 5558 dual OP AMP		2 .1 disc	
(or other general purpose types)		2 1.0 electrolytic	
IC4 4050		Misc:	
IC5 4013 B (see text)		23 IN4148 diodes	
All resistors 1/4 watt 5%		1 LED	
1 1K		3 7 unit spst DIP switches	
5 2.2K		1 50 k linear pot	
6 10K		1 1M linear pot	
1 100K		1 spst switch	
6 220K		8 suitable jacks	
5 1M			

Synapse



Take the trouble out of tuning

Now, you can achieve instant, first-time, precision tuning of any instrument with the Korg tuner. Faster than strobes or pitch pipes, it permits both audio and visual chromatic tuning. It's easy to use and operate, and enables you to correct pitch discrepancies with your eyes or ears. Suggested list price, \$159.95, includes tuner, batteries, AC adapter and handy carrying case.

KORG Another superstar of sound from Unicord.
75 Frost Street, Westbury, N.Y. 11590

ARIES MUSIC
INCORPORATED

What's the connection here?

Almost every synthesizer has a keyboard, but not every keyboard player is a synthesist.

Aries makes modular systems for the musician who considers the synthesizer to be his primary instrument. Modular design allows complete control over pitching and normalled connections—thus each player can achieve a personalized repertoire of sounds.

Every Aries system is a custom design because every customer gets involved: choosing from our kits, modules and cabinets the kind of system he wants to use.

So if you play the synthesizer, and not just the keyboard, we think you've already made the connection. Call (617) 744-2400, or write:

Box 3065 Salem, MA. 01970

GUITAR SYNTHESIS

An Electric Bass Controlled Synthesizer

It's not surprising to find that many of the bassists and guitar players using synthesizers are regularly employed studio musicians. When it is necessary to produce the appropriate sound under time pressure one becomes inventive. How steady one's studio income is can depend on how useful you are to a producer. It helps to be able to do more than simply play an instrument well.

In the past five years keyboardists have been introduced to the synthesizer because it has been marketed as a keyboard instrument. Those readers who come from an academic background probably know the instrument as a voltage controlled, modular system more suited for manipulation by means other than a keyboard. Players involved in pop or jazz are more likely to be keyboard oriented.

Practically any instrument, electric or acoustic, is a potential synthesizer controller. While it can be argued that pitch followers and pitch to voltage converters (PVC) are still in their infancy, they do exist and they do work. Even without these devices the synthesizer is a potent processing tool of acoustic and electric instruments. But the range of possible sounds that can be produced with a guitar or bass is

dramatically increased given the capability of feeding a synthesizer a one volt per octave tracking signal from an instrument by way of a PVC.

Leon Gaer is one musician currently working in this way to further extend his instrument. A 23 year old Los Angeles area native, Leon has been keeping busy in the studios in between performing dates. In the past he's worked with jazz greats like Louie Bellson, studied with Laurendo Alameida, and currently performs with Don Ellis' group. He first became acquainted with synthesizers a little over a year ago. As a bass player he was frustrated with the lack of processors suitable for use with an electric bass. Wah-Wahs and the early phase shifters couldn't work effectively in the lower ranges as they did for guitar players. Then he found that parallel harmonies could be produced with a synthesizer by running his bass through a pitch to voltage device.

Leon began to study the problem. When he began, he knew nothing about synthesizers. After he acquired the terminology and a bit of insight into the various means of pitch following, Leon got himself a PVC and a small one voice synthesizer: "You have to learn all over, it's a whole new instrument. You have to

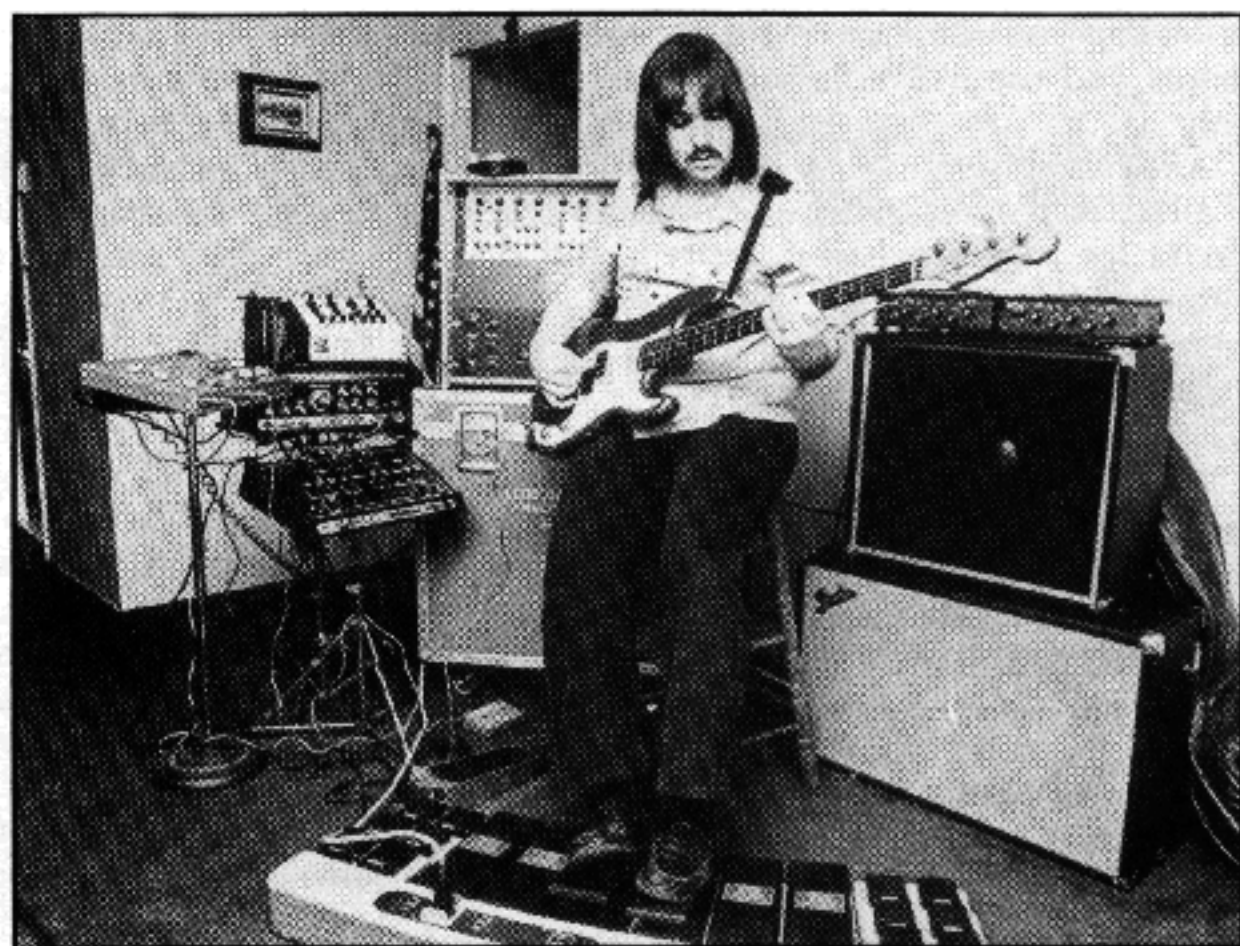

PHOTOGRAPH BY CHRIS DIERDORFF

Leon Gaer

research it, talk with players, hang out at a store, talk to the synthesizer salesman. There are so many terms for these things."

The process of pitch extraction can be troublesome. There a few microseconds between the time the note is picked on the bass or guitar and the time the correct voltage is produced. The key to designing a useful pitch follower is in how quickly the unit can "read" the note played. When a note is first picked a "thud" is read by the pitch extractor. This transient sound, or noise, is too rich harmonically to be read as a pitch. The thud must subside before the pitch can be identified. The voltages produced by the thud are sounded as a glitch by the synthesizer. A common solution to avoid hearing the glitches is to set the synthesizer's gate or envelope to open *after* the glitch. All guitar synthesizers dependent on pitch extrac-

tion and PVC's share this problem.

Meanwhile, Leon worked with his basic system. After becoming familiar with its triggering peculiarities, he took it with him on club dates and used that experience to determine what was needed to have a system controllable in real time. Unlike keyboard synthesizer players who often have a free hand to control their sound, guitarists and bass players keep both hands busy.

With the help of Wayne Yentis, Leon devised an interface system with foot pedals and switches that control the functions of the pitch follower, synthesizer, and processing devices normally manipulated by hand. His system now includes three Oberheim Expander Modules, a 360 Systems Bass Slavedriver (PVC), a Sequential Circuits Model 700 Programmer (64 patches!), Roland Space Echo, and a Mutron Bi-Phase. —Chris August

Advertisers' Index.

Analog/Digital Associates	p. 8
Aries Music Inc.	p. 45
ARP Instruments Inc.	p. 11
Sam Ash Inc.	p. 50
Audio Amateur Magazine	p. 48
Cat/Octave Electronics	back cover
CFR Associates	p. 48
Dennis Electronics	p. 50
E-bow/Heet Sound Products	p. 48
Electronic Music Laboratories Inc.	p. 21
Electronic Music Studios (London) Ltd.	p. 23
Gig Magazine	p. 49
Guitar Center L.A.	p. 43
Hound Dog Recording Studio	p. 50
International Musician and Recording World	p. 47
Korg/Unicord	pp. 9, 45

Media Mix	p. 26
Mellotron/Sound Sales, Inc.	p. 13
Oberheim Electronics	p. 3
Orchestron Sales Inc.	p. 31
PAIA Electronics Inc.	pp. 41, 53
Polyfusion Inc.	p. 27
Pro-Sound	p. 48
Rolandcorp U.S.	p. 7
Ken Schaffer Group	front inside cover
Sequential Circuits	back inside cover
Serge Modular Music	p. 47
Sound Arts	p. 40
Steiner Synthesizers	p. 52
Syndrum/Pollard Industries	p. 19
Wasatch Music Systems	p. 42
Wavemakers	p. 10
Yamaha International	P. 5
360 Systems	p. 15

Synapse

Back issues are available!
Get 'em while we got 'em!

QUANTITIES LIMITED

- | | |
|--|--|
| Volume 1 Number 1
<i>Interview with Alan R. Pearlman of ARP</i>
SOLD OUT! | Volume 1 Number 2
<i>Interview with Morton Subotnick</i>
SOLD OUT! |
| Volume 1 Number 3
<i>Kraftwerk, Tom Oberheim of Oberheim Electronics</i>
SOLD OUT! | Volume 1 Number 4
<i>Malcom Cecil & TONTO, Bob Easton of 360 Systems</i>
SOLD OUT! |
| Volume 1 Number 5
<i>Interviews with Pat Gleeson and Gary Wright</i>
\$1.75 | Volume 1 Number 6
<i>Roger Powell & Todd Rundgren, Synthesizers on the Eco-Front</i>
\$1.50 |
| Volume 2 Number 1
<i>Robert Moog, Herbie Hancock, George Duke</i>
SOLD OUT! | Volume 2 Number 2
<i>Tangerine Dream, Bernie Krause, Synthesized Video</i>
SOLD OUT! |
| Volume 2 Number 3
<i>Tomita, Stockhausen, Home Recording, Guitar Synthesis</i>
\$1.50 | |

Add 50¢ first class postage and handling for each copy ordered.

All of you interested in the unavailable issues please send postcard requests for our files. When we have enough requests we'll be able to do reprints.

Synapse Back Issues

2829 Hyans Street Los Angeles, California 90026

Buy Synapse Here:

□ **AUSTRALIA** Air Freight to the **Music Distillery** Brookvale, distributed to: **Abraxas**, Wagga Wagga; **Farrell Keyboards**, Brookvale; **Regent Music**, Adelaide; **Warehouse Sound**, Victoria; **Zenith Music**, Claremont. □ **CANADA** **Atlantic News**, Halifax; **Richard's Music Shop**, Montreal; **Pushkin's Depot**, Toronto; **Paradox EMS**, Vancouver; **Guitarland**, Winnipeg. □ **CALIFORNIA** All **Music Plus** stores. **Berkeley**: International News, Rather Ripped Records; **Beverly Hills**: Pico-Robertson News; **El Cajon**: Blue Meanie Records; **Hollywood**: Guitar Center, Guitar Villa, Musician's Contact Service, World Book & News; **Long Beach**: Whittaker Music, Zed of London Records; **Los Angeles Area distribution by Bookman Distributors and Levity Distributors**; **Oakland**: Leo's Music; **Ocean Beach**: The Black; **Orange**: Record Trading Center; **Pacific Beach**: Licorice Pizza; **San Diego**: Guitar Center, Sound West, Tower Records; **San Francisco**: Guitar Center; **San Francisco Bay distribution by Serendipity Couriers**; **San Luis Obispo**: Square Deal Records; **San Rafael**: Bananas At Large; **Santa Barbara Area**: Castle Music, Fancy Music, Jensen Music, Morninglory Music, Turning Point Records, Valley Music; **Santa Clara**: Byte Shop No. 2; **Santa Cruz**: Book shop Santa Cruz; **Santa Monica**: Lincoln-Pico News, Papa Bach Paperbacks; **Sherman Oaks**: Baxter-Northrup Music; **Solana Beach**: Isness Records; **Sunnyvale**: Recreational Computer Center; **Van Nuys**: Computer Components; **West Covina**: Hanich Music; **West Los Angeles**: Rhino Records; **Whittier**: Whittier Professional Music. □ **COLORADO** **Mountain States distribution by High Paper/Boulder**; **Denver**: Schaeffer Enterprises; **Englewood**: Byte Shop. □ **CONNECTICUT** **Danbury**: Danbury Electronic Music. □ **FLORIDA** **Hallendale**: Clean Music Systems; **Lynn Haven**: Jan's. □ **ILLINOIS** **Chicago**: Barbara's Bookstores, Volume One, Five West Randolph; **Evanston**: Chicago Main; **Highland Park**: Gary Gand Music; **Hoffman Estates**: Reader's World; **Marissa**: Ye Olde Music Shop. **Plus Chicago Area distribution by Gulliver's Periodicals**. □ **INDIANA** **Indianapolis**: I.R.C. Music. □ **KANSAS** **Manhattan**: Rush Street Exchange. □ **KENTUCKY** **Bowling Green**: Fairview Plaza Music Center. □ **LOUISIANA** **New Orleans**: Allied Music. □ **MARYLAND** **Randallstown**: Randallstown Music. □ **MASSACHUSETTS** **Boston**: E.U. Wurlitzer, Pampalona's; **Waltham**: Computer Mart. □ **MICHIGAN** **Ann Arbor**: Community News; **Canton**: Arnoldt Williams Music; **Dearborn**: Dearborn Music, Little Professor; **Detroit**: Bookworld; **Ecorse**: Booknook; **Farmington**: Fireside Bookstore; **Oakpark**: Little Professor; **Oxford**: Book Place; **Pontiac**: Front Page Books; **Royal Oak**: Mickey Shorr; **Saginaw**: Bay Music; **Taylor**: Open Book Store; **Distribution throughout Michigan by Big Rapids Distributing**. □ **MISSISSIPPI** **Crenshaw**: The Music Men. □ **NEVADA**: **Las Vegas**: The Drum Shop. □ **NEW JERSEY**: **Paramus**: Sam Ash. □ **NEW YORK** All **Sam Ash Music Stores**; **Manhattan**: Gramercy Park; News & Books 73 Irving Pl., Grand Central Station; Hello Newsstand 3rd Ave & 42 St NW, Greenwich Village; Candy Store 242 W10th St, General Store Carmine St, West Side Book Store W8th St & McDougal St, Herald Square; Newsstand 6th & 35th, Lincoln Center; Newsstand 66th & Broadway NW corner, Lower East Side; East Side Bookstore St. Mark's Pl, Saint Mark's Bookstore 13 St. Mark's Pl, Rockefeller Center Newsstand 6th Ave & 50th St SE corner; **White Plains**: Jack Bronen's Music. □ **OHIO** **Cleveland**: Mayfield Music, Pl Corporation. □ **PENNSYLVANIA** **Bryn Mawr**: Medley Music; **Roselle**: Roselle Music. □ **TENNESSEE** **Memphis**: Strings & Things; **Nashville**: Music Man. □ **VIRGINIA** **Norfolk**: Ambassador Music. □ **WASHINGTON** **Seattle**: The Electronic Music Box. □ **WISCONSIN** **Appleton**: Beggar's Tune; **Eae Claire**: Trucker's Union; **Madison**: Lake Street Station, Ward-Brod Music; **Milwaukee**: City News, Disco-Tech, University Store; **Racine**: Beautiful Day; **Waukesha**: Main Stream. □ **JAPAN** Distribution by **Music Joy Distributors** and **ASCII Publishing**.

Synapse

We'd like you to know about Serge Modular. We make what may be the most precise and versatile synthesizer system in use today. The Serge Modular is available either fully assembled or in money saving kit form. We made it modular, to assure that a musician (or video or computer artist, for that matter) can put modules together to fit his or her specific needs, and also to make room for future expansion of a Serge System. We adhere to industry standards such as 1 Volt per Octave VC Inputs etc. to allow easy interface between Serge Systems and other synthesizers. We made it as versatile as we could within the state of the art, because we wanted to expand the possibilities of synthesis, not to limit our equipment to a few pre-patched effects. We made it innovative, because our pursuit of the highest quality allied to an affordable price made it hard not to be innovative, and because we are basically research rather than commercially oriented.

Affordability, versatility, precision, and an expanding universe approach to the design of music modules, these are the key notes of Serge Modular Music Systems....

A few specifics about our hardware: We make the trackingest VCO, be-

tween 40° to 100° F. Our top of the line oscillators track one another within 1k less than a cycle over the entire range of human pitch perceptible sounds. Our new VCA's and Panners feature over an 80dB S/N, and at least a 60db rejection of control voltage. Many of our modules are patch programmable. This means that they may be patched to perform several functions which in traditional synthesizers would take several (costly) modules. For example, our Dual Negative Slew, can be patched to function as Envelope Followers with voltage controllable

decay rate, as log linear VC timing pulse generators, as sawtooth audio VCO's and LFO's, as portament devices, as envelope generators (when allied with their sister module, the Dual Positive Slew). We feature single or double sided fiberglass boards, A-B hot molded audio potentiometers, and the highest quality components wherever necessary to assure the best performance. We've experienced less than 2% failure rate over four years of production, and countless systems and modules delivered to individuals, universities, and commer-

cial studios. When we ship an assembled system, it is totally burned in, calibrated, and guaranteed 2 years parts and labor. When we ship a kit, we try as best as we can to make even the inexperienced kit builder an instant success. We ship only preassembled and fully tested PC boards.

We wish we could tell you more about Serge Modular. Being innovative, and not necessarily falling under run of the mill categories, our modules may cause some consternation. Wherever possible, we'll gladly arrange a live demonstration in your neighborhood. (We find our customers are our best sales people.) If that's not possible, we'll gladly answer your questions by return mail. Meanwhile, you may wish to order a packet of information concerning Serge Modular, consisting of a variety of new product announcements, our catalog & price list, and a short Instruction Manual. All that we ask of you is to send us \$2.00 for the packet, and your name and address to:

Serge Modular Music Systems
1107 1/2 N. Western Avenue
Hollywood, CA. 90029
(213) 461-7987

serge modular music systems

BOW YOUR GUITAR

with The First Electronic Bow For The Guitar — the **E-Bow**

Tired of the same old show? Picture what a violin bow does for the violin . . . the range of sounds, the dynamics, the life the bow gives the violin. Imagine what you could do with a device that would bow your guitar string electronically . . . the Energy Bow.

Hand held, the E Bow is swept over the string to control harmonics and envelopes, allowing the guitarist to shape the sounds of violin, flute, cello, oboe, horn, synthesizer, and reverse tape effect. Total control of attack, sustain and decay at any volume.

Not a pedal or plug in . . . the E Bow is battery powered, completely self-contained. No hook up. Emitting an intense magnetic field, the E Bow operates directly on the guitar string NOT ON THE SIGNAL FROM THE PICKUP. You owe yourself, your music, and that lonely old axe of yours the chance to come alive. EXPLORE A WHOLE NEW DIMENSION. INFINITE SUSTAIN and so much more!!! Get to your music store for a live or taped demo. NOW.

SPECIAL OFFER — HEAR THE REMARKABLE E BOW

For Demo cassette send \$1.00 U.S. to cover postage and handling to:

E Bow T-Shirts: \$4.50
plus 50c to cover postage
and handling. (S, M, L)

Heat Sound Products
611 Ducommun Street
Los Angeles, Ca. 90012
Phone: (213) 687-9946

Distributed in Australia by:
The Music Distillery
Brookvale, N.S.W. 2100
Phone: 938-2372



FOR A GREAT AUDIO ADVENTURE

A new, exciting discovery in great sound awaits you in *THE AUDIO AMATEUR MAGAZINE*.

It's delightfully easy to improve, maintain, and even build your own audio components. Thorough articles—everything from amps to speakers, simple add-ons or improvements to intricate modifications—help even our non-technical readers develop superior sound equipment.

Subscribe now on a guaranteed satisfaction basis or send for our FREE prospectus.



HANDY COUPON

Fill in the coupon, include a check or money order payable to *The Audio Amateur* and send to TAA Dept. S1, Box 176, Peterborough NH 03458 USA.

- Enter my sub for TAA for one year/four issues for \$9.
- I want to know more. Enclose \$2.50 plus .50 cents postage for the current issue of *The Audio Amateur*.
- Send free prospectus.

Name _____
Street _____
City _____ State _____
ZIP _____

Foreign subscriptions are \$10 per year and all remittances must be in US funds.

JAN HAMMER

Continued from page 30

Synapse: Are there people that you feel have heavily influenced you on the level of melodic writing and structure?

Jan: Well, of course a lot of European classic composers. I studied classic composition when I was in Prague before I came over here. That was my major and I've written quite a few things and I feel that was the most important influence on the way I write as well as play. Even though I've forgotten most of the exact concepts

Synapse

SYNTHESIZER EXPERIMENTERS SPECIAL

TAU SYSTEMS 1230 VCO MODULE
SAWTOOTH, 1HZ-30KHZ
1.8" SQUARE, £18 V.
only \$19.90 10V P-P, SYNC
LIN, EXP'L.

but that's not all!!

We also have a 1024 stage Analog Shift Register (identical to the SAD 1024, 16 pin plasDIP. Use it in flangers, phasers, echo and other outasight things. ONLY \$14.00ea

CFR associates write for our catalog
box F
Newton NH 03858

For Immediate Delivery of

audio accessories

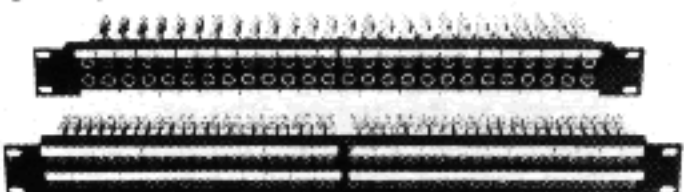
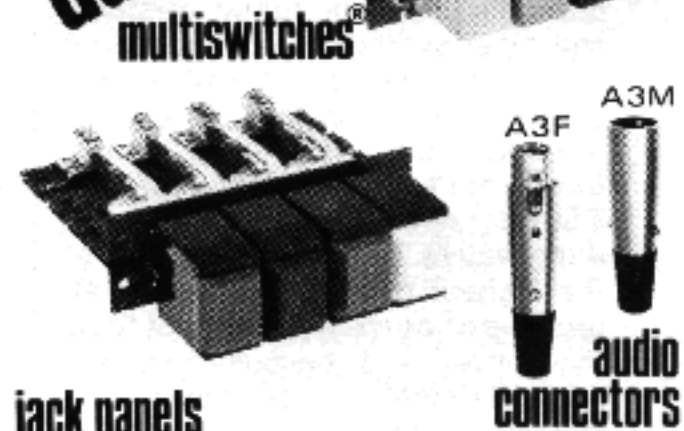

Send for our FREE CATALOG!

CALIFORNIA SWITCH & SIGNAL
A complete line of audio accessories
OEM Prices • Immediate Delivery
13717 S. Normandie Ave., Gardena,
California 90249 (213) 770-2330

of composition those things are deep in my subconscious and they are shaping what's coming out. And in addition to that it's the inspiration which is not learned, it's something that, you know, I was born in a certain part of the world and it shows.

Synapse: Are there players in contemporary music that you find influential whether they're synthesizer players or not?

Jan: The only person that always comes to mind is Jimi, but he's dead. Jimi Hendrix. He's very much alive for me and I don't know . . . everybody seems to be going towards the jazzier side and I'm going the other way now and so I can't even tell.

Synapse: When you were still doing fusion music or jazz/rock or whatever one is supposed to call it, did you feel that within the music industry you were being categorized?

Jan: Well, I was also getting lost in the vast ocean of my copies. Now there are over 50 groups trying to sound like Mahavishnu Orchestra and in the ears of the public they are succeeding, but it just dilutes the market. There are 400,000 people that bought "Birds of Fire," our best selling album. If you divide the audience between the 50 groups, you can't have real large followings for 50 groups that sound the same. I was caught up in that and people

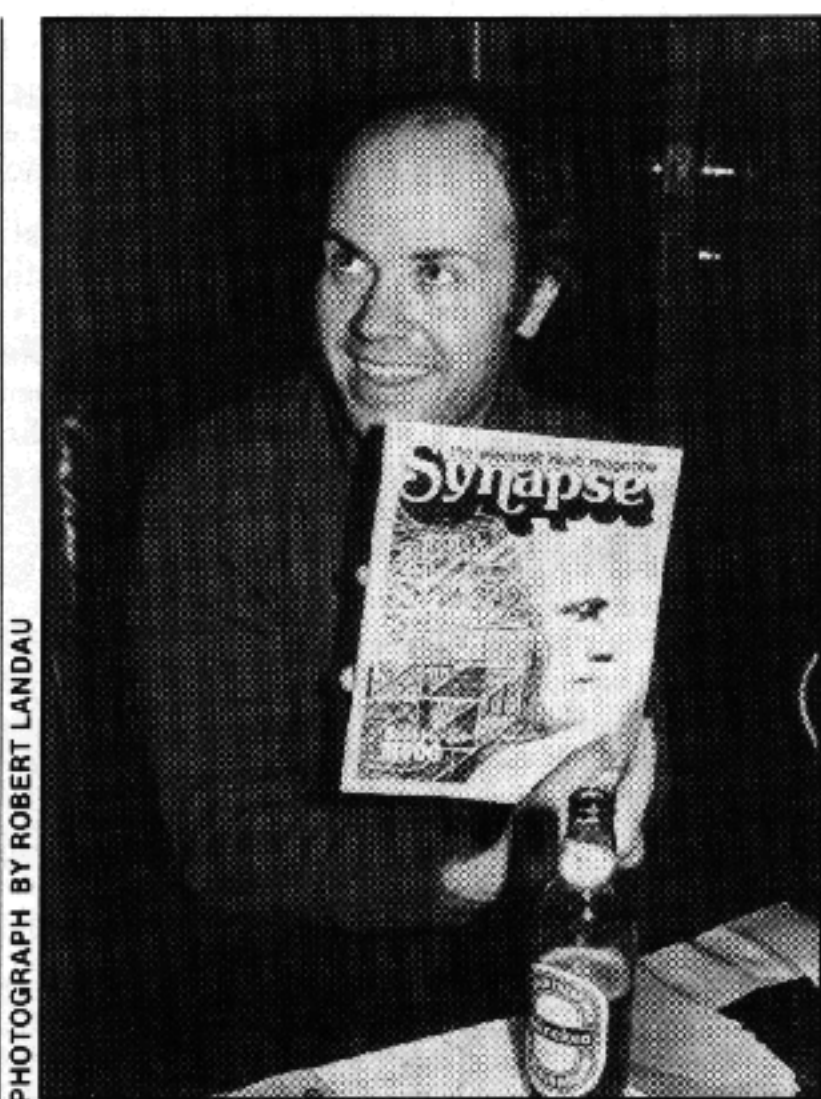

PHOTOGRAPH BY ROBERT LANDAU

Jan Hammer with our favorite magazine and beverage.

could not tell the difference and I don't blame them because it is a lot of fast notes and you need a musical education to be able to really appreciate something that's that complex. People just are not musically

educated, that's the fact . . . and there's no point in making music for musicians, and there I go again.

Synapse: I'm interested to know how you approach the synthesizer as a player and as a composer. What aspects of it technically become paramount in importance and what techniques do you really feel you have room to grow with? I know of course the pitch bending.

Jan: Sure—the urgency too—I go after the most urgent sound and it's always a two-way thing. It's not only the instrument, it's also the ears of the person who's playing it. It's just like studio engineering, which is another thing I'm involved with and you can say that you cannot get a good sound on this equipment and you can on that but it's not really true. You can give the same synthesizer to four different guys and have them play with it for a while and sounds will come out radically different. It's really very much an infinite sort of instrument. You can have totally different sounds coming out of four different people. It's the same for engineering.

Synapse: Engineering and synthesizers are extremely close. As a matter of fact I can't imagine that they won't be in the board one day and they already are to a certain degree.

Jan: Right. At home when I work that's how I work. It's all part of one console. ~~~

Synapse

How much do you know about guitar synthesizers?

Unless you're an expert you need International Musician and Recording World to explain. In a current issue International Musician and Recording World has gathered together the Roland, the ARP and the Hagstrom and compared them. A panel of famous guitarists was invited to visit and test all three. Afterwards they were privately interviewed about their preferences. The report appeared as an eight page special. International Musician and Recording World is the biggest Musical Instrument magazine in the world. If you haven't seen it you don't know what's happening in instrument technology. To help you find out we're prepared to send the next 12 issues to your post box for \$13.50. That's 25 per cent below the usual price and postage is free.



Yes please send me the next 12 issues of International Musician and Recording World. I enclose my cheque for \$13.50 and I understand that covers all postage and packing.

Name
 Street No.
 Street.
 City.
 Zone

Send to:
 International Musician and Recording World,
 501 South Main Street, Spring Valley, N.Y. 10977

EQUIPMENT

μ 4060 Series Polyphonic Keyboard and Sequencer

Until recently, synthesizer technology left the musician essentially 3 choices: a pre-set synthesizer for fast but limited patch changes, a modular system for complex voltage control patches but restricted use of keyboard voices, and "polyphonic" synthesizers consisting of frequency division sound generation or limited number of voices (up to 8). The advantage of this μ keyboard/sequencer is in having the capability of 16 independent voices, provided of course that one also has the 16 VCO's, VCA's and envelopes. The fully developed system (\$4110) with all the necessary extra memory modules (CMOS16K ram boards with battery backup. The keyboard above is \$2500 and stores 60 key depressions) is capable of storing 6,000 key depressions.

The 4060 consists of the following: a faceplate with jacks for 16 control voltages and 16 gates, each of which has three outputs, and corresponding amber lights indicating which channels are activated. This module would be located in the cabinet. The keyboard has five octaves and a controller section with cassette input/output for storing patches on tape, an external clock input, internal clock rate control to slow or speed up the sequenced tempo, an offset pot for transposing 5 semitones in either direction, a portamento controller, reset switch to erase the memory, an error/battery indicator and a calculator type 16 key touch pad keyboard used in defining operating modes and functions . . . this last item is the main goody. A 16 channel Zilog Z-80

microprocessor is the heart of the system. Outside of private custom designs, the Roland Microcomposer and this system are the best examples of how digital technology will influence synthesists and increase the powers of realization in real time.

The calculator keyboard has two modes of operating: without a prefix, or with a "D" prefix which increases the modes and functions controllable by the microprocessor (see diagram). Some examples: touching the keys D, 3, and then a note on the keyboard splits the keyboard in such a way that the note depressed be-

sequence is played on the keyboard. The sequencer remembers the control voltage, gate, glide state and channel assignment for each note played.

Depressing O stops storage and determines the end of the sequence at the instant the key is depressed. To recall a sequence, the character "" along with the sequence number are depressed, and the sequence begins playing and recycles at the end of the sequence.

The nice feature is the ability to "overdub" sequences in such a way that as you hear the last one played, the new voice is synchronized and can be played independently (that is the old and new control voltages are separated and capable of being edited without affecting any other information stored in other channels). Thus the amazing possibility of sitting

output. Naturally, other modules besides oscillators may be controlled from these 16 outputs. For example, 6 channels may be implemented in controlling 6 VCO's while 3 channels may control 3 filters, while 4 other channels control ADSR transient parameters, (the envelope or transient generator module has voltage controlled delay, attack, decay, sustain, release) while 2 other channels control the dry/reverbed mix of 2 stereo outputs. Also, that would still leave an extra channel of control voltage to be implemented . . . perhaps to control the sequence tempo (internal clock rate). Gates could be used to step sample/hold modules, trigger transient generators, analog sequencers, and the like.

Voltages and gates may be stored on tape by depressing D and the character "#", undergoing error checking procedures as the information is dumped on tape. If an error is detected, the error light stays on. Recalling from tape is accomplished by depressing D and the character "", loading the sequencer memory from tape.

Other functions of the keyboard include the circular assignment of channels on a rotating basis (depress 6), the transposition of the sequence being recalled (depress 3 and a note from the low C representing the interval desired), and converting the keyboard to the unison mode primarily for tuning purposes.

The reader is directed to μ's reprint presented at the Audio Engineering Society convention (May 10-13, 1977) where a more technical description of the functions and design rationale is given by the designers Scott Wedge and Dave Rossum.

The μ keyboard is available separately to be interfaced with other brands of synthesizers, though the manufacturer points out that casings for an μ power supply and output panel are necessary. They also express an order of preference for interface, that being: Oberheim (to whom they license some of their keyboard technology), Moog modular 921 VCO's, ARP 2600, and Mini-moog . . . They point out, however, that the keyboard is compatible with any quality 1 volt/octave synthesizer.

—Alex Cima

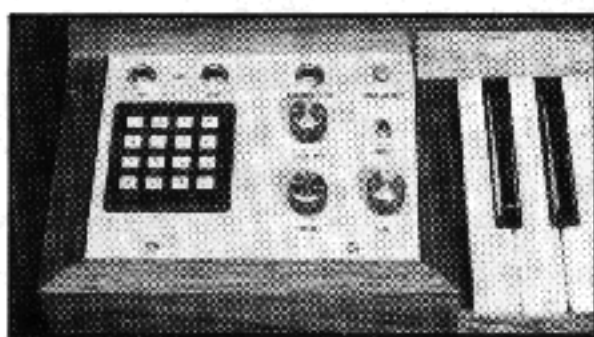

Above left, a close-up of the μ Microprocessor Keyboard control panel. The 16 channel polyphonic output panel is shown above right.

Bottom, a complete μ modular synthesizer with the Microprocessor Keyboard.

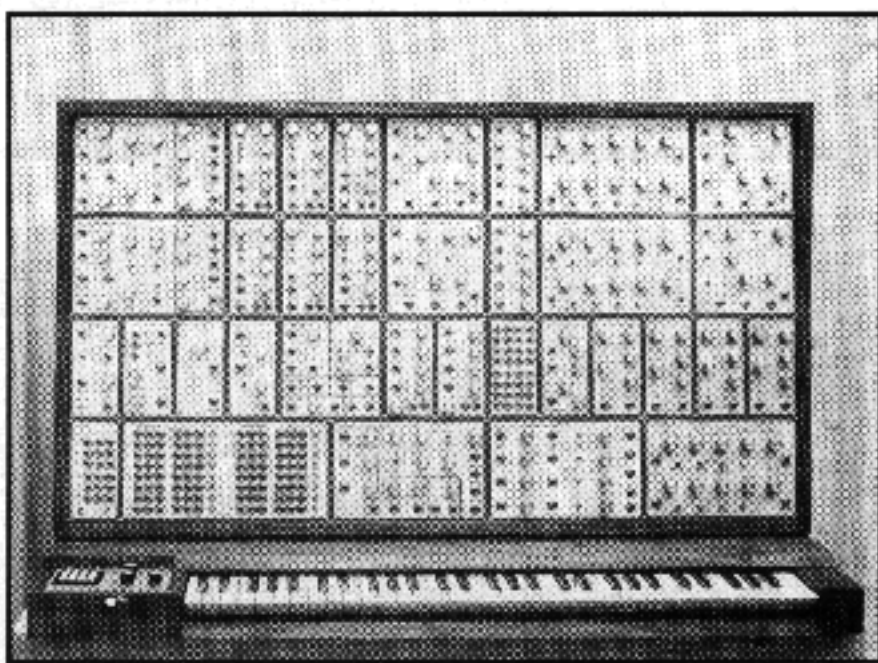
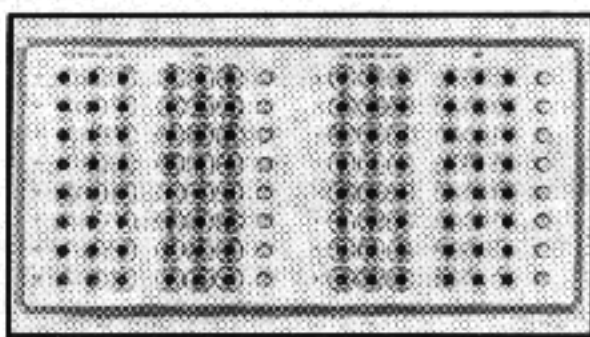

comes the top note of the lower section; each section can be given portamento (glide) independently. To store a sequence, one would first depress the character "#" and a number. The channel would then be erased and readied for the new information, which is promptly memorized as soon as the first note of the

at home composing independent voices (percussion, strings, or, if you prefer, modulation patches of spacey and avant garde quality), then walking into a recording studio with all your memorized note depressions and gates and immediately dumping them on 16 track recorders, or mixing directly from the synthesizer

Synapse

**N.Y.'S DISCOUNT
MUSIC DEPT STORE**
JUST A FREE CALL AWAY!
800-645-3518
SAM ASH MUSIC STORES

Buy at discount direct from our 6 huge stores and warehouse. All musical instruments, amplifiers, electronic keyboards, discos, PA's, pianos, organs, accessories, music. Call for prices or mail your list of questions. NYC area residents, please visit us in person. NY state phone 212 347-7757. Since 1924

HOUND DOG RECORDING

FREE 16 TRACK TIME

DETAILS · (213) 449-8027

Expand your
SYNTHESIZER'S
capabilities
with the
DENNIS

Control Voltage Processor

Dennis Electronics

2130 Metcalf Street,
Honolulu, Hawaii 96822

TOO ROLLING STONED?

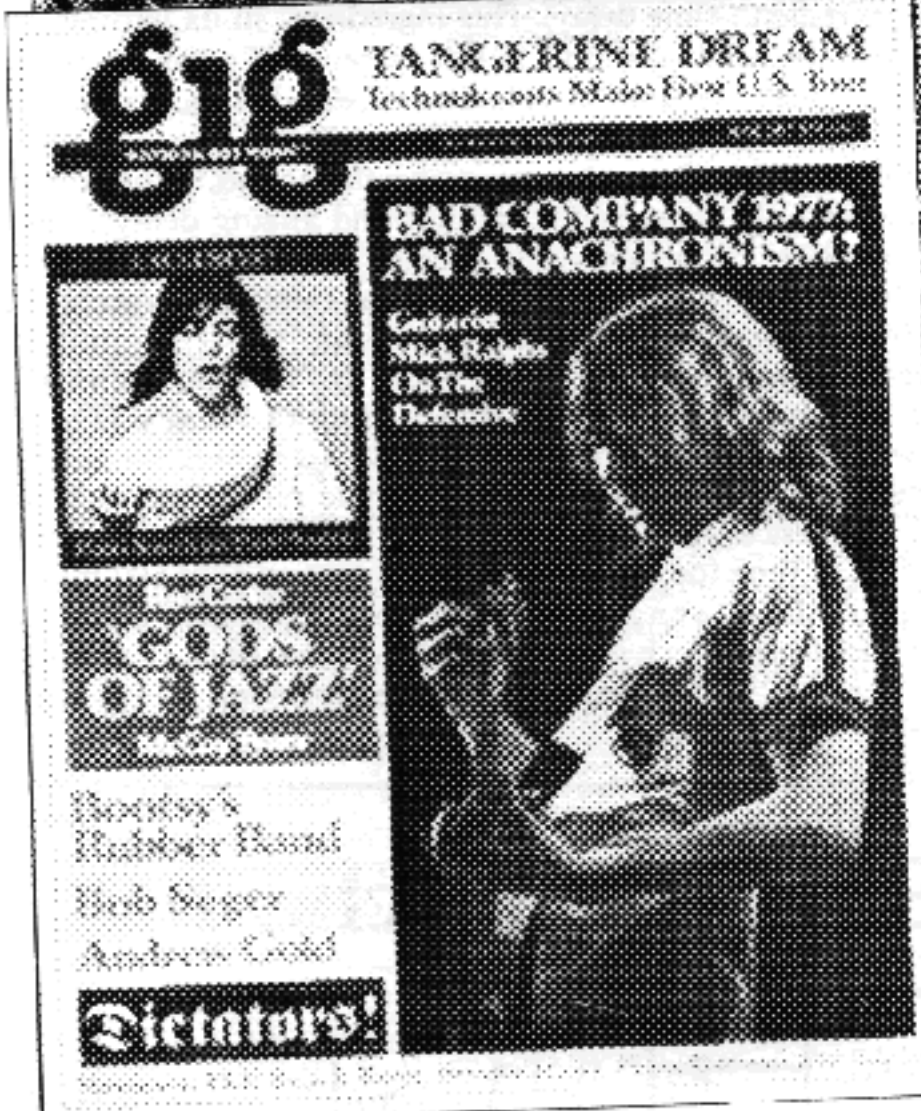

*It's time
you tried*



THE NATIONAL TABLOID THAT'S ALL MUSIC!

- Probing, provocative news and features
- In-depth interviews with the Cream of the Pop
- Professional coverage of Musical Instruments, with GIG's "Road Tests" reviews
- Audio/Hifi: news and honest evaluations of the latest audio equipment
- More record reviews than anybody — rock, jazz, classical, obscure, and more
- The GIG Charts; up to date top of the pops — albums and singles
- Lavish illustration and clear, forthright graphics
- Pictorial peeks at the social side of rock and roll
- And much much more!

If You're Into Today's Music-

You Can't Make It Without A GIG!

YES. I want to read about music in my music magazine. Send me the next 9 issues of GIG for just \$4.99 — a 35% saving on the regular newsstand price. If I'm not satisfied I understand I can cancel at any time—for any reason—and receive a full refund on all unmailed issues.

Name _____

Address _____

City/State/Zip _____

MAIL TO: GIG Magazine, 415 Lexington Avenue, New York, N.Y. 10017
Outside the U.S. add \$1.50 additional postage.

GIG1

STEINER SYNTHESIZERS



The Microcon

The Steiner Microcon is a complete synthesizer (less keyboard) in a single module. It has its own power supply, VCO, LFO, VCF and envelope generator, thereby combining all of the most needed parts of a synthesizer in one unit.

It can be used with synthesizer accessories such as sequencers, electronic valve instruments, guitar slave-drivers, pitch followers, or with a keyboard. Multiple units can be combined with a guitar controller to form full polyphonic synthesizers at a fraction of the cost normally expected. Combined with a regular synthesizer, it adds an extra "voice" to your present system.

Oscillator stability and tracking are the best that state of the art will allow. Numerous inputs and outputs are available on the front and top of the unit. Other signals available inside can be brought out for special applications, and connected to other equipment in a variety of useful ways.

CONTROLS: VCO-course, fine, three waveforms • LFO-level, rate, beat, vibrato • VCF-frequency, gain, resonance • EG-attack, decay, sustain, damp • VCA-trigger controlled audio gate • + and - triggers out • VC filter in • calibrated and uncalibrated VC in • signal out (can be paralleled) • trigger in • beat function-causes and VCO to sound like two oscillators beating together • List \$300.00 •

STEINER SYNTHESIZERS

2734 So. 2700 West, Salt Lake City, Utah 84119
(801) 972-1447

SYNTHESIS

Ambience: Part One

Are you having trouble putting life into your synthesizer? Are your saw-tooths dull? Do your square waves droop? Is your space dead?

Well, put a little perspective into your sounds! Take command of your environment! What you need is a bit of ambience!

Yes folks, a little ambience can go a long way towards making a work of "art" out of those blips and blurbs coming out of your synthesizer!

Ambience is the environment in which sound takes place. Ambience is made of a single ingredient: time delay. This ingredient, in its various forms, when combined with the original sound, creates a sense of perspective, a warmth of sound not produced by other so called cold remedies, and a feeling that, yes, you really are there!

A signal delay is produced by recording the sound, either on to magnetic tape or an electronic memory (ex. digital and analog delay), and playing it back moments later. Short delays (5-50ms.) can be used to fatten the sound (similar to tuning 2 or more oscillators so that they beat slightly), longer ones can create the feeling of playing in a large canyon.

By re-recording the delay, over and over (fig. 1), echo is created. Echo can really give a sound a spacey effect, rebounding to infinity. Three head tape recorders work well for this (using 3 3/4 ips is my favorite) and, of course, echo devices are made specifically for multiple repetitions of sound. Digital delays and their less expensive analog counterparts will do echo effects as well, but the optimum time for echo is 1/3 to 1/2 second (300-500 ms.), and many electronic delay lines won't delay that long. However, digital and analog delays perform delays much shorter than most tape units can. A tape recorder running at 15 ips will delay sound approximately 65 ms., while most electronic delays work as short as 1 ms.

Figure 1a: Echo patch

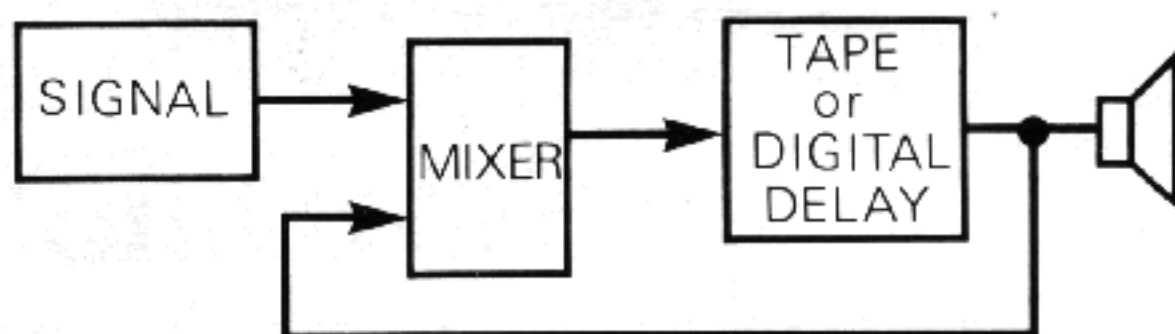
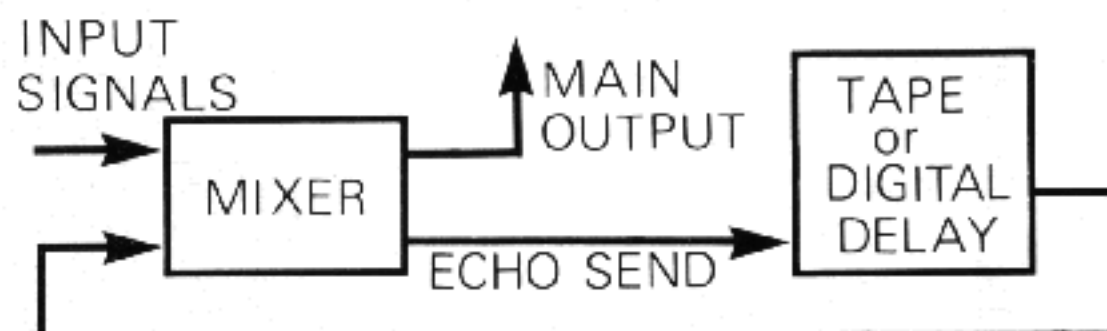

Figure 1b: Elegant echo patch



In both patches:
three-head tape recorder in
record mode, monitor from tape.

Synapse

Basically, the difference between multiple echo and reverb (or chamber echo), is similar to the difference between audio and sub-audio modulation: the echoes produced by tapes or longer delay lines can be heard individually, while an echo chamber produces echoes of the original signal so rapidly that the brain cannot differentiate one repetition from another. For this reason, very short digital delays also produce good reverb.

The shortest delay the brain can distinguish as a disparate sound is approximately 32 ms. In a natural acoustic environment, such as a large concert hall, the delay repetition is approximately 50 ms. behind the original sound, with the delay time of each successive repetition about half of the one before it, until they dissolve into reverberant sound and fade away, absorbed by the building and people. It takes about 2 seconds for the reverb to decay (realize that all of these figures depend on the size of the space and the amount of sound absorbing material in the space).

Reverb units follow the scheme of decreasing delay, more or less, and the reverb units with variable decay time (\$1500 and up) enable one to dial the "size" of the room. The accompanying table shows how reverb decay time corresponds to room size.

Type of environment	Reverb decay time in seconds
outside	no reverb to speak of (highly variable if sound bounces off buildings)
office	.2
office conference room	.4-.8
chamber music room	1.0-1.3
concert hall	1.5-2.5
cathedral	2-4

While the reverberation repetition rate and decay time subjectively determine how large the space is, the mixture of "dry," original sound, and the delayed sounds determines how close the sound is to the listener. Thus, the sound can be made to recede into the distance by mixing the dry sound progressively softer relative to the delayed sounds.

I've written this first installment about natural environments and the creation of natural ambience. However, the synthesizer enables you to create ambience that could not occur in a purely acoustic situation and it is these unnatural environments that the next column will address.

—Danny Sofer

DISCOLA

continued from page 17

music, be it baroque or rock, on the synthesizer.

My terms having been defined, this record of electronic music by percussionist Donald Knaack contains realizations of conceptual pieces by two of the best known "conceptors" around, Marcel Duchamp and John Cage. The "Erratum Musical" (1913) consists of a method to compose the piece, which Knaack composes/performs three times simultaneously on various glass instruments of his own creation.

Duchamp's method for composition requires the following: a large funnel, five open wagons connected and numbered balls, one for each of the sounds that can be produced by the set of instruments being used. The balls are placed into the funnel and fall at random into the wagons which are pulled under the funnel. The balls are then removed from the wagons, notating the order in which they are removed. The duration of

each event is then determined by dividing the time period assigned to each wagon by the number of balls in it, resulting in a piece with five sections.

This realization consists of soft pastel sounds that are frequently intruded upon by loud clanging ones. It seems rather busy, but that may be because one hears three versions of the piece at once.

27'10.554" (1956) is written for metals, wood, skin percussion instruments and an "all others" category which may include electronic devices, mechanical arrangements, radios, or whistles. The structure of the piece is designed to present a constant flow between the sounds of the instruments and the sounds of the silences in the music. Why Knaack recorded the synthesizer first instead of playing all the instruments at once is beyond me, but in any case, the electronics blend in well with the metals, woods, and skins and the long silences in between.

—Danny Sofer

"the Craig Anderton Music Tape"

His monthly column in *Guitar Player* magazine ... articles in *Electronotes*, *Popular Electronics*, *Synapse*, and *Contemporary Keyboard* ... the best selling book, "Electronic Projects for Musicians" and its follow-up, "Home Recording for Musicians" ... these have combined to establish Craig as a leading figure in the hybrid field of musical electronics.

What few people know is that he has played and composed music continuously for 18 years, performed on stage and TV, and has worked in the recording studio from 4 different angles: recording artist, session player, producer of other artists, and engineer.

"The Craig Anderton Music Tape" is over 37 minutes of original music, composed and played by him in a home studio environment. It ranges from semi-classical to humorous, from soft to hard. As an added bonus, an explanatory booklet accompanies the tape that includes lyrics and details on how the various effects were accomplished.

This unique tape is available in cassette format for \$5.95 plus 50 cents handling. Send orders (Mastercharge® and VISA® cards accepted) to:

PAIA Electronics, Inc.
1020 W. Wilshire Blvd.
Oklahoma City, OK 73116

You may also order via PAIA's 24 hour demo/phone line at (405) 843-7396.

LISTINGS

"Listings" is provided as a service to Synapse readers. Please make full use of these addresses and let those you write to know you found their address in Synapse. Readers with suggestions for additional listings write: Synapse/Listings, 2829 Hyans St., LA, Ca. 90026.

Synthesizer Manufacturers

Advanced Tools for the Arts, P.O. Box 825, Tempe, Ariz. 85281
Analog/Digital Associates, 2316 Fourth St., Berkeley, Cal. 94710
Aries Music Inc., P.O. Box 3065, Salem, Mass. 01970
ARP Instruments, Inc., 45 Hartwell Ave., Lexington, Mass. 02173
Audio Arts, Inc., 5615 Melrose Ave., Hollywood, Cal. 90038
Blacet Music Research, 4019 Chico Ave., Santa Rosa, Cal. 95401
Buchla, Box 5051, Berkeley, Calif. 94705
CFR Associates*, Box F, Newton, N.H. 03858
Computone Inc./Lyricon, P.O. Box 433, Norwell, Mass. 02061
Concert Company**, 3318 Platt Avenue, Lynnwood, Calif. 90262
Dataton AB, Box 257, S-581 02 Linkoping, Sweden
D.B.L. Electronics, 502 Sherman, Canton, Mass. 02021
Dennis (Electronic Music Components), 2130 Metcalf, Honolulu, Hawaii 96822
Electrax, P.O. Box 149, Tarzana, California 91356
Electron Farm/Harvest, Gregory Kramer, 135 W. Broadway, New York, N.Y. 10013
Electronic Music Laboratories, P.O. Box H, Vernon, Conn. 06066
Electronic Music Studios, The Priory, Great Milton, Oxford, England
E-mu Systems, 3046 Scott Blvd., Santa Clara, Calif. 95050
Farfisa, 1330 Mark St., Elk Grove Village, Ill. 60007
Galaxy Systems, P.O. Box 2475, Woodland Hills, Cal., 91364
Gentle Electric, 140 Oxford Way, Santa Cruz, Cal. 95060
Heuristics, Inc., 900 N. San Antonio Rd., Los Altos, Cal. 94022
Inner Space Electronics, Box 308, Berkeley, Cal. 94701*
Ionic Industries, 128 James St., Morristown, NJ 07960
Korg/Unicord, 75 Frost Street, Westbury, N.Y. 11590
Logistics, Box 9970, Marina Del Rey, Cal. 90291
Media Mix, 4060 Stanford, Dallas, Texas 75225
MM Electronics, French's Mill, French's Rd., Cambridge, England CB4 3NP
Moog/Nordin, 7373 North Cicero Ave., Lincolnwood, Ill. 60646, Customer Service: 2500 Walden Ave., Buffalo, N.Y. 14225
Musicomputer, 15, 112 W. Sierra Hwy., Canyon Country, California 91351
Music Technology/Crumar, 105 Fifth Ave., Garden City Park, N.J. 11040
Musitronics Corporation, Sound Lab 10, Rosemont, N.J. 08556
New England Digital Corp., P.O. Box 305, Norwich, Vermont 05055
Oberheim Electronics, 1549 Ninth St., Santa Monica, Calif. 90401
Octave Electronics Inc., 35-73 Steinway St., Long Island City, N.Y. 11103
Octron, 1348 Bayport Avenue, San Carlos, Calif. 94070
Omniphon, Box 166, Churchill Rd., Mason, N.H. 03048
Oznite Process Electronics, Box 7, Centerville, Penn. 16404
PAIA*, Box 14359 Oklahoma City, Okla. 73114

Pollard Industries, Inc., 9014 Lindblade St., Culver City, Cal. 90230
Polyfusion Inc., 160 Sugg Road, Buffalo, N.Y. 14225
Rocky Mount Instruments, Inc., Macungie, Penn. 18062
Rolandcorp U.S., 2401 Saybrook, L.A., Cal. 90040
Sapetelli Music Systems, P.O. Box 40267, San Francisco, Cal. 94140
Scalatron/Motorola, 2130 N. Palmer Dr., Schaumburn, Ill. 60196
Sequential Circuits, 1172-G Aster Ave., Sunnyvale, Cal. 94086
Serge Modular Music, 1107 1/2 N. Western Ave., Hollywood, Calif. 90029
Software Technology Corp., P.O. Box 5260, San Mateo, Cal. 94402
Solid State Music, 2102A Walsh Ave., Santa Clara, Cal. 95050**
Star Instruments Inc., Box 71, Stafford Springs, Conn. 06076
Steiner-Parker, 2258 South, 2700 West, Salt Lake City, Utah 84119
Stramp, 3-2000 Hamburg 53, Bornheide 19, Germany
Strider Systems, P.O. Box 2934, Norman, Okla. 73070
Syn-Cordian, 32-73 Steinway St., Long Island City, N.Y. 11103
Syn-Key, 114 W. Hintz Road, Wheeling, Ill. 60090
THINC-Technical Hardware Inc., P.O. Box 3609, Fullerton, Calif. 92634
VAKO Synthesizers Inc., 4651 62nd Avenue North, Saint Petersburg, Florida 33565
Wavemakers, P.O. Box 27, Edmonds, Wash. 98020
Yamaha International, Box 6600, Buena Park, Calif. 90620
360 Systems (213) 384-8447. 2825 Hyans Street, Los Angeles, Calif. 90026

Note: * manufacturer makes kits only
** manufacturer makes both kits and finished product

Consultants

Audio Designs, 3422 Brookfield Ln., Decatur, Georgia 30032 (404) 284-8651
BASS, 37 Sussex, San Francisco, Cal. 94131
Michael J. Boddicker, (213) 985-0010
Boston Experimental Electronic Music Projects, Robert Ceely, 33 Elm St., Brookline, Mass. 02147, (617) 731-3785
Clean Music Systems, 131 S. E. Fifth St., Hallandale, Fla. 33009, (305) 454-4601
Danbury Electronic Music Center, 84 Federal Rd., Danbury, Conn. 06810 (203) 792-2794
Different Fur Music, John Vieira, 3470 19th St., San Francisco, Calif. 94110, (415) 863-WAVE
Disco Tech Musical Electronics, Prospect Mall, 2239 North Prospect, Milwaukee, Wisconsin 53202 (414) 271-9291
Dorje Sound, Chet Wood, P.O. Box 2232, Berkeley, Calif. 94702
DS Music, 811 Franklin St., Santa Monica, Calif. 90403, (213) 463-8772
Electronic Music Consulting, Michael W. Gilbert, 104 Riverglade, Amherst, Ma. 01002 (413) 253-2786
Electronic Music Studio, Dwight D. Gatwood, Director, University of Tenn., Martin, Tenn. 38238 (901) 584-7402, 578-2281
EMSA (Electronic Music Studios of America, Inc.), 269 Locust St., Northampton, Mass. 01060 (413) 586-3777
Entropy West Electronics, Eric Valinsky, 1242 Harvard St., Santa Monica, Calif. 90404 (213) 828-0389
Exploratory Electronic Music, Steven C. Bilow, 16685 Calneva Drive, Encino, California 91436 (213) 789-6885
Keyboard Services, P.O. Box 975, Baton Rouge, La. 70821 (504) 924-3858
Laine Research & Development, P.O. Box 3219, Fullerton, Cal. 92634 (714) 871-1923

COMPUTERS

S/H and A/D Conversion

with Peter Hillen

Last time we saw how the sample and hold, (S/H), took a great burden off the Analog to Digital (A/D) Converter both in terms of speed and cost. The reason for this is that the S/H is used to sample quickly changing waveforms and then hold them for further conversion by the A/D Converter. The A/D Converter can then do its conversion between samples rather than doing it very quickly right at the sampling time. The exact time the sample takes place is called the aperture time, and can be a very small time period several times smaller than the time between the sampling periods.

There are a couple of other parameters important when considering a S/H. The first is acquisition time. The acquisition time is the time it takes the S/H to make its output equal to the voltage it is sampling. After the voltages are equal, then the output tracks the input exactly. When the sample command is given, the output is frozen. The time it takes to freeze the output is called the aperture time. The input, of course, will continue on. If another sample is to be taken, then the S/H must "acquire" the input and track it again. The acquisition time is dependent on several things but the greatest factor is charging and discharging the storage element during the acquisition time which is a capacitor. This brings the acquisition time in direct conflict with another important parameter, namely droop. When the input signal is sampled, we naturally assume the sample value stored stays on the output of the S/H indefinitely. Not so. Since the sampled voltage is stored as a charge on a capacitor, it can leak off. The resulting decay in voltage is called droop. Droop can be a problem if the sampling rate and the A/D Converter are slow. The A/D Converter will be converting a changing voltage which is what the S/H was supposed to cure. The solution is to use a larger capacitor to store the sampled voltage. But, here is the problem. A larger capacitor requires longer to charge so it takes longer to acquire a voltage during acquisition time. A balance must be struck between acquisition time and droop. There are many other variables which can be controlled to lead to a satisfactory solution.

Let's now turn our attention to how a S/H works electrically. Figure 1 shows a very simple circuit consisting of a switch and a capacitor. The switch is normally open. When the switch is closed, the input is connected to the capacitor. The capacitor charges or discharges depending on whether the input is greater or less than the charge on the capacitor before the switch was closed.

After some time, the input and the capacitor voltage will be equal. The time from when the switch was closed until they are equal is the acquisition time. The switch is opened and the capacitor holds a charge equal to the input at the time of the opening. The voltage on the capacitor will slowly droop because of the leakage of the capacitor itself and whatever it is connected to on the output.

Figure 2 contains a schematic of a S/H which is simple to use. The biggest difference between it and the circuit in figure one is that the mechanical switch has been replaced by an electronic one. The electronic switch is a Field Effect Transistor (FET). A FET is comprised of a thin piece of silicon connected between two terminals known as Source (S) and Drain (D) and a diode connected from the silicon to a terminal known as the Gate (G). By applying a negative voltage to the Gate with respect to the Source, it is possible to establish a large electric field

Figure 1: Simplified Sample & Hold.

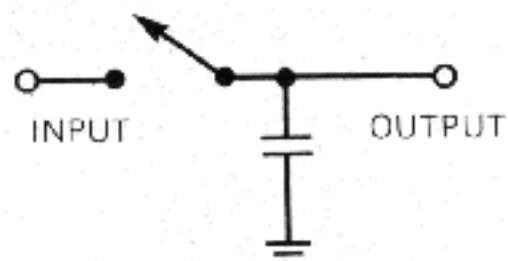
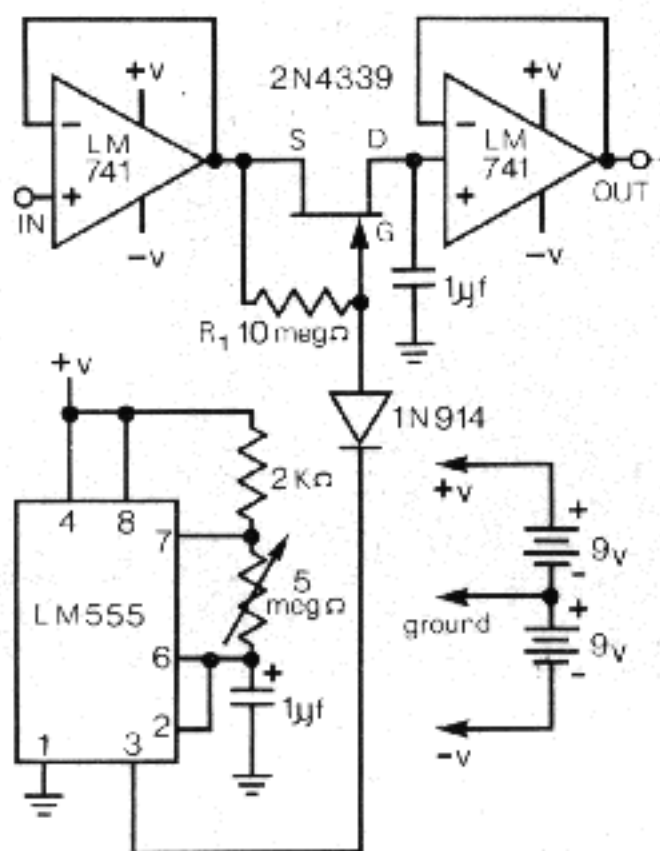

Figure 2: Complete Sample & Hold Circuitry.



DIAGRAMS BY SUE DENIM

which will pinch off the silicon channel and make it a very high impedance. This condition is the same as placing the mechanical switch in the open position. When the negative voltage is removed, the Source and Gate are at equal voltages because of the resistor R_1 . The channel resistance is low and can be considered like the switch in the closed position.

The op amp preceding the FET Switch acts as a buffer between the signal being sampled and the sampling capacitor. The op amp on its input provides a high input impedance so it does not disturb the circuitry to which it is attached. Its output is powerful enough to charge and discharge the capacitor so the acquisition time is not too long.

The op amp on the output is connected in a similar way for the same reason. Its input is measuring the sampling capacitor. It must be high impedance to minimize leakage so there is not too much droop. The output is powerful enough to drive circuits which follow.

The final element in the circuit is the low frequency oscillator. Its output goes between +9 and -9 volts. At -9, the channel is cut off and the signal cannot pass to the capacitor. At +9v, the diode is back biased and the Gate and Source are at the same voltage, which allows the signal to pass freely. The pot adjusts the frequency of the sample rate.

Using this circuit or the S/H built into a Synthesizer, we can demonstrate some of the concepts we have been talking about. First is the sampling rate. Connect the input to a slow moving sawtooth wave (one ramp every 2 or 3 seconds) and connect the output to a VCO at some medium audible frequency. Now turn the sample rate to the highest frequency. Depending on the frequency of the sample, it should sound like a continuous slide or a staircase with very close increments. It should sound similar to the sawtooth connected directly to the VCO. This is because the sample rate is very high so the resolution is great. Now turn the sampling frequency down. The steps get more pronounced and the jump in frequency between steps get wider. It should still sound like a staircase or at least an ascending range of frequency but much less like a frequency ramp. Now turn the sawtooth frequency up until it is higher than the sampling frequency. The effect is of random frequency output. The reason is that the sampling frequency is less than twice the frequency being sampled (see last issue's article).

Droop can be demonstrated by placing a DC voltage on the input to the S/H and a VCO on its output. Sample at the slowest rate possible, even to the point of disconnecting the oscillator. The droop will be reflected as a drop in frequency. It will be so gradual that our ears may not be able to hear it until the next sample restores the capacitor to the correct value.

Lectron Music Lab, Box 1594, Hollywood, Calif. 90028
Stan Levine, 13508 Debell St., Pacoima, Calif. 91331 (213) 899-7223
Sound Arts, 2825 Hyans St., Los Angeles, Calif. 90026 (213) 487-5148
Paradox EMS, Inc., 116 West Broadway, Vancouver, B.C., Canada V5Y 1P3
Patchwork Sound, Jack Howe, 14759 Hesby St., Sherman Oaks, Calif. 91403
People's Computer Company, P.O. Box 310, Menlo Park, Calif. 94025
Pi Corporation, 1741 East 24th St., Cleveland, Ohio 44114 (216) 781-2207
Ron Rivera, 48 Brighton Avenue, No. 11, Allston, Mass. 02134
Ed Schaeffer Enterprises, P.O. Box 26521, 1049 S. Garland Way, Denver, Colorado 80226 (303) 988-9090
Dr. Philip Springer, Box 1174, Pacific Palisades, Calif. 90272 (213) 454-5275
Star Track Recording Studio, 8615 Santa Monica Blvd., Los Angeles, Calif. 90069, (213) 855-1171
Carter Thomas, Manpel Road, Spring Glen, N.Y. 12483 (914) 647-9121
TNY Music & Engineering, Route 4, De-freestville, N.Y. 12144 (518) 283-2837, 283-2899

FRAP, Box 40097, San Francisco, Calif. 94140 (415) 824-2223
FROGG (Design Engineering Labs Inc.), 4121 Redwood Ave., Los Angeles, Calif. 90066 (213) 823-8220
Hammond, 4200 Diversey, Chicago, Ill. 60639
Heil Sound Systems, Heil Industrial Blvd., Marissa, Ill. 62257
Infitheatre Inc., 4990 Mass Ave., Indianapolis, Ind. 46218
J.D. Electronics, Inc., P.O. Box 2205, Berkeley, Cal. 94702
Marshall Electronic, Box 177, Joppa, MD. 21085
Mellotron/Sound Sales Inc., Sherman, Conn. 06784
Morley Electronics, 2301 West Victory Blvd., Burbank, Calif. 91506 (213) 843-7122
Musico, 1225 N. Meridian St., Indianapolis, Ind. 46204
Pro Sound, 13717 S. Normandie, Gardena, Cal.
Rothchild Musical Instruments (distributor Furman and Alembic products), 65 McCoppin St., San Francisco, Calif. 94103 (415) 626-2260
The Ken Schaeffer Group, 10 East 49th St., New York, New York 10017
Sennheiser Electronic Corp., 10 West 37 St., New York, N.Y. 10018
TAPCO, 405 Howell Way, Edmonds, Wash. 98020 (206) 775-4411
Wasatch Music Systems, P.O. Box 9175, Salt Lake City, Utah 84109

Schools

BEEP Electronic Music Workshops, 33 Elm Street, Brookline, Ma. 02146 (617) 731-3785
Boston School of Electronic Music, 127 Kilsyth Rd., Brighton, Mass. 02135 (617) 734-4500/4501
Con Tempo Music Guild, 13273 Ventura Blvd., Studio City, California 91604 (213) 784-8271
James D. Craig Music, 511 Cedar St., Allentown, Penn. 18102 (215) 437-4743
Dick Grove Music Workshops, 12754 Ventura Blvd., Ste. 2, Studio City, Calif. 91604
Los Angeles Center for Electronic Music, 8615 Santa Monica Blvd., Los Angeles, Calif. 90069 (213) 652-7655, 463-8772
Omega Intermedia Center, 3433 North Halsted, Chicago, Ill. 60657 (312) 477-9863
Sherwood Oaks Experimental College, 6353 Hollywood Blvd., Hollywood, Calif. 90028 (213) 462-0669

Sound Products & Accessories

Alembic, P.O. Box 759, Sebastopol, Calif. 95472 (707) 823-8579
Barcus-Berry, 15461 Springdale St., Huntington Beach, Cal. 92649
Carvin Music and Sound, 1155 Industrial Ave., Escondido, Cal. 92025
E Bow/Heet Sound Products, 611 Ducommun St., Los Angeles, Calif. 90012 (213) 687 9946
Electro-Harmonix, 27 West 23rd St., N.Y., N.Y. 10010
Electro-Voice, 674 Cecil St., Buchanan, Mich. 49107
Eventide Clockworks, Inc., 265 West 54th St., New York, N.Y. 10019 (212) 581-9290

Sound Recording

Ampex, 401 Broadway, Redwood City, Calif. 94063 (415) 367-4544
dbx Incorporated, 296 Newton St., Waltham, Mass. 02154 (617) 899-8090
Dokorder, 5430 Rosecrans Ave., Lawndale, Calif. 90260
Dolby Laboratories Inc., 731 Sansome St., San Francisco, Calif. 94111 (415) 392-0300
Furman Sound, 616 Canal Street, Suite 25, San Rafael, California 94901 (415) 456-6766
Magnetic Reference Laboratory Inc., 229 Polaris Avenue, Suite 4, Mountain View, Calif. 94043 (415) 955-8187
Maxell Corporation of America, 130 West Commercial Ave., Moonachie, New Jersey 07074
Orban/Parasound, 680 Beach St., San Francisco, Calif. 94109 (415) 673-4544
Otari Corporation, 981 Industrial Road, San Carlos, California 94070 (415) 593-1648
Scientific Audio Electronics Inc., P.O. Box 60271, Terminal Annex, Los Angeles, Calif. 90060
Scotch/3M Magnetic Audio/Video Products Division, 3M Center, Saint Paul, Minn. 55101
Scully Recording Instruments, 475 Ellis St., Mountain View, Calif. 94943
Shure Brothers Inc., 222 Hartrey Avenue, Evanston, Ill. 60204
TDK Electronics Corporation, 755 Eastgate Blvd., Garden City, N.Y. 11530
TEAC Corporation of America, 7733 Telegraph Road, Montebello, Calif. 90640
Telex Communications Inc., 9600 Aldrich Avenue South, Minneapolis, Minn. 55420

Classified Ads

Classified Ads: Synapse provides classified ad space at a minimal cost as a service to our readers. Ads from instrument dealers are no longer accepted. 20 words or less \$2.00, 40 words or less \$5.00, 60 words or less \$15.00. Enclose payment with ad and send to: Synapse/Classified Ads, 2829 Hyans St., Los Angeles, CA 90026.

Scanning to form omnipotent electronic synthesizer symphony. Must have control over synthesizers and all other keyboard symmetry. Must be into sounds of Tangerine Dream, Klaus Schulze, Pink Floyd and in that music direction. I have control over a studio and some of its contents, like a modified Oberheim Polyphonic Synthesizer, PAIA 2720 R synthi, Sequential Circuits 800 Digital Sequencer and some sound enhancement like a 3340s Teac open reel, DBX, Altec Lansing No.

9's, Accu-phase E-202 amp., and about 10 bits more. Let's make musik. Seek and find yourself (212) 848-1773 Tom Gadomski 164-24 98th St. Howard Beach, New York City, New York.

Release yourself from the constraints of the keyboard. Play with expression heretofore known only to the violinist, guitarist, and hornist . . . Get yourself a Joystick kit from Mediamix. Also used EML 500 available. Mediamix, 4060 Stanford, Dallas, TX. 75225. (214) 368-6846.

Wanted: Volume 1, issues 1, 2 & 3 of Synapse. State price and condition. Val Wise, Box 188, Las Cruces, N.M. 88001.

EML Polybox—mint condition, as reviewed here. Cost \$500.00, sell \$350.00 or best offer. (212) 254-5531 Eric.

Continued from page 10

... New from Star Instruments Inc. is the Synare 2 Percussion Synthesizer. The instrument is a melodically conceived percussion system designed to realize a full range of percussive sounds including mallet instruments. The unit is digitally tuned in half-tone steps controllable by 12 pressure pads. Also included is a sequencer that can be loaded in

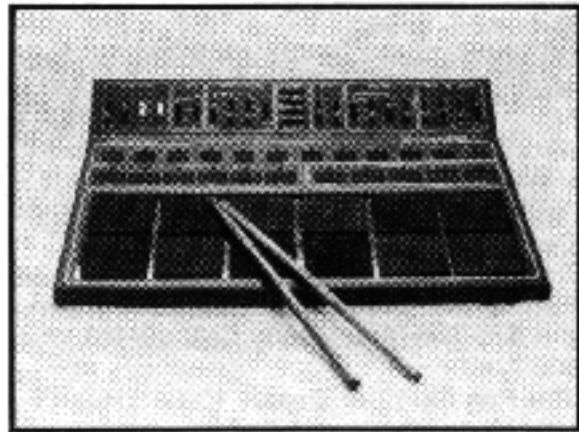

Star Instruments Synare 2.

real time and played along with by the performer. Featured is a three waveform LFO and VCO, pulse width modulation from either the LFO or envelope generators, white and pink noise, VCF, and a VCA. Most functions are able to be controlled by drum sticks or hands. The instrument lists for \$1395.00.

... An inexpensive yet useful line of signal routing accessories are being marketed by KIK. A little imagination will reveal many applications for the synthesist. The A/B Footswitch routes an input signal to either one of two outputs. One may for instance change the signal routing in a patch without altering connections or settings, and without taking your hands away from the main task, playing. Retail price is \$25.00. The A/B Toggle Box is identical to the A/B Footswitch (price included) except that it is hand operated by a toggle switch. The KIK Solo Box (footswitch operated) will pass the input unaltered or can be switch to a pre-set volume level that the performer controls with a potentiometer mounted on the side of the unit. Retail is also \$25.00. Also of interest is the inexpensive 4 to 1 Mixer. At a retail price of \$35.00, it provides an excellent means of mixing your keyboards or adding input channels to an already overcrowded mixing system.

... On Friday, March 24, Boston's New England Conservatory of Music will present, under the direction of Robert Ceely, an electronic music concert. The 8 P.M. concert will feature compositions by the following of Mr. Ceely's students: Michael Botham, Rick Boulanger, Roger Bourland, Scott Martin, Christopher Stowens, and Joseph Valent. The concert is free and open to the public. For information please call (617) 731-3785 ext. 309.

... The American Society of Uni-

WHAT'S HAPPENING

Profile: Klaus Schulze

PHOTOGRAPH BY GUIDO HARARI/MILAN

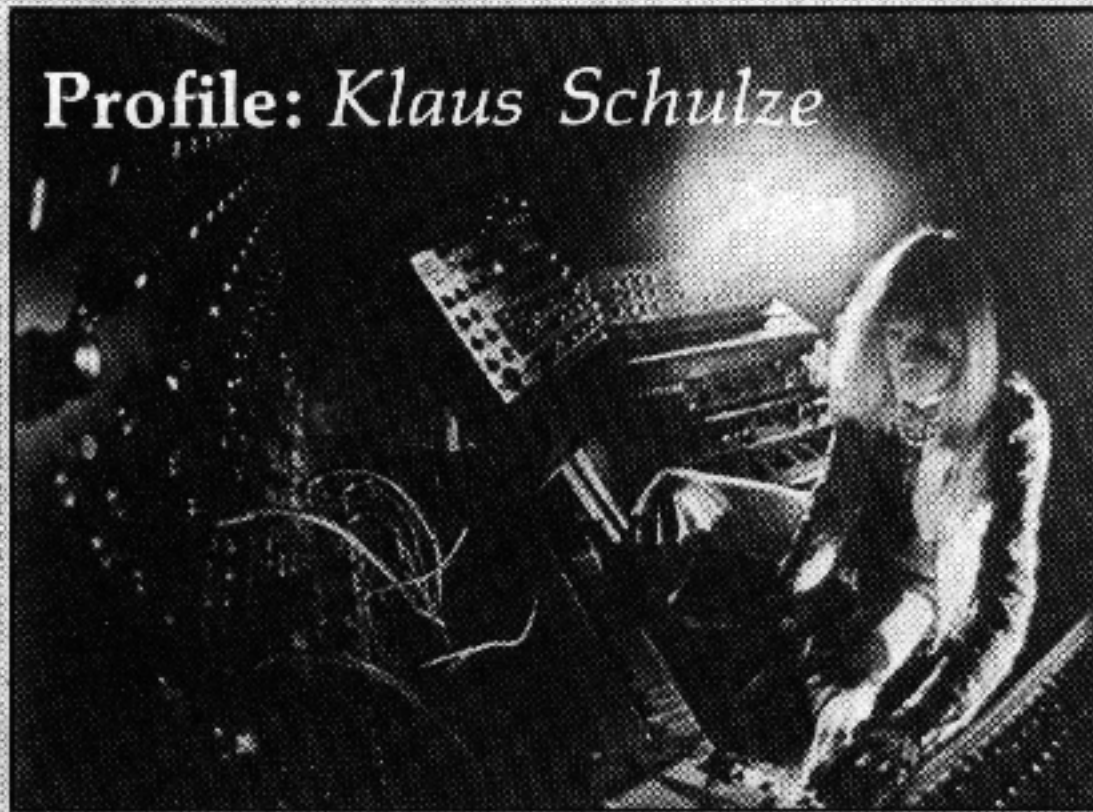

The name of Klaus Schulze is not particularly well known in this country, except perhaps among import record collectors. To date, Schulze has had eight solo recordings released, dating back to 1972, all of which give a strong indication of musical development and technical advancement. Their most impressive feature is the maturity of emotional content in the later recordings.

It is very difficult to find articles, or indeed any other information, on Schulze's background. As a result I contacted Schulze in person, and he obligingly provided many biographical details. Born in Berlin on August 4, 1947, he attended various schools between 1954 and 1968, then specializing particularly in psychology and music from 1970 to 1974. Schulze started out as a drummer with a group called "Psyfree," but his desire to find new forms of expression led to his joining "Tangerine Dream" in 1969. At that time the band consisted of Edgar Froese on guitar and organ, Konrad Schnitzler on cello, violin and flute, and Schulze on drums. Their developing, and for that time, unconventional, output can be heard on an import LP called "Electronic Meditations".

One year later Schulze left to form a new band, "Ash Ra Tempel," with Manuel Gottsching and Hartmut, whose first album will probably be known only to import collectors. On this period, Schulze states, "I tried to extend the usual guitar, bass and drums type of rock that was prevalent at that time. Slowly but surely I was getting tired of this kind of music, but looking back I can say that the time with "Ash Ra Tempel" was very productive and brought us a lot of fun. We never rehearsed, but we all grew spontaneously by musical and human harmony."

In 1971 Schulze decided to go solo, starting to develop his own Berlin studio, and giving rise to "Irrlicht," a work made with simple tape and keyboard techniques alongside an orchestra. However, by February of 1973, Schulze was back with "Ash Ra Tempel" for their first big concert, staged in Paris before a large and receptive audience: seemingly the breakthrough that Schulze had been looking for, and unable to find in Germany, where most

Continued on page 8

versity Composers will sponsor a series of discussions concerning the formation of a consortium of electronic music studios during the 1978 convention, March 22-25, at the University of Miami, Coral Gables, Florida. Interested persons are asked to submit suggestions for the content and direction of the discussions and the role that such a consortium might play in contemporary music. These discussions will be held in a spirit of communication and the

ASUC is appealing to any communities that might have an interest in electronic music. Please forward topics of concern and ideas for consideration to: Cleve L. Scott, Co-chairman, Region V, ASUC, Ball State University, Mich. 47306, (317) 285-7072.

... Dennis Electronics has released the Control Voltage Processor (CVP). The CVP is an assemblage of pre-patched voltage processing

modules that can be combined to produce many additional functions. Independent functions included are two input attenuators, full wave rectifier, two slew limiters, inverter, voltage mixer, variable offset voltage, two comparators, and a schmitt trigger. The unit can be combined to produce functions including envelope following, envelope generation, threshold switching and rhythm generation. The CVP alone is \$159.99, and with the 202 Modular Power Supply and mahogany cabinet, \$299.00.

... Polyfusion, Inc. has released the model SP-1 Sound-A-Round Stereo Panner. The unit has an automatic sweep control variable from



Polyfusion SP-1 with foot pedal.

one sweep per 10 seconds to 14 sweeps per second. The rate of the sweep can also be varied by an external control voltage. Included is a footswitch used to select between the sweeping pan and equal output levels from both channels. The unit lists for \$99.95.

... Sound Sales Inc. has announced the purchase of the Mellotron Company of London, England on November 28, 1977. Effective January 1, 1978, all manufacturing, servicing, parts, tapes and sales will be handled out of Sound Sales' Connecticut office.

... Chicago is now host to a non-college-affiliated, electronic art center, named Omega Intermedia Center. The center is staffed and operated by Michael Markowski, Peter Scheff, Frank Garvey and Pamela Sloan; all members of the multimedia group, Megaton. In addition to their performances, which include lasers, film and live electronics, the members offer workshops in electronics, multi-media and micro-computers. Planned for the near future are courses in video and holography.

... Pieces, 3 has recently been released by Michael Byron (No. 240 Fine Arts Bldg., York University, 4700 Keele Street, Downsview, Ontario MDJ 1P3 Canada) and, as in the past, dedicates itself to works of experimental music, both electronic and instrumental. Composers included, to name only a few, are Michael Byron, Philip Corner, Peter Garland, Dick Higgins and Alvin Lucier. Pieces, 3 costs \$6.00, and is available direct from the publisher.

Sequential Circuits Introduces:

the prophet

The Industry's First Completely Programmable Polyphonic Synthesizer

When Sequential Circuits introduces a synthesizer, you can be sure it utilizes the most advanced technology..... state-of-the-art technology that makes readily available the most asked for features musicians have been demanding for years.



the prophet

comes in 5 and 10 voice versions, 2 oscillators per voice. Individual oscillator tuning? We think you have better things to do with your time. The Prophet's powerful internal computer automatically handles all tuning. The same computer lets you create and record 40 different patches and recall any at the simple touch of a button.

More? A 5-octave keyboard. Pitch and Modulation wheels. Small size (37" x 16" x 4½"), ideal for stacking with other keyboards. Memory power back up with a 10 year life.

The Prophet provides unparalleled ease of use while retaining the sophistication required by the most demanding synthesists.

Prove it to yourself. Ask your local dealer or write us for further information.

SEQUENTIAL CIRCUITS INC

1172G Aster Avenue, Sunnyvale, Calif. 94086 (408) 296-3116

THE CAT "SRM" SYNTHESIZER



NOW WITH 2 NOTE MEMORY.

There are many synthesizers with 2 voice capability, but the CAT "SRM" has a unique 2 note memory system. What is the difference between 2 voice capability and 2 note memory? Well, if you've tried certain 2 note synthesizers, you know how frustrating it can be when you let go of the two notes and both oscillators jump to the last note released. Not the CAT "SRM".

Our keyboard circuitry incorporates a special 2 note memory system which memorizes both the highest and lowest notes depressed to let you sustain intervals even after lifting your hand off of the keyboard. Now you can play the cleanest 2 note polyphonic lines you'll ever need.

LFO delay is also available on the "SRM" this means you can get delayed vibratos, delayed filter sweeps and a delayed pulse width modulation - without touching

the panel during a performance. An LFO monitor lets you see the LFO speed with a solid state lamp that flashes at the LFO frequency setting. All waveshapes on both VCO 1 and VCO 2 has its own volume control affording you complex timbres and various modulation effects. These mixable waveshapes offer you STUDIO VERSATILITY in a compact synthesizer.

Only by mixing waveshapes can we offer you our 4 note sequencer patch, where you can actually get 4 sequenced notes whose frequency spacing, rhythm and tempo can all be varied. All these features and more make the CAT "SRM" one of the most versatile synthesizers in its class and for HUNDREDS of dollars less than many other 2 oscillator synthesizers. For a complete demonstration contact an Octave dealer or write to us for a complete catalog. Octave Electronics, 32-73 Steinway St., L.I.C., New York 11103, (212) 278-7422.

THE CAT "SRM"
WHERE QUALITY IS OUR MOST IMPORTANT FEATURE.

OCTAVE Electronics Inc.

Division of Syn-Cordion Musical Instrument Corp.
32-73 STEINWAY STREET, LONG ISLAND CITY, N. Y. 11103

THIRD CLASS MAIL

BULK RATE
U. S. POSTAGE
PAID
No. Hollywood, CA
PERMIT NO. 456